

CONTENTS

AluminTechno JLLC	
System description	01
Order information	02
Accessories	03
Equipment	04
Table of glazing	05
Sections and junctions	06
Calculation examples	07
Profile machining and assemblage	08
Hardware installation	09
Statics	10

 AluminTechno JLLC



AluminTechno JLLC is an aluminium extrusions manufacturing enterprise with powder coating and anodizing lines and is a part of ALUTECH Group of Companies. The manufacturing area is 40 000 m².

AluminTechno JLLC total manufacturing capacities, tons per year:

extrusion lines	more than 45 000
coating lines	more than 35 000
anodizing shops	more than 10 000
foundry shop	up to 75 000

MANUFACTURING

Our high-performance modern enterprise is equipped with machinery produced by the leading manufacturers from the USA, Germany and Italy. Production process and manufacturing equipment have no analogs within European countries. The complete production cycle is being performed at AluminTechno plants: from primary aluminium foundry casting works to production of aluminium profiles and their further coating. The main manufacturing components are modern foundry complexes, high-performance extrusion lines, advanced coating and anodizing manufacturing shops:

- **New foundry shop**, which consists of two gas melting furnaces 35 tons each, casting device for aluminium billets casting, hydraulic casting machine, automatic end cutting and marking line, automatic billets stacker/destacker, two homogenizing furnaces and cooling chamber.



- **6 modern high-performance extrusion line**—two lines of 5" diameter, three of 7" and one of 9"—ensuring high pressing speed, stable profiles geometry and mechanical properties.

- **Two vertical powder coating lines**—advanced coating equipment with the use of chrome-free technology, a system of quick color change (within 10–15 min), automatic temperature adjustment and polymerization process control. High-technology equipment ensures quality and even surface coating with high corrosion, thermal and UV resistance.

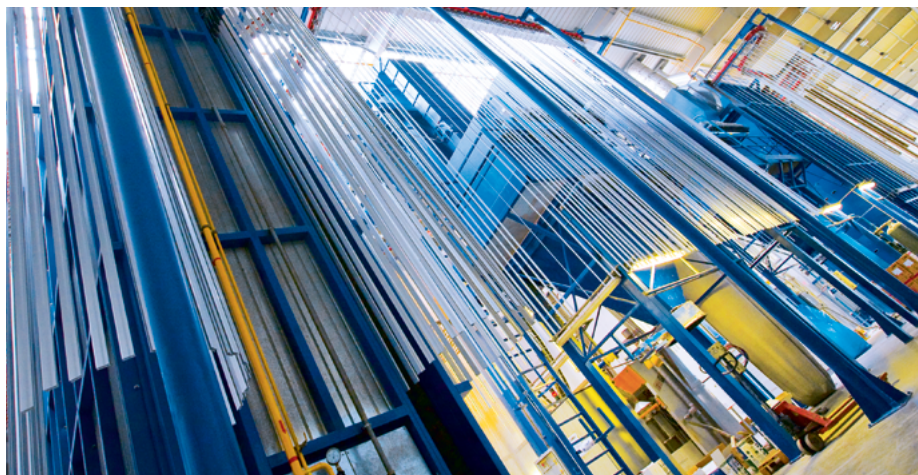

- The largest in Eastern Europe **aluminium anodizing complex** (two anodizing lines). Manufacturing capacity—10 000 tons of profiles per year. 9 colors and 4 surface treatment types available. The facilities allow to treat profiles up to 7.2 m long. Additional technologies of surface mechanical treatment are applied to create various decorative effects: brushing, bead-blasting, polishing.

PRODUCTS

Currently AluminTechno JLLC produces a wide range of aluminium extrusions (more than 1000 different configurations) used in construction, motor production, furniture and consumer goods, automotive industries, electric-power industry. Own engineering developments implementation allows us to produce and commercialize more than 20 product lines.

AluminTechno JLLC has certified its quality control management system in accordance with the requirements of International Standard ISO 9001:2008. Certificate № 75.100.70118.

AluminTechno JLLC products are certified according to national standards of EU countries, USA, Russia, Ukraine and Belarus. The extrusion quality meets the requirements of DIN17615, EN 755-1, EN 755-2, EN 12020 standards.

Finish quality of aluminium extrusion produced by AluminTechno JLLC is proved by three international certificates:

- **QUALICOAT**—international quality label of powder coatings used in architectural building systems.
- **SEASIDE** (addition to Qualicoat certificate)—international quality label confirming the resistance of aluminium profiles coating in aggressive seaside areas.
- **Qualanod**—international quality label for anodic coating of aluminium profiles, used in architectural building systems.



The use of newest technologies and modern automated equipment allows to manufacture in a short time frame the products meeting the European quality standards, including the production of extruded profiles on the basis of customers' drawings.

 ALUTECH ALT SL160

**ALUTECH ALT SL160**

Lifting and sliding
constructions

01

02

03

04

05

06

07

08

09

10

SYSTEM DESCRIPTION

ALT SL160 system is designed for the manufacturing of thermally insulated lift and slide doors with one or several active sashes as well as fixed ones.



The system provides vast opportunities for architects and designers for large wall openings glazing. The glass structure will become the main accent and decoration of the premise. Moreover, the facade of the house with panoramic windows always look spectacularly and modern.

Thermal windows and doors can replace a wall. They have a high level of burglar protection and improve the illumination of residential premises. In open position the sash does not occupy the room space.

Thanks to the developed sealing system and inserts made of foamed material, the ALT SL160 structures reliably protect the premises from bad weather conditions such as intense cold or strong wind.

Main characteristics of SL160 system

Soundproofing* EN ISO 140-3	up to 43 dB
Thermal insulation* EN ISO 10077-2	$U_w \leq 1,1 \text{ W/m}^2\text{K}$
Air permeability EN 12207	Class 4
Water permeability EN 12208	E900
Security (burglar resistance)	
PAS24:2016	Pass
ENV 1627	WK2
Hardware is designed for maximal sash weight (with additional bogies)	330 kg (440 kg)

Technical data

Fame mounting depth	160 mm
Sash mounting depth	72 mm
Maximal glazing thickness	54 mm
Maximal sash weight	440 kg
Maximal sash height	3385 mm
Maximal sash width	3235 mm

* Depending on the type of infill unit selected.

Advantages of the SL160 system

1 Modern design and functionality

2 Maximum illumination and dimensions of the doors provide additional space in premises

The height of the doors can reach 3385 mm, the maximum width—3235 mm. The width of structures using connecting elements is increased to 19500 mm.

3 High thermal characteristics of the system

Thanks to the use of wide polyamide thermal breaks, as well as the possibility of installing double-glazed infill units up to 54 mm thick, the thermal characteristics of the doors significantly increase.

4 'Anti Bi-Metal' polyamide thermal breaks

The use of 'Anti Bi-Metal' polyamide thermal breaks with the width of 32 mm in sash profiles makes possible to compensate temperature differences on the inner and outer 'chambers' of the combined profile.

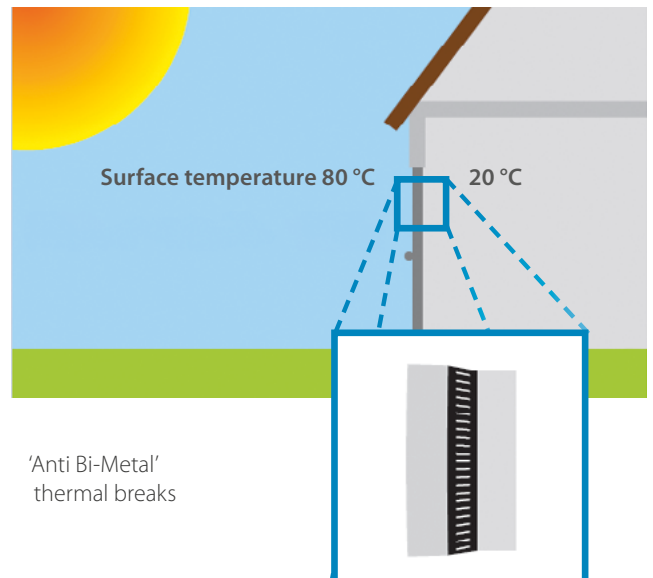
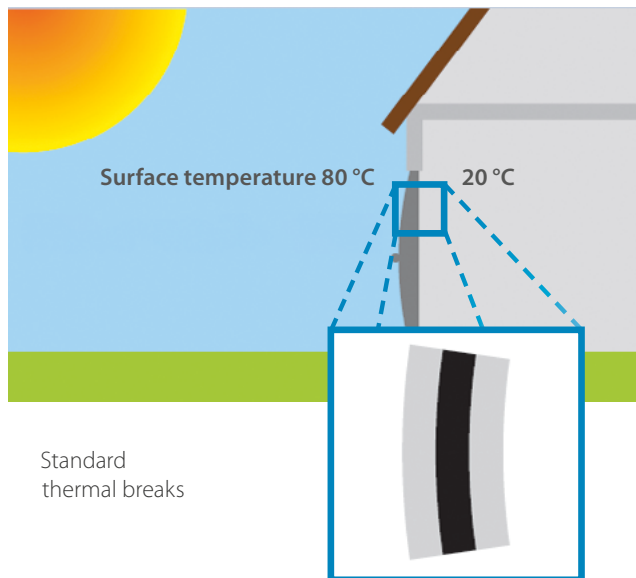
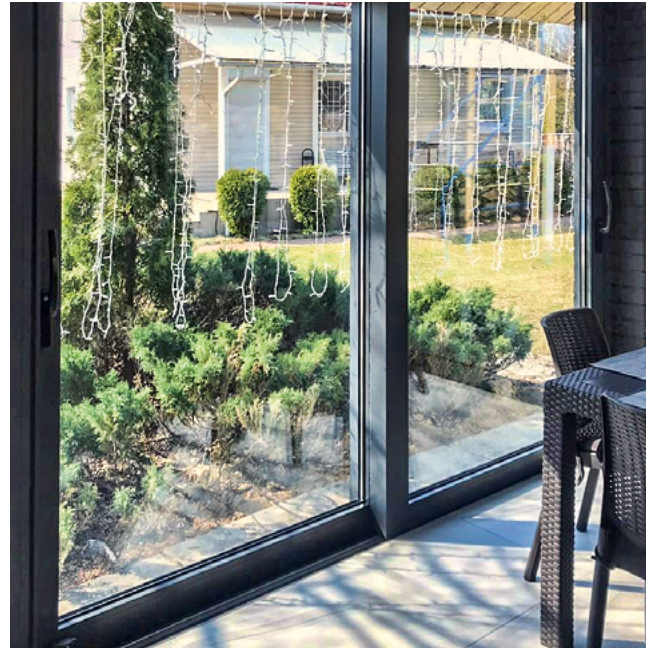

5 Compatibility with ALT W62/72 window and door systems and ALT F50 facade series

The system has developed adapter profiles that allow you to create easy-to-install and aesthetic integration of SL160 system in F50 curtain walls. It can be possible as well to integrate this system with the windows and doors from W62/72 series. Due to the fact that the mounting depth of the SL160 sash profiles coincides with the W72 profiles, the unique style of the external and internal appearance of projects is preserved.

6 Security

The system provides for the installation of anti-burglar elements and the possibility of using anti-burglar hardware. ALT SL160 system meets the requirements of class PAS 24 (UK certificate).

Pictograms

Attention	Technical information	Can be replaced	See page	Turned view	Turn	Turn	Perform the indicated operation	
Pneumatic punching machine	Jig	Sash weight	Performance improvement	Silicone sealant	2-component polyurethane glue	Glue for EPDM		
<p>1.</p> <p>1.1.</p> <p>2.</p> <p>Пометание</p>								
	Hold time	Hold 15 min	Hold 30 min	Hold 45 min				
	Measure	Measure	Measure	Clean the surface	Apply glue	Apply sealant		
Mark out	Cut	Nip	Cut with knife	Push on	Strike			
Tighten	Joint	Detach	Use a key	Clamping	Drift pin	Crimping	Flatness	
Screw in	Drill	Mill	Фрезеровать	Countersink	Use trowel	Roller for gasket installation	Delete	

01

02

03

04

05

06

07

08

09

10

ALT SL160 Lift and slide door

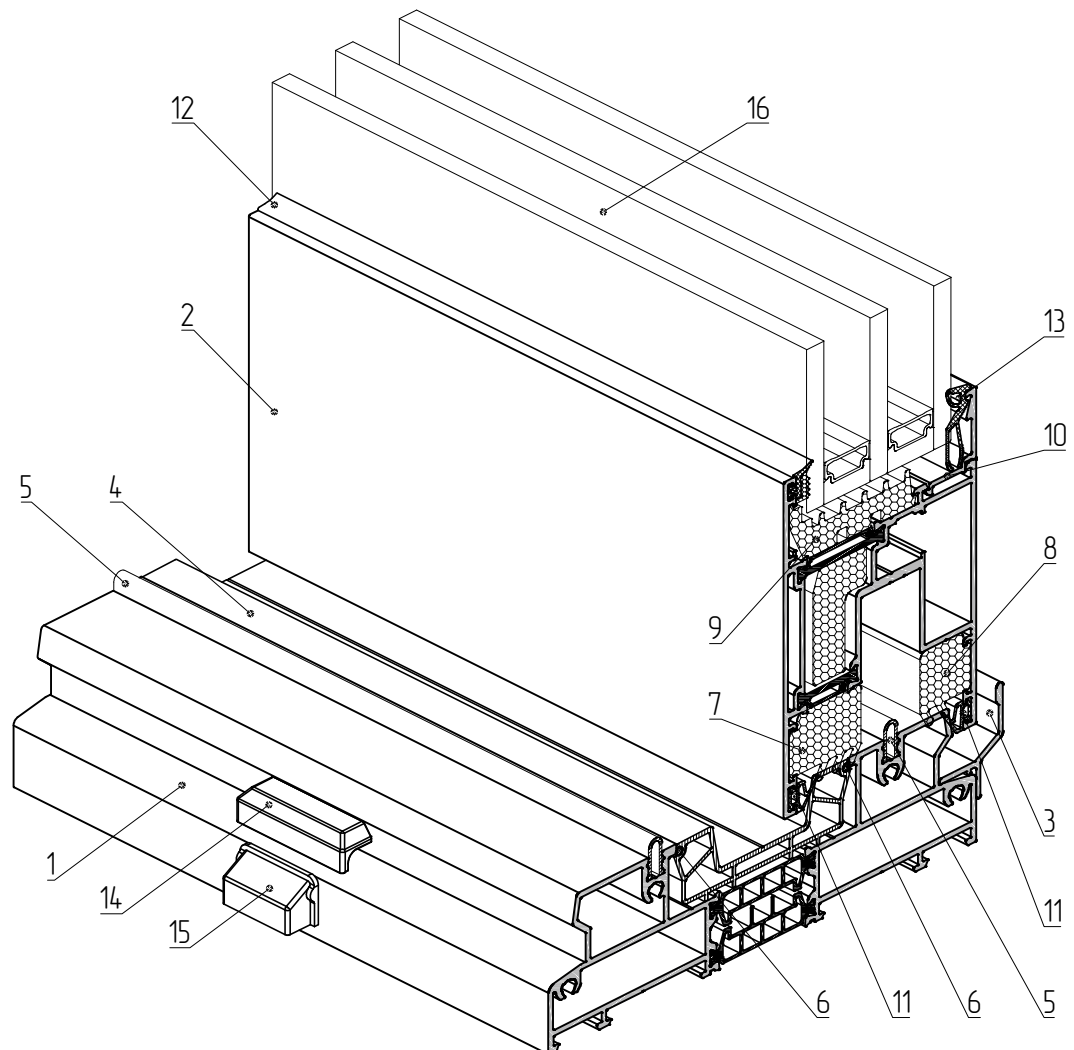

- 1 - AYPC.SL160.0101 frame profile
- 2 - AYPC.SL160.0202 sash profile
- 3 - AYPC.SL160.0805 drain profile
- 4 - AYPC.SL160.0920 drain profile
- 5 - AYPC.SL160.1950 stainless steel track
- 6 - AYPC.SL160.0948 foamed EPDM gasket
- 7 - AYPC.SL160.0960 thermal insert
- 8 - AYPC.SL160.0961 thermal insert
- 9 - AYPC.W72.0911 rebate insulation
- 10 - AYPC.C48.0601 glass bead profile
- 11 - FRK175 rebate gasket
- 12 - FRK197 outside gasket
- 13 - FRK193 wedge gasket
- 14 - AYPC.SL160.0929 water drain plug
- 15 - AYPC.C48.0919-01 drain plug
- 16 - 54 mm infill unit

ALT SL160 Lift and slide door

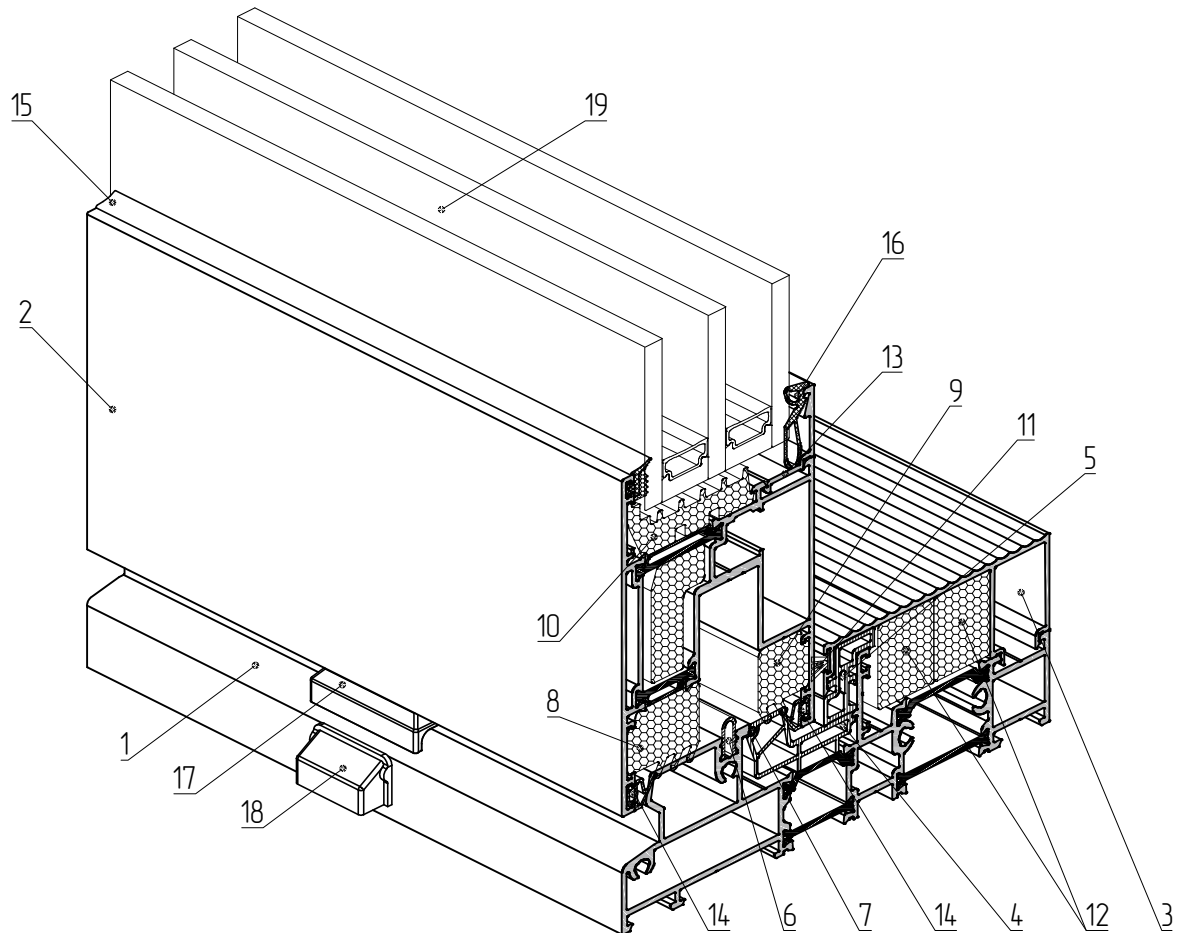

- 1 – AYPC.SL160.0102 frame profile. Single track
- 2 – AYPC.SL160.0202 sash profile
- 3 – AYPC.SL160.0806 threshold profile
- 4 – AYPC.SL160.0923 drain profile
- 5 – AYPC.SL160.0924 added profile
- 6 – AYPC.SL160.1950 stainless steel track
- 7 – AYPC.SL160.0948 foamed EPDM gasket
- 8 – AYPC.SL160.0960 thermal insert
- 9 – AYPC.SL160.0961 thermal insert
- 10 – AYPC.W72.0911 rebate insulation
- 11 – ISE01 felt sealing
- 12 – AYPC.SL160.0918 foamed insert
- 13 – AYPC.C48.0601 glass bead profile
- 14 – FRK175 rebate gasket
- 15 – FRK197 outside gasket
- 16 – FRK193 wedge gasket
- 17 – AYPC.SL160.0929 water drain plug
- 18 – AYPC.C48.0919M-01 water drain plug
- 19 – 54 mm infill unit

ALT SL160 Lift and slide door

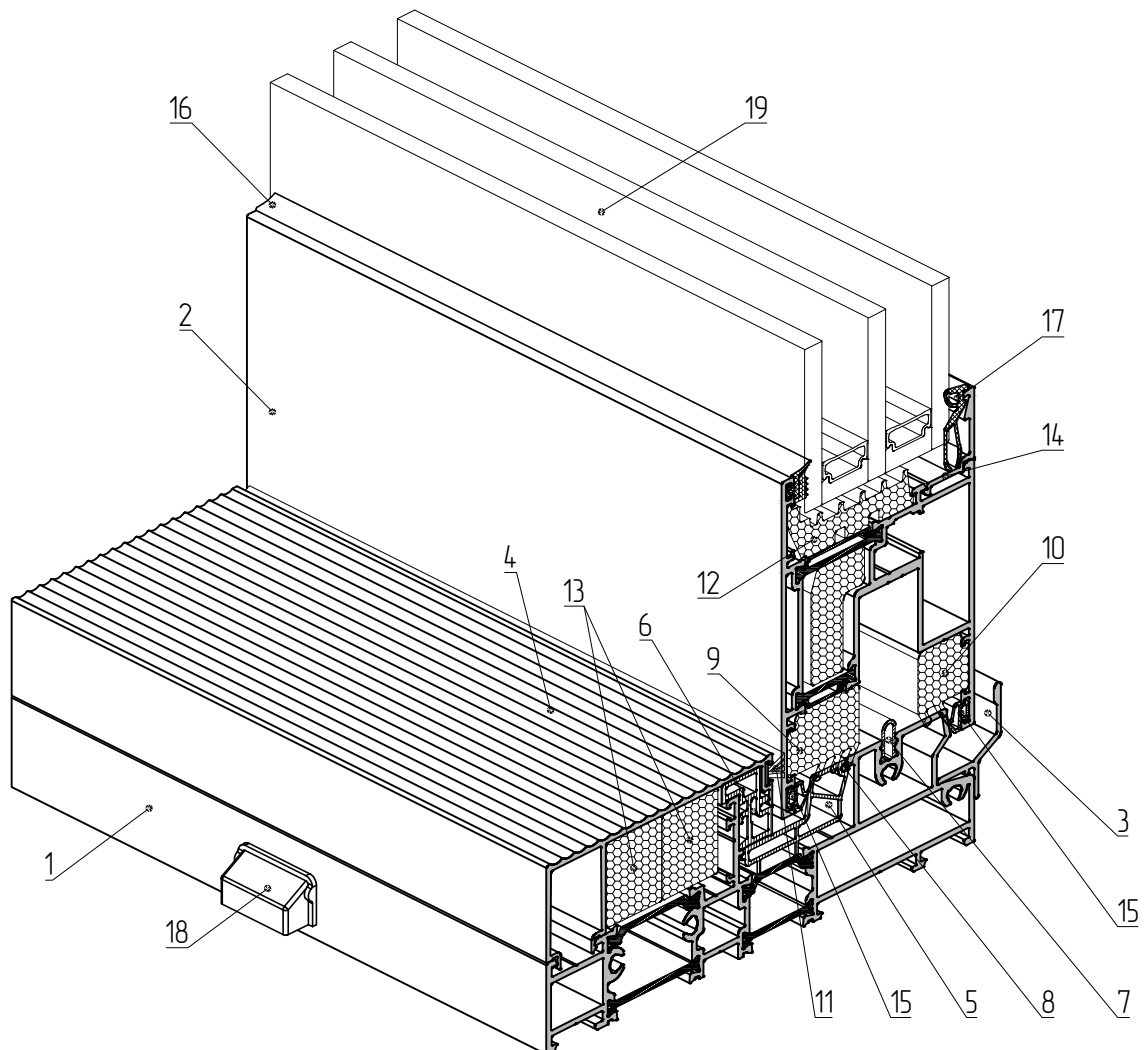

- 1 – AYPC.SL160.0103 frame profile
- 2 – AYPC.SL160.0202 sash profile
- 3 – AYPC.SL160.0805 drain profile
- 4 – AYPC.SL160.0806 threshold profile
- 5 – AYPC.SL160.0923 drain profile
- 6 – AYPC.SL160.0924 added profile
- 7 – AYPC.SL160.1950 stainless steel track
- 8 – AYPC.SL160.0948 foamed EPDM gasket
- 9 – AYPC.SL160.0960 thermal insert
- 10 – AYPC.SL160.0961 thermal insert
- 11 – ISE01 felt sealing
- 12 – AYPC.W72.0911 rebate insulation
- 13 – AYPC.SL160.0918 foamed insert
- 14 – AYPC.C48.0601 glass bead profile
- 15 – FRK175 rebate gasket
- 16 – FRK197 outside gasket
- 17 – FRK193 wedge gasket
- 18 – AYPC.C48.0919M-01 water drain plug
- 19 – 54 mm infill unit



SL160 system with AYPC.SL160.0103 frame profile is recommended to use in weatherproof premises as well as in the protected areas.

ALT SL160 Lift and slide door

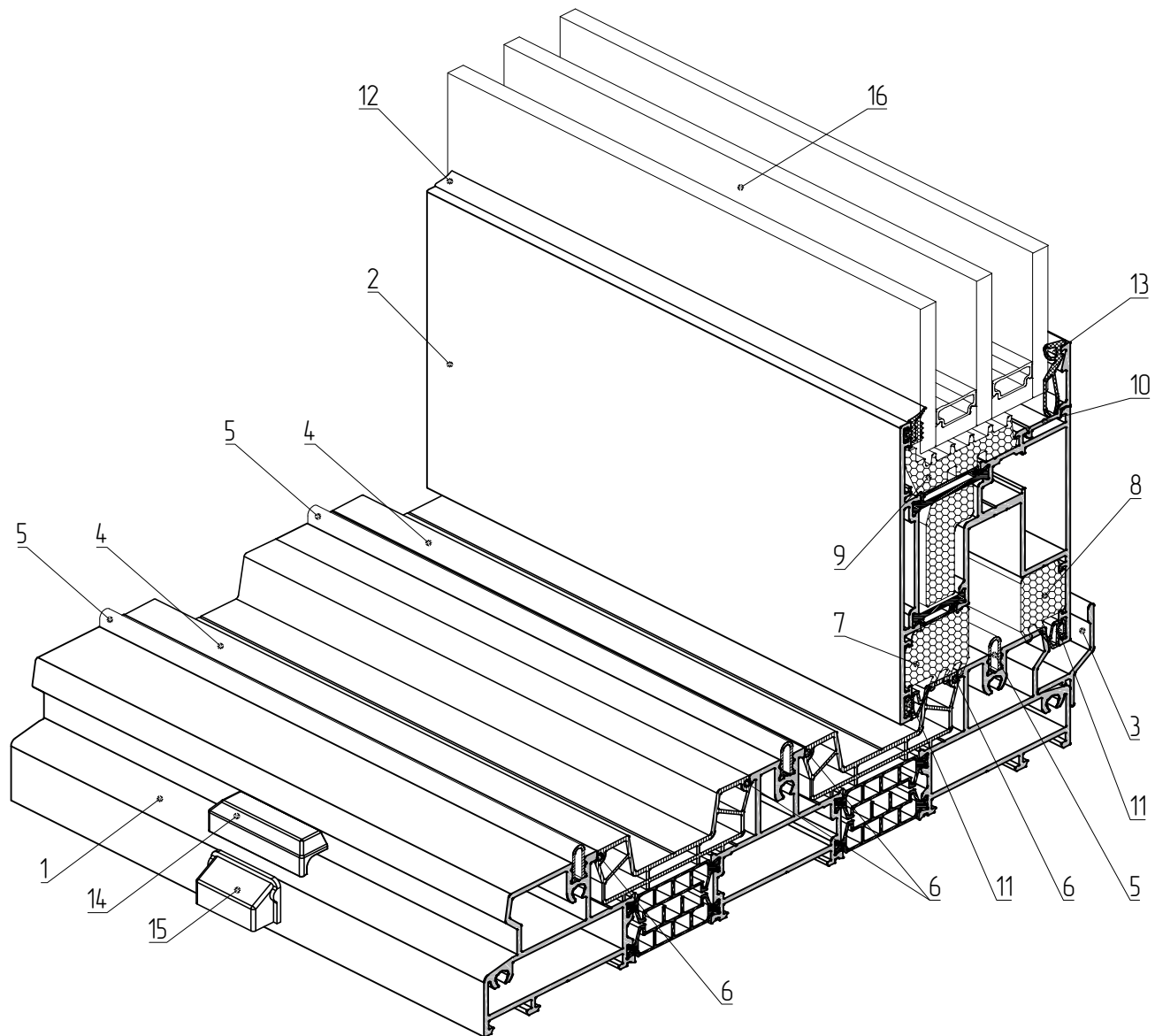

- 1 – AYPC.SL160.0104 frame profile
- 2 – AYPC.SL160.0202 sash profile
- 3 – AYPC.SL160.0805 drain profile
- 4 – AYPC.SL160.0920 drain profile
- 5 – AYPC.SL160.1950 stainless steel track
- 6 – AYPC.SL160.0948 foamed EPDM gasket
- 7 – AYPC.SL160.0960 thermal insert
- 8 – AYPC.SL160.0961 thermal insert
- 9 – AYPC.W72.0911 rebate insulation
- 10 – AYPC.C48.0601 glass bead profile
- 11 – FRK175 rebate gasket
- 12 – FRK197 outside gasket
- 13 – FRK193 wedge gasket
- 14 – AYPC.SL160.0929 water drain plug
- 15 – AYPC.C48.0919-01 drain plug
- 16 – 54 mm infill unit



ALUTECH ALT SL160

Lifting and sliding constructions

ORDER INFORMATION

Article	Name Drawing	Weight, kg/m	Exterior perimeter, mm	Cross sectional area, mm ²	Code	Profile colour	Bar length, m	Quantity in pack		Weight of a pack	
								pcs	m	net, kg	gross, kg
AYPC.SL160.0101	Frame profile: Double track 	3.34	573	1347.3	12600100	00	6.5	1	6.5	21.7	22.3
					12600121	RAL9016				22.2	22.8
					12600124	RAL8014				22.2	22.8
					12600130	RAL8017				22.2	22.8
					12600131	RAL9006				22.2	22.8
					126001808	A00-D6				21.7	22.3
AYPC.SL160.0102	Frame profile: Single track 	3.27	625	1336.6	12600800	00	6.5	1	6.5	21.3	21.9
					12600821	RAL9016				21.8	22.4
					12600824	RAL8014				21.8	22.4
					12600830	RAL8017				21.8	22.4
					12600831	RAL9006				21.8	22.4
					126008808	A00-D6				21.3	21.9
AYPC.SL160.0103	Frame profile: Single track 	3.32	625	1355.2	12600900	00	6.5	1	6.5	21.6	22.2
					12600921	RAL9016				22.1	22.7
					12600924	RAL8014				22.1	22.7
					12600930	RAL8017				22.1	22.7
					12600931	RAL9006				22.1	22.7
					126009808	A00-D6				21.6	22.2
AYPC.SL160.0104	Frame profile: Triple track 	4.68	868	1952.5	12602600	00	6.5	1	6.5	30.4	31.1
					12602621	RAL9016				31.1	31.8
					12602624	RAL8014				31.1	31.8
					12602630	RAL8017				31.1	31.8
					12602631	RAL9006				31.1	31.8
					126026808	A00-D6				30.4	31.1
AYPC.SL160.0202	Sash profile (Anti bi-metal) 	2.50	591	1003.6	12602321	RAL9016	6.5	2	13.0	33.5	34.0
					12602324	RAL8014				33.5	34.0
					12602330	RAL8017				33.5	34.0
					12602331	RAL9006				33.5	34.0
					126023808	A00-D6				32.5	33.0
AYPC.SL160.0202N	Sash profile (Anti bi-metal) 	2.49	591	1003.6	12602400	00	6.5	2	13.0	32.4	32.9
					12602421	RAL9016				33.4	33.9
					12602424	RAL8014				33.4	33.9
					12602430	RAL8017				33.4	33.9
					12602431	RAL9006				33.4	33.9
					126024808	A00-D6				32.4	32.9

01

02

03

04

05

06

07

08

09

10

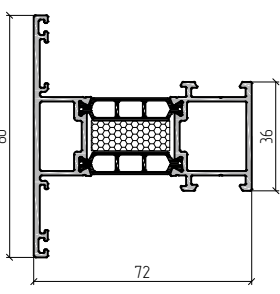
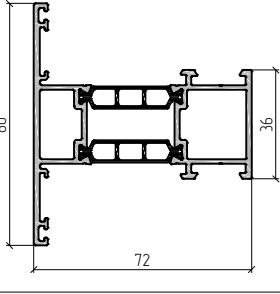
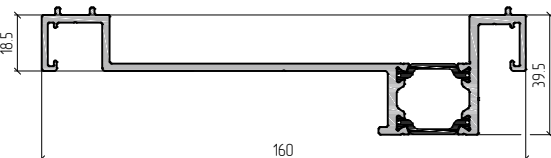
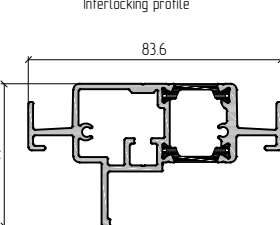
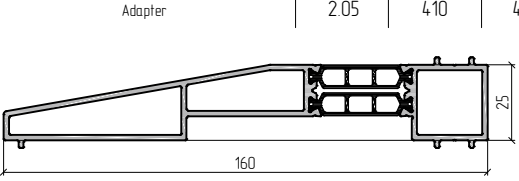
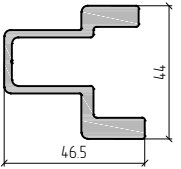
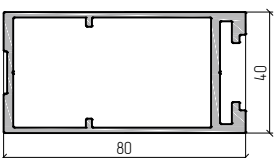
Article	Name Drawing	Weight, kg/m	Exterior perimeter, mm	Cross sectional area, mm ²	Code	Profile colour	Bar length, m	Quantity in pack		Weight of a pack	
								pcs	m	net, kg	gross, kg
AYPC.SL160.0301	Transom profile 	166	408	703.5	12603121	RAL9016 RAL8014 RAL8017 RAL9006 A00-D6	6.5	2	13.0	22.3	22.9
					12603124					22.3	22.9
					12603130					22.3	22.9
					12603131					22.3	22.9
					126031808					21.6	22.2
AYPC.SL160.0301N	Transom profile 	166	408	703.5	12603200	00 RAL9016 RAL8014 RAL8017 RAL9006 A00-D6	6.5	2	13.0	21.6	22.2
					12603221					22.3	22.9
					12603224					22.3	22.9
					12603230					22.3	22.9
					12603231					22.3	22.9
126032808	21.6	22.2									
AYPC.SL160.0501	Adapter for curtain walling 	2.08	550	827.0	12603700	00 RAL9016 RAL8014 RAL8017 RAL9006 A00-D6	6.5	2	13.0	27.1	27.7
					12603721					28.0	28.6
					12603724					28.0	28.6
					12603730					28.0	28.6
					12603731					28.0	28.6
126037808	27.1	27.7									
AYPC.SL160.0504	Interlocking profile 	159	352	639.2	12602500	00 RAL9016 RAL8014 RAL8017 RAL9006 A00-D6	6.5	2	13.0	20.7	21.5
					12602521					21.5	22.5
					12602524					21.5	22.5
					12602530					21.5	22.5
					12602531					21.5	22.5
126025808	20.7	21.5									
AYPC.SL160.0505	Adapter 	2.05	410	46.2	12603800	00 RAL9016 RAL8014 RAL8017 RAL9006 A00-D6	6.5	2	13.0	26.7	27.3
					12603821					27.5	28.1
					12603824					27.5	28.1
					12603830					27.5	28.1
					12603831					27.5	28.1
126038808	26.7	27.3									
AYPC.SL160.0701	Reinforcing profile 	1.35	256	500.9	12601900	00	6.5	2	13.0	17.6	18.5
AYPC.SL160.0702	Reinforcing profile 	1.57	500	583.0	12602000	00 RAL9016 RAL8014 RAL8017 RAL9006 A00-D6	6.5	2	13.0	20.5	20.9
12602021	21.3	21.7									
12602024	21.3	21.7									
12602030	21.3	21.7									
12602031	21.3	21.7									
126020808	20.5	20.9									

Article	Name Drawing	Weight, kg/m	Exterior perimeter, mm	Cross sectional area, mm ²	Code	Profile colour	Bar length, m	Quantity in pack		Weight of a pack	
								pcs	m	net, kg	gross, kg
AYPC.SL160.0801		0.50	137	184.1	12600400	00	6.5	4	26.0	13.0	13.6
					12600421	RAL9016				13.4	14.0
					12600424	RAL8014				13.4	14.0
					12600430	RAL8017				13.4	14.0
					12600431	RAL9006				13.4	14.0
					126004808	A00-D6				13.0	13.6
AYPC.SL160.0802		0.45	227	166.5	12600500	00	6.5	4	26.0	11.7	12.0
					12600521	RAL9016				12.4	12.7
					12600524	RAL8014				12.4	12.7
					12600530	RAL8017				12.4	12.7
					12600531	RAL9006				12.4	12.7
					126005808	A00-D6				11.7	12.0
AYPC.SL160.0804		0.30	130	111.0	12601100	00	6.5	4	26.0	7.8	7.9
					12601121	RAL9016				8.0	8.1
					12601124	RAL8014				8.0	8.1
					12601130	RAL8017				8.0	8.1
					12601131	RAL9006				8.0	8.1
					126011808	A00-D6				7.8	7.9
AYPC.SL160.0805		0.23	97	87.0	12601200	00	6.5	4	26.0	6.1	6.2
					12601221	RAL9016				6.3	6.3
					12601224	RAL8014				6.3	6.3
					12601230	RAL8017				6.3	6.3
					12601231	RAL9006				6.3	6.3
					126012808	A00-D6				6.1	6.2
AYPC.SL160.0806		0.76	352	281.2	12601300	00	6.5	2	13.0	9.9	10.0
					12601321	RAL9016				10.1	10.9
					12601324	RAL8014				10.1	10.9
					12601330	RAL8017				10.1	10.9
					12601331	RAL9006				10.1	10.9
					126013808	A00-D6				9.9	10.0
AYPC.SL160.0807		0.54	282	201.5	12601400	00	6.5	2	13.0	7.1	7.1
					12601421	RAL9016				7.2	7.3
					12601424	RAL8014				7.2	7.3
					12601430	RAL8017				7.2	7.3
					12601431	RAL9006				7.2	7.3
					126014808	A00-D6				7.1	7.1
AYPC.SL160.0808		0.91	415	337.3	12603500	00	6.5	2	13.0	11.8	12.2
					12603521	RAL9016				12.5	12.9
					12603524	RAL8014				12.5	12.9
					12603530	RAL8017				12.5	12.9
					12603531	RAL9006				12.5	12.9
					126035808	A00-D6				11.8	12.2
AYPC.SL160.0810		0.63	278	231.6	12602100	00	6.5	2	13.0	16.3	16.7
					12602121	RAL9016				16.7	17.2
					12602124	RAL8014				16.7	17.2
					12602130	RAL8017				16.7	17.2
					12602131	RAL9006				16.7	17.2
					126021808	A00-D6				16.3	16.7
AYPC.SL160.0811		0.63	278	231.6	12602200	00	6.5	2	13.0	16.3	16.7
					12602221	RAL9016				16.7	17.2
					12602224	RAL8014				16.7	17.2
					12602230	RAL8017				16.7	17.2
					12602231	RAL9006				16.7	17.2
					126022808	A00-D6				16.3	16.7
AYPC.SL160.0812		0.38	108	142.0	12602700	00	6.5	4	26.0	9.9	10.6
					126027429	RAL9005 I 30				10.3	11.0
AYPC.SL160.0813		1.80	385	668.1	12603600	00	6.5	2	13.0	23.4	23.8
					12603621	RAL9016				24.0	24.4
					12603624	RAL8014				24.0	24.4
					12603630	RAL8017				24.0	24.4
					12603631	RAL9006				24.0	24.4
					126036808	A00-D6				23.4	23.8

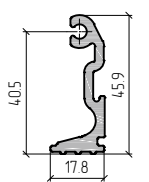
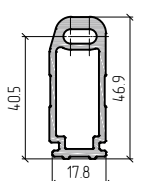
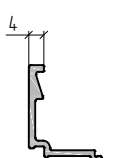
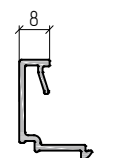
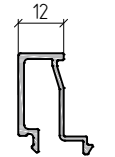
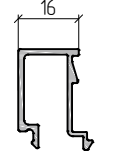
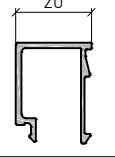
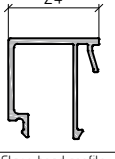
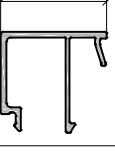
Article	Name Drawing	Weight, kg/m	Exterior perimeter, mm	Cross sectional area, mm ²	Code	Profile colour	Bar length, m	Quantity in pack		Weight of a pack	
								pcs	m	net, kg	gross, kg
AYPC.W62.0701	Transom bar fastening profile 	0.69	161	253.8	10801000	00	3.25	12	39.0	26.8	27.1
AYPC.W62.0705	Transom bar fastening profile 	0.85	133	316	10867800	00	3.25	6	19.5	16.6	16.9
AYPC.C48.0601	Glass bead profile 	0.22	95	82.1	10408100 10408121 10408124 10408130 10408131 104081808	00 RAL9016 RAL8014 RAL8017 RAL9006 A00-D6	6.5	18	117.0	25.9 29.2 29.2 29.2 29.2 25.9	26.4 29.7 29.7 29.7 29.7 26.4
AYPC.C48.0602	Glass bead profile 	0.23	117	85.1	10405800 10405821 10405824 10405830 10405831 104058808	00 RAL9016 RAL8014 RAL8017 RAL9006 A00-D6	6.5	18	117.0	26.9 30.2 30.2 30.2 30.2 26.9	27.4 30.7 30.7 30.7 30.7 27.4
AYPC.C48.0603	Glass bead profile 	0.25	145	93.3	10401700 10401721 10401724 10401730 10401731 104017808	00 RAL9016 RAL8014 RAL8017 RAL9006 A00-D6	6.5	18	117.0	29.4 31.3 31.3 31.3 31.3 29.4	29.9 31.8 31.8 31.8 31.8 29.9
AYPC.C48.0604	Glass bead profile 	0.28	150	103.1	10401800 10401821 10401824 10401830 10401831 104018808	00 RAL9016 RAL8014 RAL8017 RAL9006 A00-D6	6.5	18	117.0	32.5 34.4 34.4 34.4 34.4 32.5	33.2 35.1 35.1 35.1 35.1 33.2
AYPC.C48.0605	Glass bead profile 	0.28	151	103.4	10401900 10401921 10401924 10401930 10401931 104019808	00 RAL9016 RAL8014 RAL8017 RAL9006 A00-D6	6.5	18	117.0	32.6 34.2 34.2 34.2 34.2 32.6	33.3 34.9 34.9 34.9 34.9 33.3
AYPC.C48.0606	Glass bead profile 	0.31	172	113.4	10405400 10405421 10405424 10405430 10405431 104054808	00 RAL9016 RAL8014 RAL8017 RAL9006 A00-D6	6.5	18	117.0	35.9 37.8 37.8 37.8 37.8 35.9	36.7 38.1 38.1 38.1 38.1 36.7
AYPC.C48.0607	Glass bead profile 	0.32	180	119.4	10402000 10402021 10402024 10402030 10402031 104020808	00 RAL9016 RAL8014 RAL8017 RAL9006 A00-D6	6.5	18	117.0	37.7 39.9 39.9 39.9 39.9 37.9	38.4 40.6 40.6 40.6 40.6 38.4

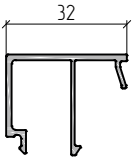
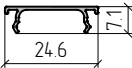
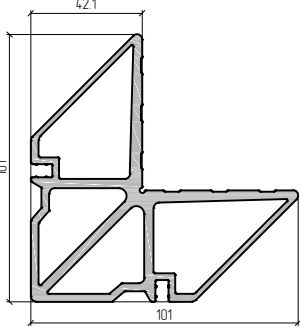
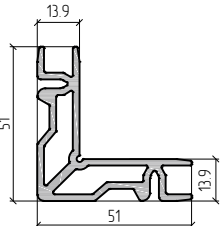
Article	Name Drawing	Weight, kg/m	Exterior perimeter, mm	Cross sectional area, mm ²	Code	Profile colour	Bar length, m	Quantity in pack		Weight of a pack	
								pcs	m	net, kg	gross, kg
AYPC.C48.0608	Glass bead profile 	0.34	188	125.4	10402100 10402121 10402124 10402130 10402131 104021808	00 RAL9016 RAL8014 RAL8017 RAL9006 A00-D6	6.5	18	117.0	39.7 41.9 41.9 41.9 39.7	40.4 42.6 42.6 42.6 40.4
AYPC.111.0605	Cover cap profile 	0.09	79	33.0	10503000 10503021 10503024 10503030 10503069 105030808	00 RAL9016 RAL8014 RAL8017 RAL9006 A00-D6	6.2	4	24.8	2.2 2.4 2.4 2.4 2.4 2.2	2.4 2.6 2.6 2.6 2.6 2.4
AYPC.C48.0705	Profile for corner cleat 	4.09	400	1514.9	10403900	00	3.25	2	6.5	26.6	26.6
AYPC.GS106.0701	Profile for corner cleat 	1.55	308	576.4	12200700	00	3.25	2	6.5	10.1	10.3



ALUTECH ALT SL160

Lifting and sliding constructions

01

02

03

04

05

06









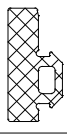

07

08

09

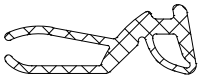
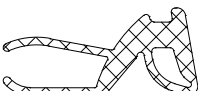
10

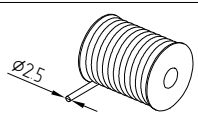
ACCESSORIES

Image	Code	Article	Weight, kg/m	Application
	10415500	FRK38	0.092	EPDM wedge gasket. Qty in pack – 400 m
	11315800	FRK50	0.049	EPDM gasket. Qty in pack – 300 m
	12420100	FRK93	0.047	EPDM outside gasket. Qty in pack – 350 m
	11316700	FRK128	0.086	EPDM gasket. Qty in pack – 120 m
	12620100	FRK175	0.018	EPDM rebate gasket. Qty in pack – 300 m
	12620200	FRK176	0.017	EPDM gasket. Qty in pack – 150 m
	12620300	FRK188	0.037	EPDM gasket. Qty in pack – 350 m
	10830300	FRK191	0.067	EPDM wedge gasket. Qty in pack – 200 m
	10830500	FRK192	0.097	EPDM wedge gasket. Qty in pack – 200 m
	10830700	FRK193	0.105	EPDM wedge gasket. Qty in pack – 200 m
	10831200	FRK194	0.135	EPDM wedge gasket. Qty in pack – 200 m
	10831400	FRK197	0.066	EPDM outside gasket. Qty in pack – 400 m
	12620500	AYPC.SL160.0948	0.006	Foamed EPDM gasket. Qty in pack – 100 m
	1112511	ISE01	-	Felt sealing. Qty in pack – 225 m

01

02

03

04

05

06

07

08

09

10

Image	Code	Article	Weight, kg/m	Application
	12651100	AYPC.SL160.0911	0.028	Foamed insert. Bar length - 2 m. Qty in pack - 240 m
	12651200	AYPC.SL160.0912	0.057	Foamed insert. Bar length - 2 m. Qty in pack - 162 m
	12651800	PE21x26	0.014	Thermal insert. Bar length - 2 m. Qty in pack - 300 m
	12657800	AYPC.SL160.0960	0.014	Thermal insert. Bar length - 2 m. Qty in pack - 620 m
	12657900	AYPC.SL160.0961	0.009	Thermal insert. Bar length - 2 m. Qty in pack - 900 m
	10910900	AYPC.W72.0911	0.011	Rebate insulation. Qty in pack - 180 m
	12657700	AYPC.SL160.0947	0.007	Rebate insulation. Bar length - 2 m. Qty in pack - 200 m
	10912500	PE21x8	0.004	Thermal insert. Qty in pack - 350 m
	10912800	PE50x15	0.019	Thermal insert. Qty in pack - 400 m

Image	Code	Article	Application
	104.14.600 104.14.700 104.14.800 104.14.900 104.15.000	100x26x1 100x26x2 100x26x3 100x26x4 100x26x5	Leveling support. Qty in pack: 26-50 mm - 1000 pcs., 56-62mm - 10 pcs
	112.13.400 112.13.500 112.13.600 1084.0300	100x32x1 100x32x2 100x32x3 100x32x5	
	112.13.700 112.13.800 112.13.900	100x38x1 100x38x2 100x38x3	
	112.18.100 112.18.200 112.18.300 112.19.800	100x44x1 100x44x2 100x44x3 100x44x5	
	112.18.400 112.18.500 112.18.600 1084.0500 1084.0600	100x50x1 100x50x2 100x50x3 100x50x4 100x50x5	
	112.19.100 112.19.200 112.19.300	100x56x1 100x56x2 100x56x3	
	112.19.400 112.19.500 112.19.600	100x62x1 100x62x2 100x62x3	

01

02

03

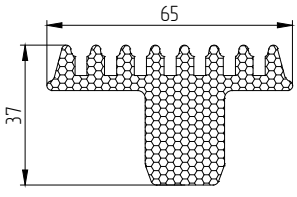
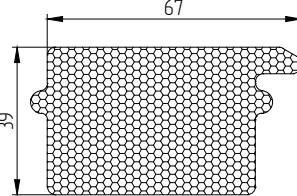
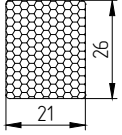
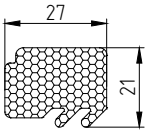
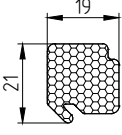
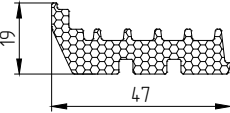
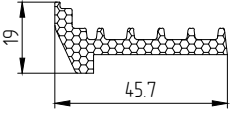
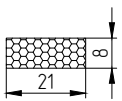
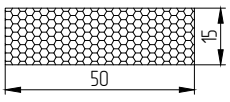
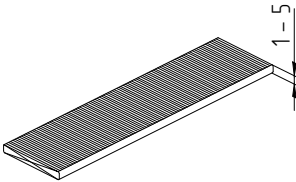
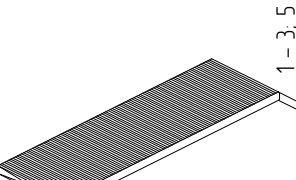
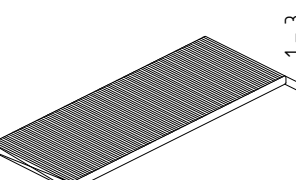
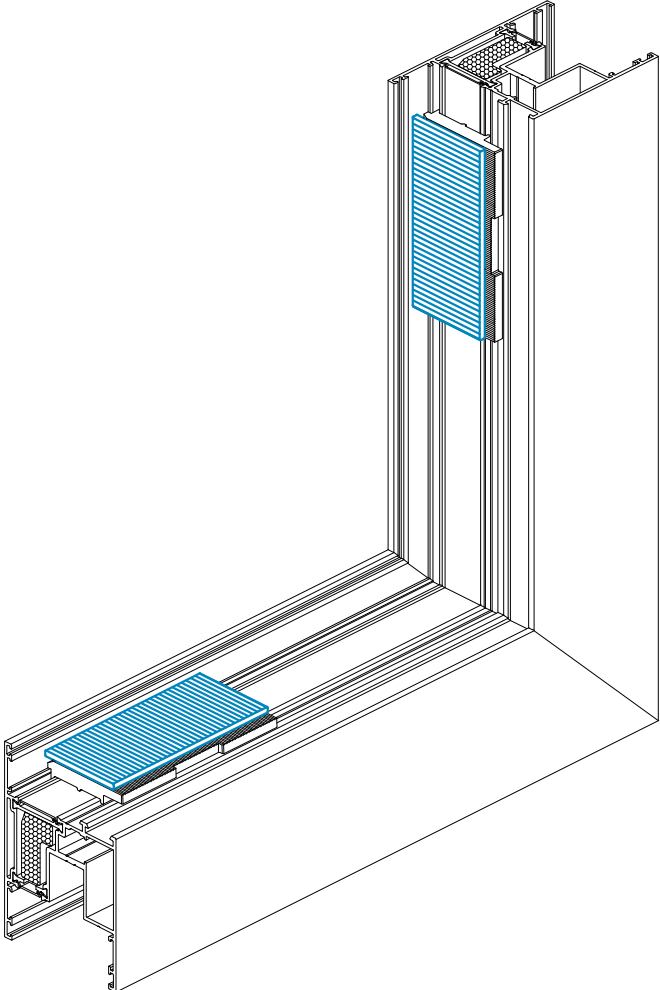
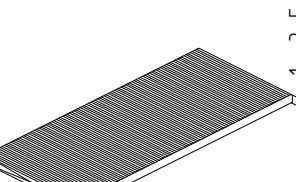
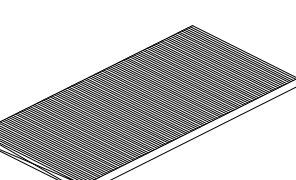
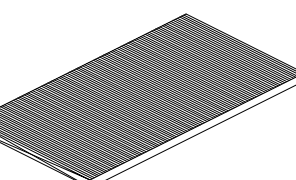
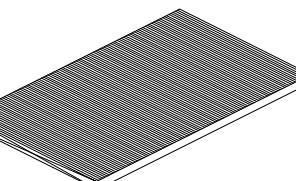
04

05

06

07

08

09

10

Image	Code	Article	Application
	12656600	AYPC.SL160.0939	<p>Bearing support. Qty in pack - 24 pcs</p>  <p>For frame/sash profiles</p> <p>AYPC.SL160.0102, AYPC.SL160.0103 / AYPC.SL160.0202</p>
	12656700	AYPC.SL160.0949	<p>Bearing support. Qty in pack - 24 pcs</p>  <p>For sash/transom profiles</p> <p>AYPC.SL160.0202 / AYPC.SL160.0301</p>

Image	Code	Article	Application
	12654100	FRK177	Rubber corner. Qty in pack - 24 pcs
			
			For sash profile
			AYPC.SL160.0202
	12654200	FRK178	Rubber corner. Qty in pack - 24 pcs
			
			For sash profile
			AYPC.SL160.0202
	12654300	FRK178-01	Rubber corner. Qty in pack - 24 pcs
			
			For sash profile
			AYPC.SL160.0202
	12951400	FRK179	Rubber corner. Qty in pack - 100 pcs
			
			For frame/sash/transom profiles
			AYPC.SL160.0102, AYPC.SL160.0103 / AYPC.SL160.0202 / AYPC.SL160.0301

01

02

03

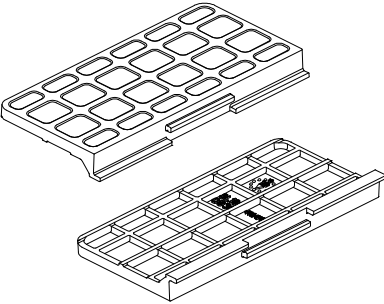
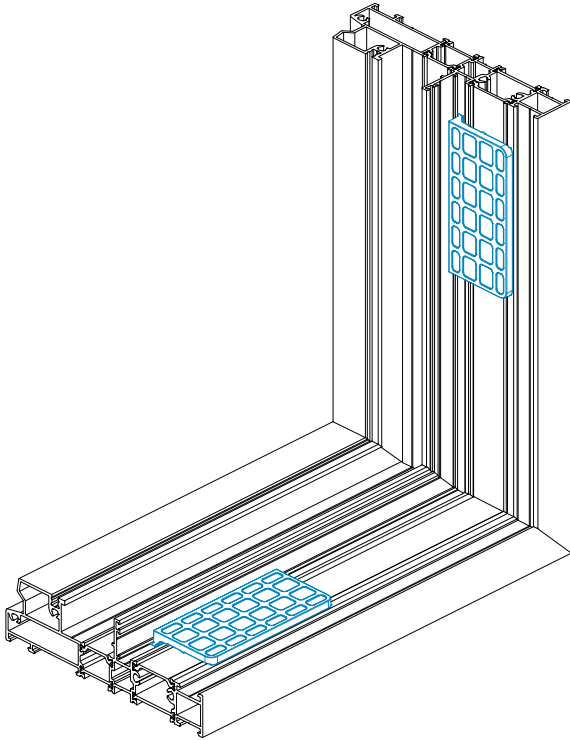
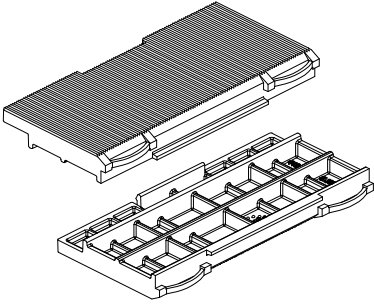
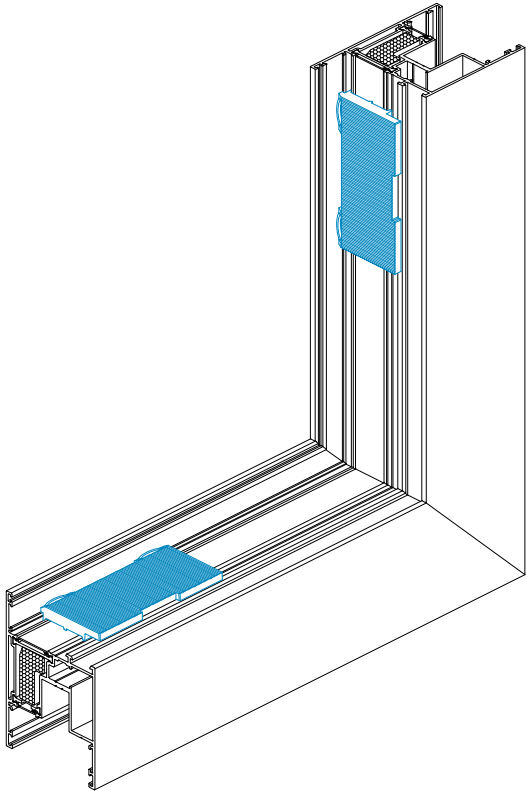
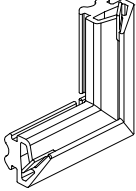
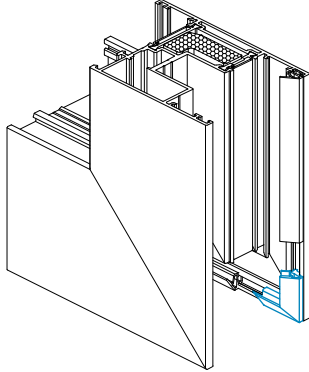
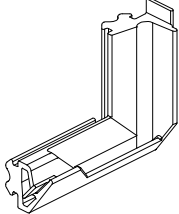
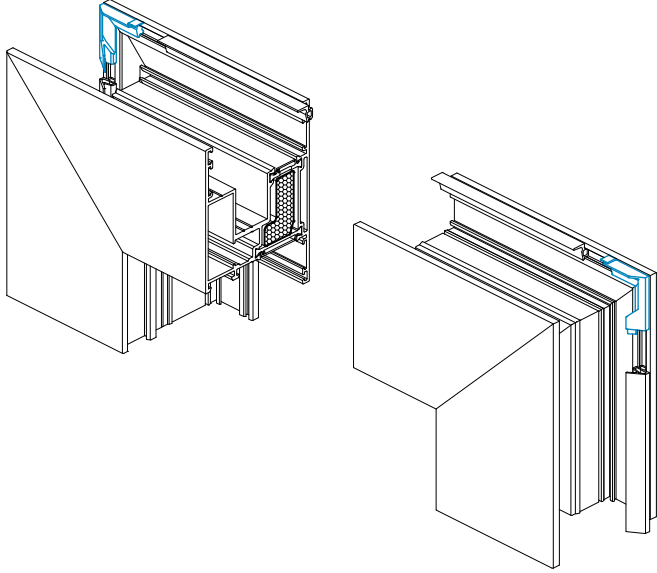
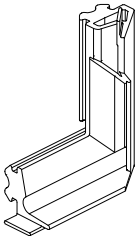
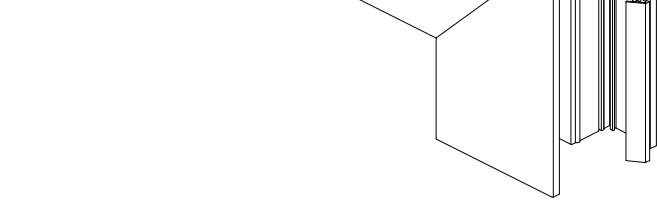
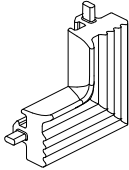
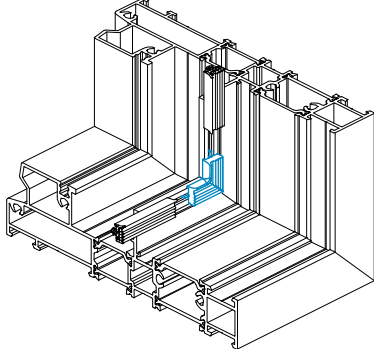
04

05

06

07

08

09

10

Image	Code	Article	Application
	12650600	AYPC.SL160.0905	<p>Stop. Qty in pack - 50 pcs <i>Kit doesn't include: self-tapping screw 4.8x70 DIN7981 - 1 pcs, decorative plug \varnothing 10 mm AYPC.SL160.0928 - 1 pcs, self-tapping screws 4.8x32 DIN7981 - 2 pcs</i></p>  <p>For sash profile</p> <p>AYPC.SL160.0202</p>
	12652000	AYPC.SL160.0920	<p>Drain profile. Bar length - 5.8 m</p>  <p>For frame profiles</p> <p>AYPC.SL160.0101, AYPC.SL160.0104</p>

Image	Code	Article	Application
	12652100	AYPC.SL160.0921	<p>Drain profile. Bar length - 5.8 m</p>  <p>For frame profiles</p> <p>AYPC.SL160.0101, AYPC.SL160.0104</p>
	12653600	AYPC.SL160.0922	<p>Drain profile. Bar length - 5.8 m</p>  <p>For frame profiles</p> <p>AYPC.SL160.0102, AYPC.SL160.0103</p>

01

02

03

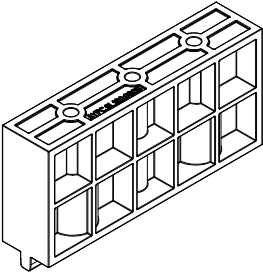
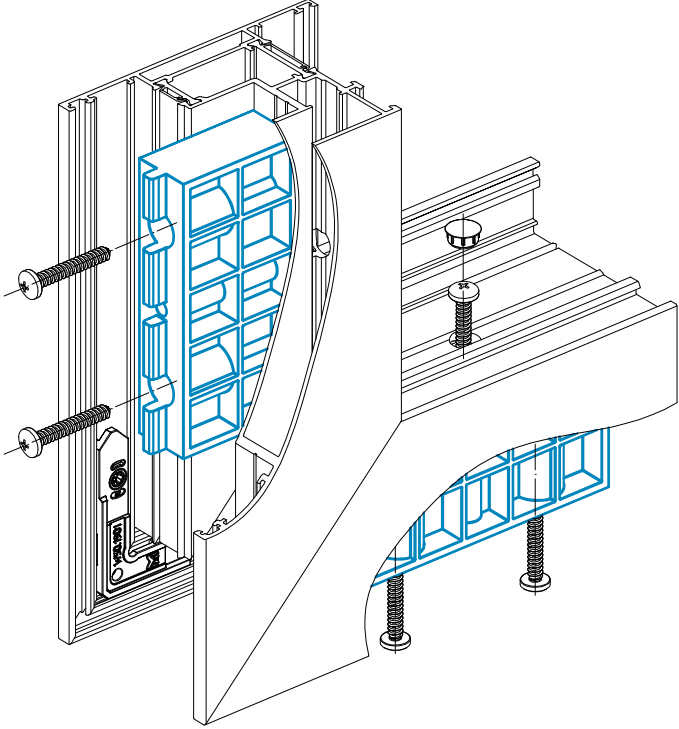
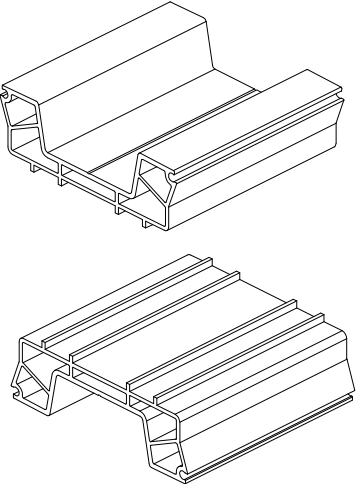
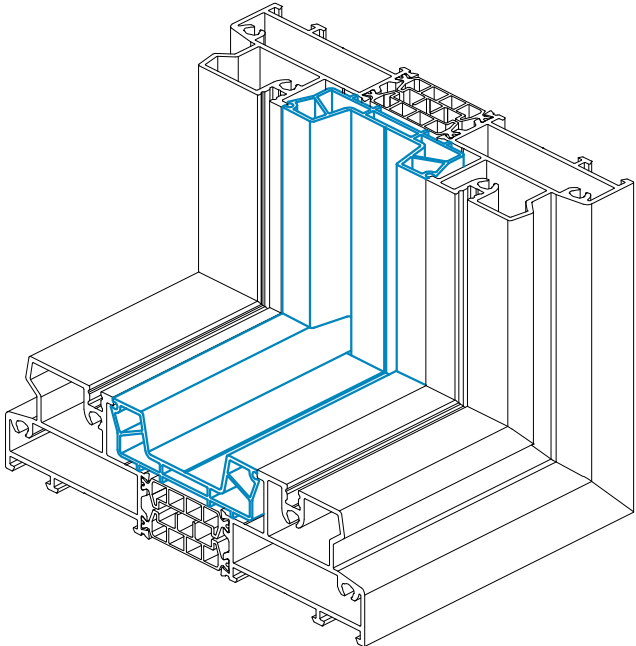
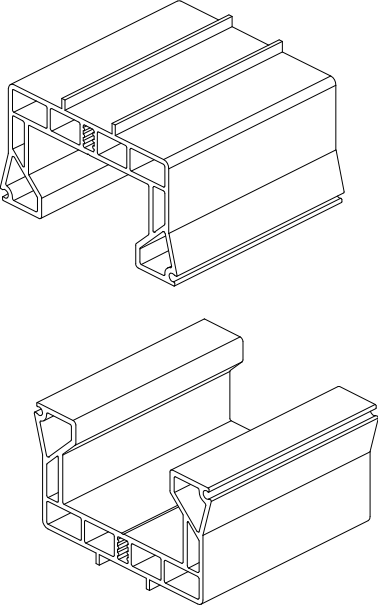
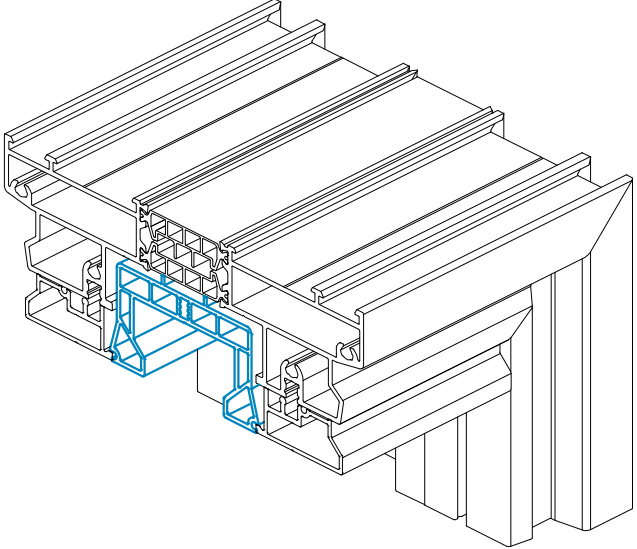
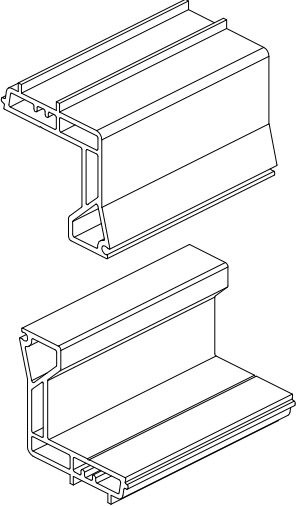
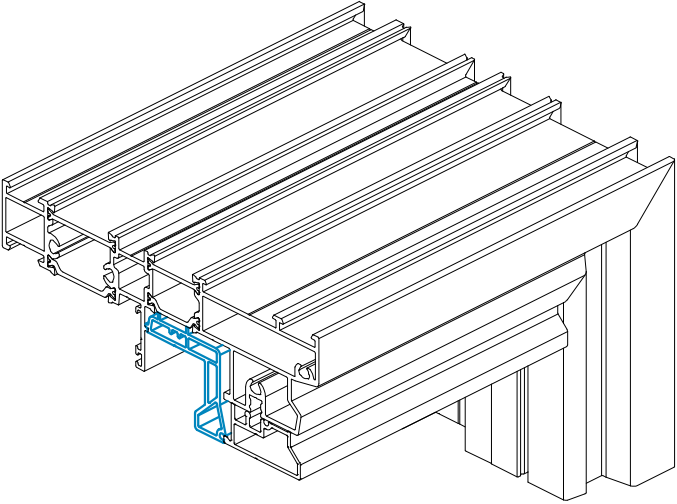
04

05

06

07

08

09

10

Image	Code	Article	Application
	12653700	AYPC.SL160.0923	<p>Drain profile. Bar length - 5.8 m</p>  <p>For frame profiles</p> <p>AYPC.SL160.0102, AYPC.SL160.0103</p>
	12653800	AYPC.SL160.0924	<p>Added profile. Bar length - 5.8 m</p>  <p>For frame profiles</p> <p>AYPC.SL160.0102, AYPC.SL160.0103</p>

Image	Code	Article	Application
	12654 700	AYPC.SL160.0925	<p data-bbox="982 280 1362 324">Plug for reinforcing profile. Qty in pack - 30 pcs <i>Kit doesn't include: self-tapping screw 3.9x9.5 DIN7981</i></p>  <p data-bbox="1082 2038 1263 2072">For reinforcing profile</p> <p data-bbox="1098 2083 1247 2116">AYPC.SL160.0702</p>

01

02

03

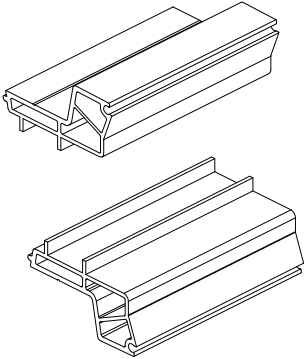
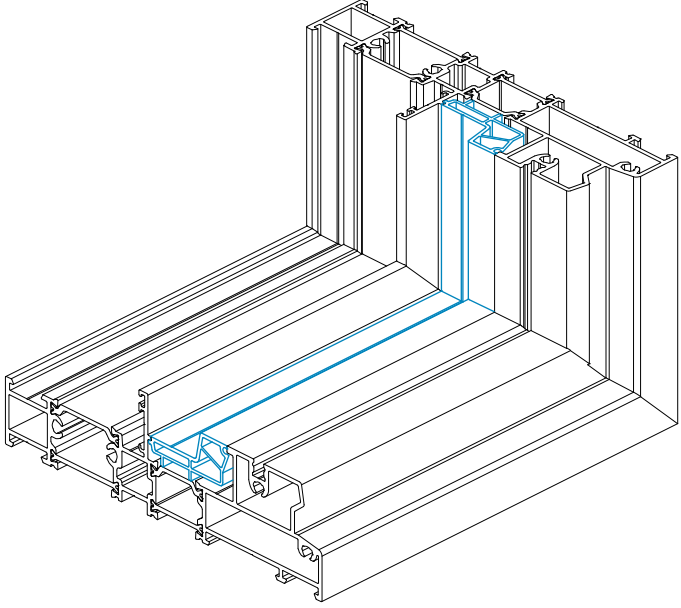
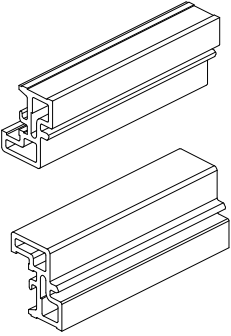
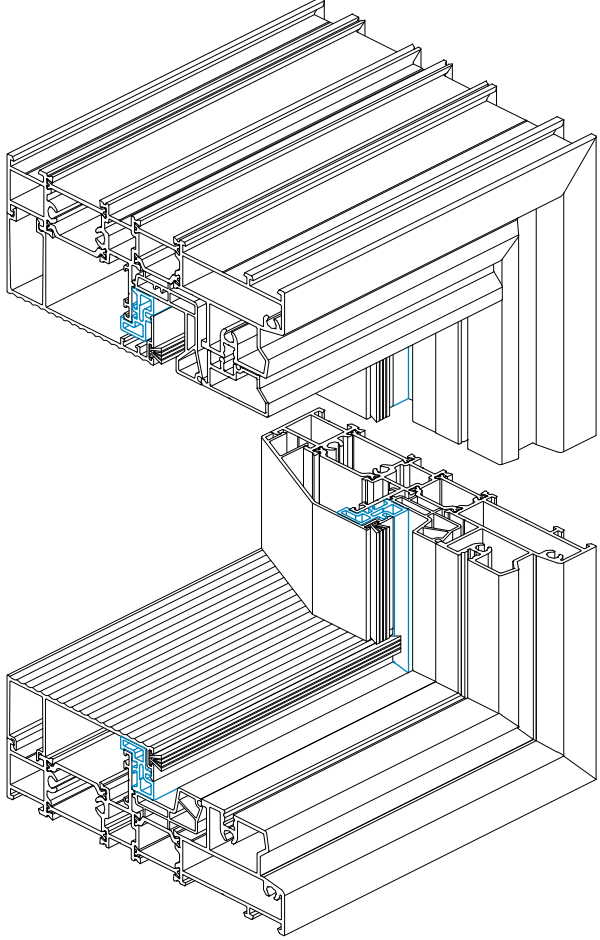
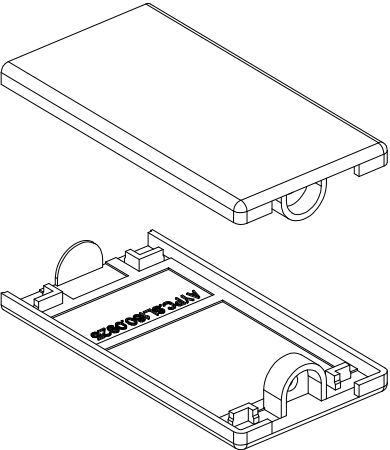
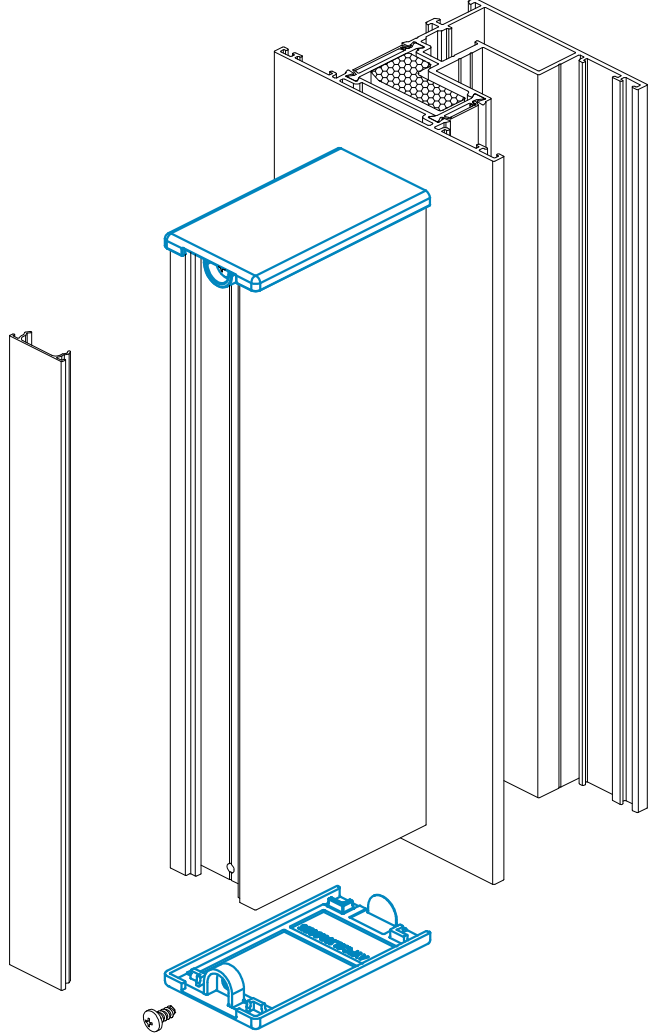
04

05

06

07

08

09

10

Image	Code	Article	Application
	12656500	AYPC.SL160.0929 Colour: black	<p>AYPC.SL160.0929 water drain plug. Qty in pack - 24 pcs AYPC.C48.0919M-01 water drain plug. Qty in pack - 100 pcs</p> 
	12656501	AYPC.SL160.0929 Colour: white	
	10827400	AYPC.C48.0919M-01 Colour: black	<p>For frame profiles</p> <p>AYPC.SL160.0929: AYPC.SL160.0101, AYPC.SL160.0102, AYPC.SL160.0104 AYPC.C48.0919M-01: AYPC.SL160.0101, AYPC.SL160.0102, AYPC.SL160.0103, AYPC.SL160.0104</p>
	10827401	AYPC.C48.0919M-01 Colour: white	
	10831500	AYPC.W62.0945	<p>AYPC.W62.0945 water drain plug. Qty in pack - 50 pcs AYPC.W62.0946 water drain plug. Qty in pack - 40 pcs</p> 
	10831700	AYPC.W62.0946	<p>For transom profile</p> <p>AYPC.SL160.0301</p>

Image	Code	Article	Application
	12657200	AYPC.SL160.0938	<p>Frame ledge profile. Bar length - 5,5 m</p> 
<p>AYPC.SL160.0901</p>	12654400	AYPC.SL160.0940	<p>Ledge profile kit. Qty in pack - 1 kit The kit includes: AYPC.SL160.0901 - 1 pcs, AYPC.SL160.0902 - 1 pcs, AYPC.SL160.0904-6 pcs, AYPC.SL160.0914- 1 pcs, AYPC.SL160.0916- 1 pcs, mounting screw M4x10 DIN914 - 6 pcs, self-tapping screw 3.9x9.5 DIN7981 - 4 pcs</p>
			
<p>AYPC.SL160.0902</p>			
			
<p>AYPC.SL160.0914</p>			
			
<p>AYPC.SL160.0916</p>			
			
<p>AYPC.SL160.0904</p>			
			

01

02

03

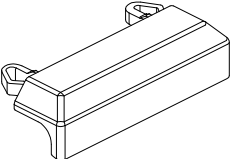
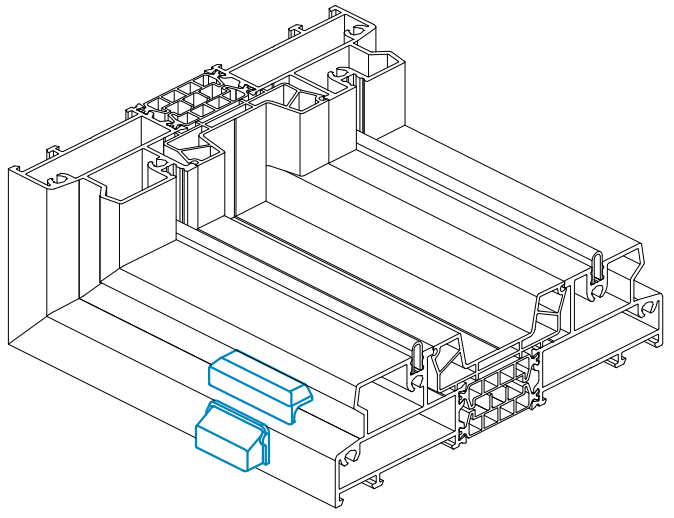
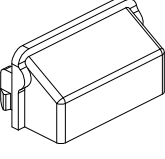
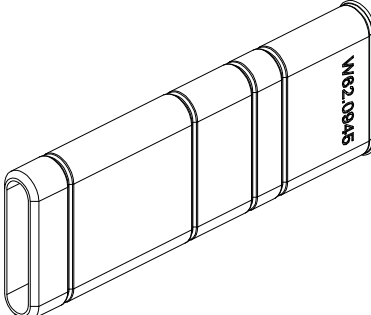
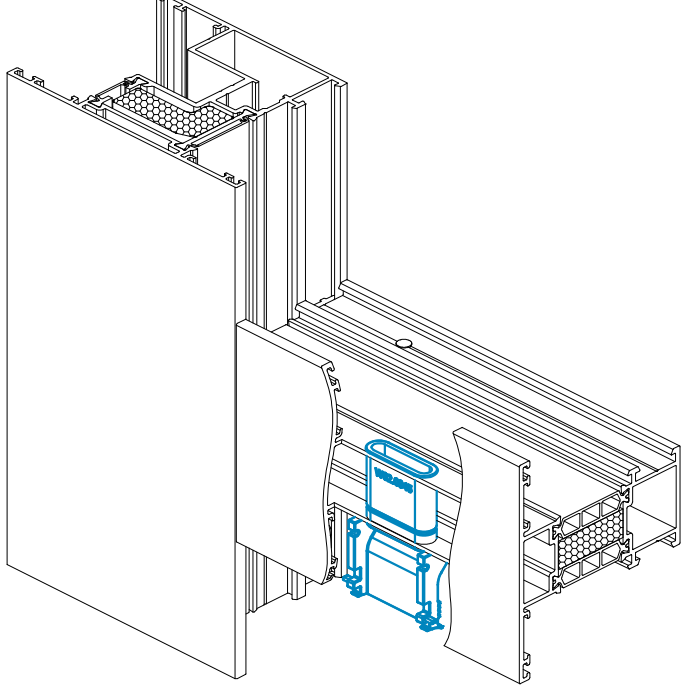
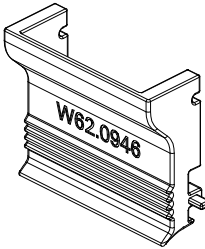
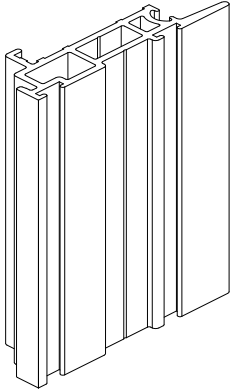
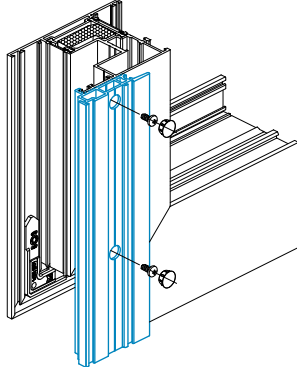
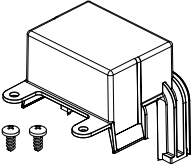
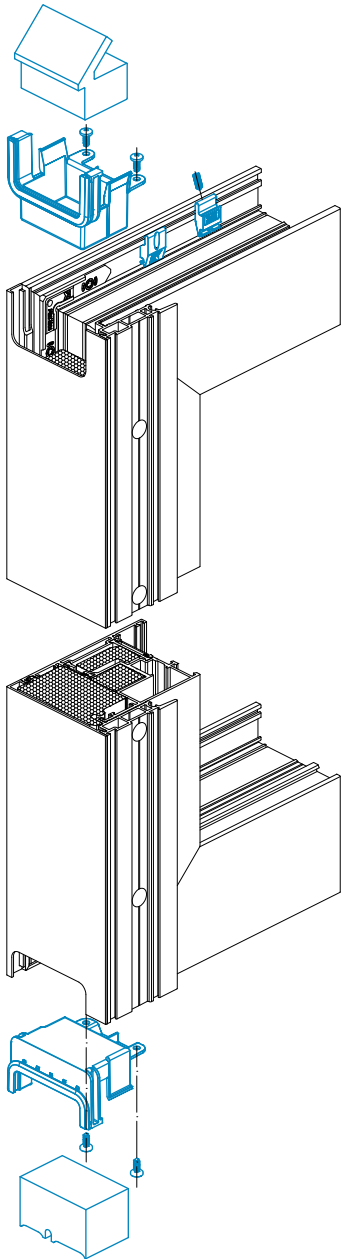
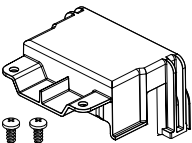
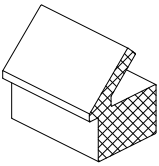
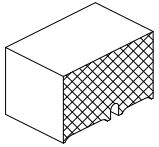
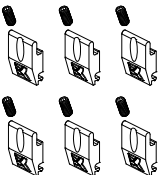
04

05

06

07

08

09

10

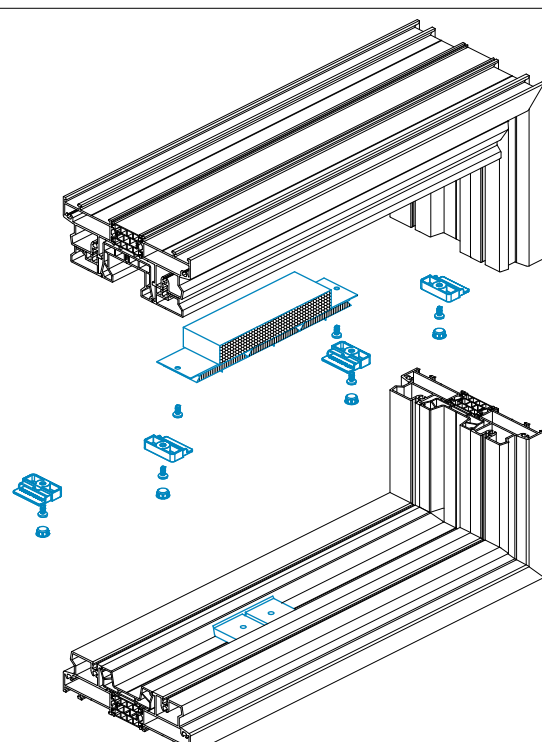
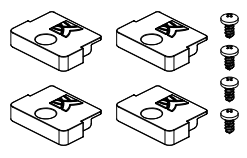
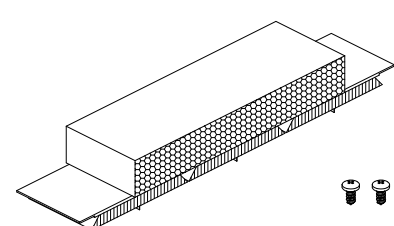
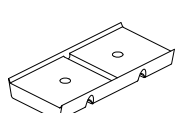
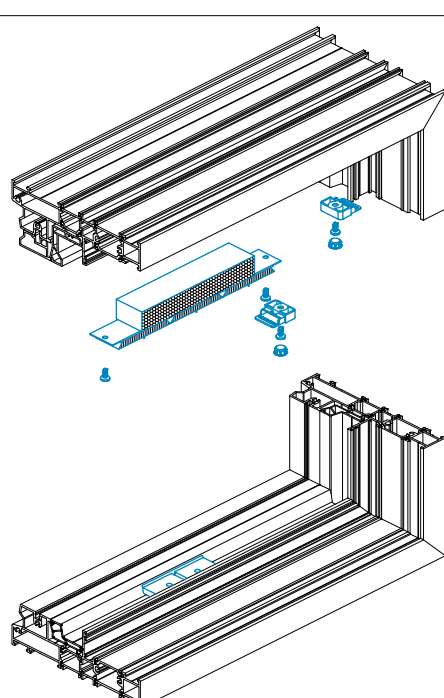
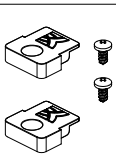
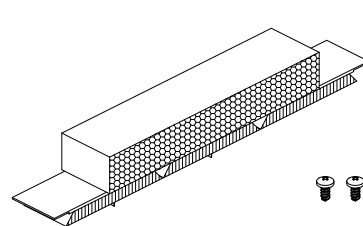

Image	Code	Article	Application
AYPC.SL160.0908	12654500	AYPC.SL160.0941	<p>Sealing block. Qty in pack – 1 kit.</p> <p><i>The kit includes: AYPC.SL160.0908-4 pcs, AYPC.SL160.0913-1 pcs, AYPC.SL160.0915 – 1 pcs, AYPC.SL160.0928 (black) – 4 pcs, self-tapping screw 4.2x9.5 DIN7981 – 6 pcs</i></p> 
			
AYPC.SL160.0913			
			
AYPC.SL160.0915			
			
AYPC.SL160.0928	12654600	AYPC.SL160.0942	<p>Sealing block. Qty in pack – 1 kit.</p> <p><i>The kit includes: AYPC.SL160.0910-2 pcs, AYPC.SL160.0913-01-1 pc, AYPC.SL160.0932 – 1 pcs, AYPC.SL160.0928 (black) – 2 pcs, self-tapping screw 4.2x9.5 DIN7981 – 4 pcs</i></p> 
AYPC.SL160.0910			
			
AYPC.SL160.0913-01			
			
AYPC.SL160.0928			
			
AYPC.SL160.0932	12654600	AYPC.SL160.0942	<p>For frame profiles</p> <p>AYPC.SL160.0101, AYPC.SL160.0104</p>
			
	12654600	AYPC.SL160.0942	<p>For frame profiles</p> <p>AYPC.SL160.0102, AYPC.SL160.0103</p>
			

Image	Code	Article	Application
	12657300	AYPC.SL160.0943	<p>Encapsulating insert. Qty in pack - 20 pcs</p>  <p>For frame profiles</p> <p>AYPC.SL160.0101, AYPC.SL160.0102, AYPC.SL160.0104</p>
	12657400	AYPC.SL160.0944	<p>Encapsulating insert. Qty in pack - 20 pcs</p>  <p>For frame profile</p> <p>AYPC.SL160.0104</p>
	12657500	AYPC.SL160.0945	<p>Encapsulating insert. Qty in pack - 20 pcs</p>  <p>For frame profiles</p> <p>AYPC.SL160.0101, AYPC.SL160.0103, AYPC.SL160.0104</p>
	12657600	AYPC.SL160.0946	<p>Encapsulating insert. Qty in pack - 20 pcs</p>  <p>For frame profiles</p> <p>AYPC.SL160.0101, AYPC.SL160.0102, AYPC.SL160.0103, AYPC.SL160.0104</p>

01

02

03

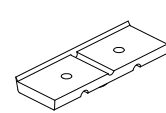
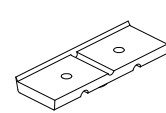
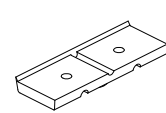
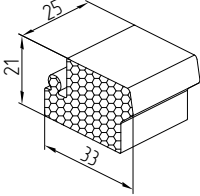
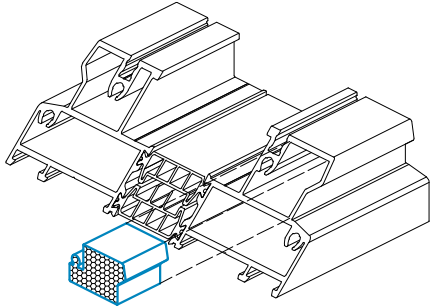
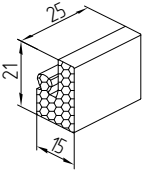
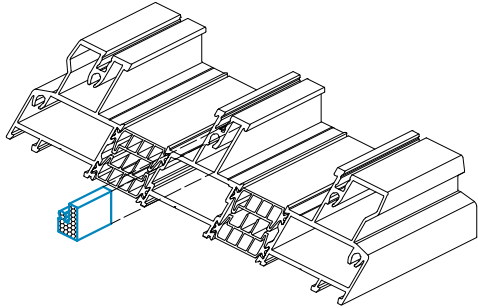
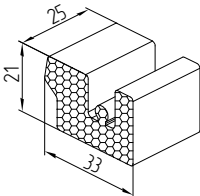
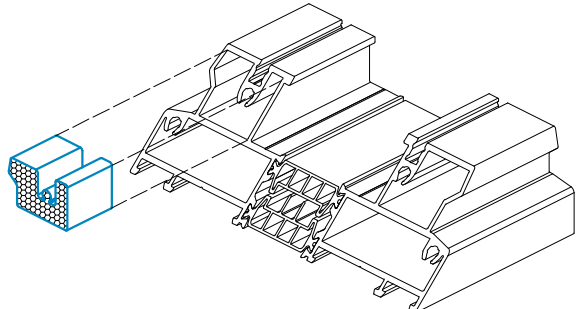
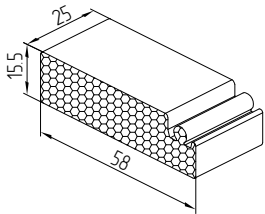
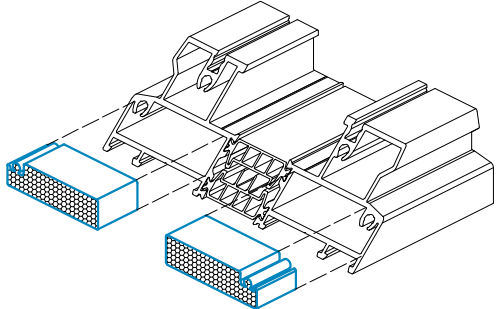
04

05

06

07

08

09

10

Image	Code	Article	Application
	10811800	AYPC.W62.0951-03	<p>T-cleat. Qty in pack – 60 kits. <i>Kit includes: AYPC.W62.0950-03 – 1 pcs, 3.9x16-A2 DIN7981 – 2 pcs, dowels 5x10 DIN6325D – 2 pcs</i> <i>Initial profile – AYPC.W62.0701</i></p>  <p>For sash profile AYPC.SL160.0202</p>
	10827900	AYPC.W62.0973-01	<p>T-cleat. Qty in pack – 56 kits. <i>Kit includes: AYPC.W62.0972-01 – 1 pcs, 3.9x9.5-A2 DIN7981 – 1 pcs, dowels 5x10 DIN6325D – 2 pcs</i> <i>Initial profile – AYPC.W62.0705</i></p>  <p>For transom profile AYPC.SL160.0301</p>

Image	Code	Article	Application
	12210000	00336	<p>00336 connecting corner. Qty in pack - 100 pcs</p>  <p>For frame profile</p> <p>AYPC.SL160.0101</p>
	12652300		<p>AYPC.SL160.0950 corner cleat. Qty in pack - 60 pcs <i>Kit doesn't include: self-tapping screws 3.9x13-A2 DIN7982 - 2 pcs</i> <i>Initial profile - AYPC.GS106.0701</i></p>  <p>For frame/sash profiles</p> <p>AYPC.SL160.0102, AYPC.SL160.0103 / AYPC.SL160.0202</p>
	12652400	AYPC.SL160.0950-01	<p>AYPC.SL160.0950-01 corner cleat. Qty in pack - 10 pcs <i>Kit doesn't include: self-tapping screws 3.9x13-A2 DIN7982 - 2 pcs</i> <i>Initial profile - AYPC.GS106.0701</i></p>  <p>For frame profiles</p> <p>AYPC.SL160.0101, AYPC.SL160.0102, AYPC.SL160.0103, AYPC.SL160.0104</p>

01

02

03

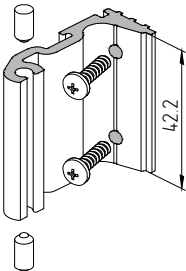
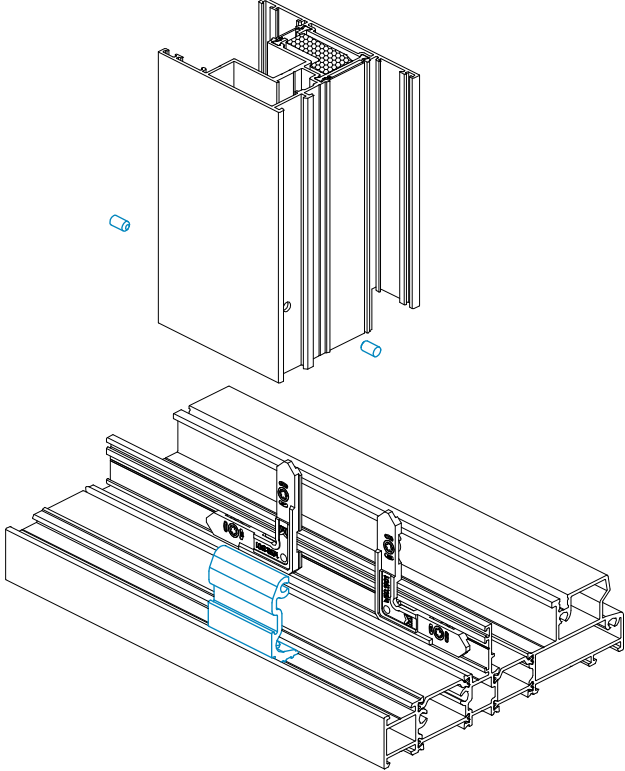
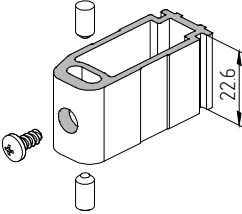
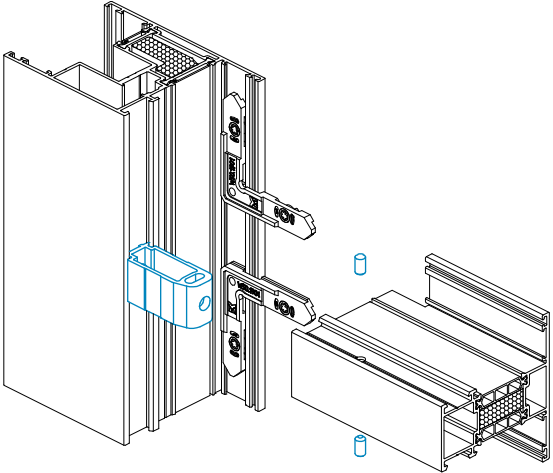
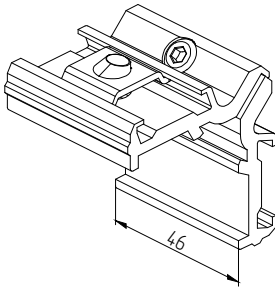
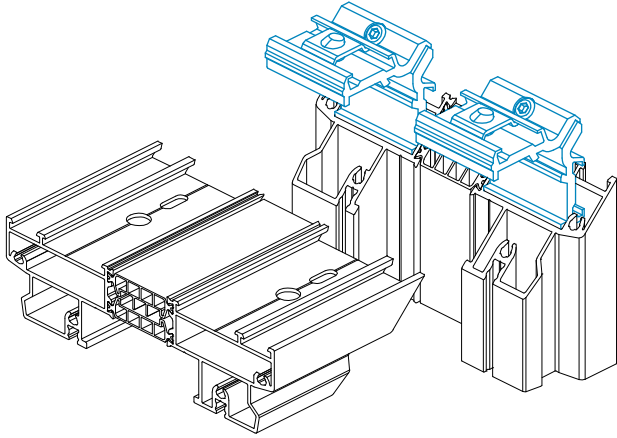
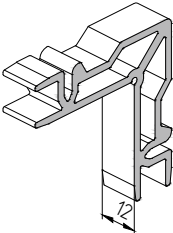
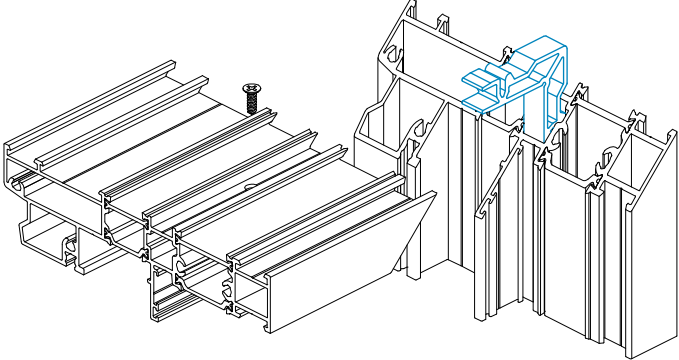
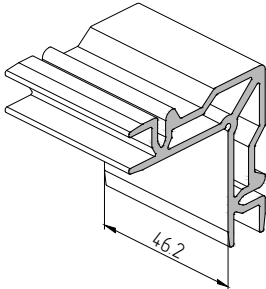
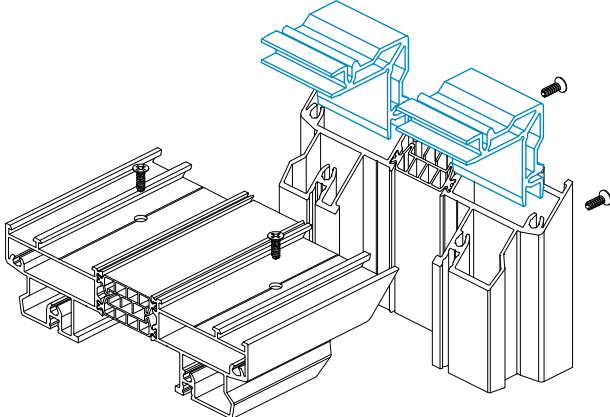
04

05

06

07

08

09

10

Image	Code	Article	Application
	12652900	AYPC.SL160.0950-02	<p>AYPC.SL160.0950-02 corner cleat. Qty in pack – 40 pcs <i>Kit doesn't include: self-tapping screw 3.9x13-A2 DIN7982 – 2 pcs Initial profile – AYPC.GS106.0701</i></p>  <p>For frame profiles AYPC.SL160.0102, AYPC.SL160.0103</p>
	12656000	AYPC.SL160.0950-03	<p>AYPC.SL160.0950-03 corner cleat. Qty in pack – 100 pcs <i>Kit doesn't include: self-tapping screws 3.9x13-A2 DIN7982 – 2 pcs Initial profile – AYPC.GS106.0701</i></p>  <p>For frame profile AYPC.SL160.0104</p>
	12652600	AYPC.SL160.0951-01	<p>AYPC.SL160.0951-01 corner cleat. Qty in pack – 100 pcs <i>Kit doesn't include: dowels 5x10 DIN6325D – 2 pcs Initial profile – AYPC.C4.8.0705</i></p>  <p>For sash profile AYPC.SL160.0202</p>

Image	Code	Article	Application
	12656800	AYPC.SL160.0953	Frame connector AYPCL160.0953. Qty in pack – 10 pcs <i>Kit doesn't include: screws M6x16-A2 DIN7991 – 4 pcs</i>
			For frame profiles
			AYPC.SL160.0101, AYPCL160.0102, AYPCL160.0103, AYPCL160.0104
	12656900	AYPC.SL160.0954	AYPCL160.0954 frame connector. Qty in pack – 10 pcs <i>Kit doesn't include: screws M6x16-A2 DIN7991 – 2 pcs</i>
			For frame profile
			AYPC.SL160.0104
	12657000	AYPC.SL160.0954-01	AYPCL160.0954-01 frame connector. Qty in pack – 10 pcs <i>Kit doesn't include: screws M6x16-A2 DIN7991 – 2 pcs</i>
			For frame profiles
			AYPC.SL160.0102, AYPCL160.0103
	12657100	AYPC.SL160.0954-02	AYPCL160.0954-02 frame connector. Qty in pack – 10 pcs <i>Kit doesn't include: screws M6x16-A2 DIN7991 – 2 pcs</i>
			For frame profiles
			AYPC.SL160.0102, AYPCL160.0103

01

02

03

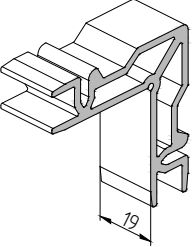
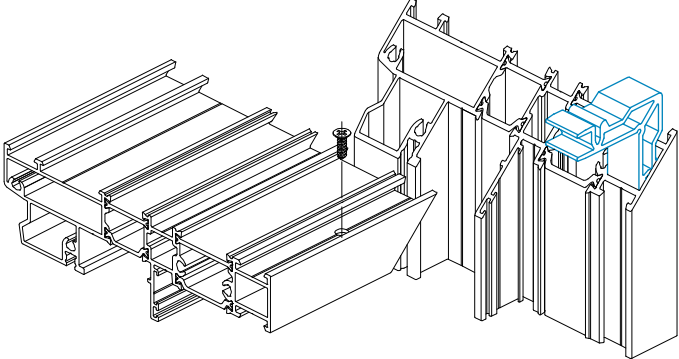
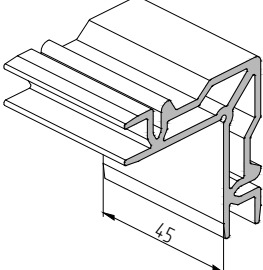
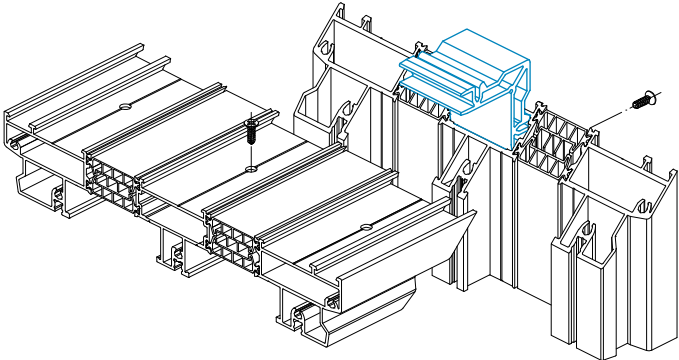
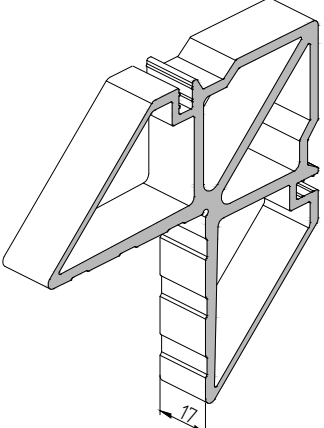
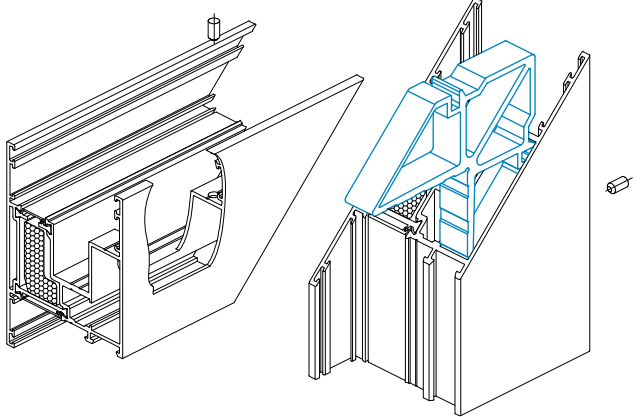
04

05

06

07

08

09

10

Image	Code	Article	Application
	12430100	AYPC.W50.1901	<p>AYPC.W50.1901 corner cleat. Qty in pack - 1 pcs</p>  <p>For frame/sash/transom profiles</p> <p>AYPC.SL160.0102, AYPC.SL160.0103 / AYPC.SL160.0202 / AYPC.SL160.0301</p>
	12652800	AYPC.SL160.1950	<p>Stainless steel track. Qty in pack - 6.5 m</p>  <p>For frame profiles</p> <p>AYPC.SL160.0101, AYPC.SL160.0102, AYPC.SL160.0103, AYPC.SL160.0104</p>
	10813600	AYPC.W62.0957	<p>Chevron. Qty in pack - 200 pcs</p>  <p>For adapter profile</p> <p>AYPC.SL160.0501</p>

Image	Code	Article	Application
	10828400	AYPC.W62.0940	<p>Mounting plate. Qty in pack - 150 pcs</p> 
	10828500	AYPC.W62.0940-01	<p>Mounting plate. Qty in pack - 150 pcs</p> 
	12655500	AYPC.SL160.0933	<p>AYPC.SL160.0933 interlock plug Qty in pack - 12 pcs</p>  <p>For coupling profile</p> <p>AYPC.SL160.0504</p>

01

02

03

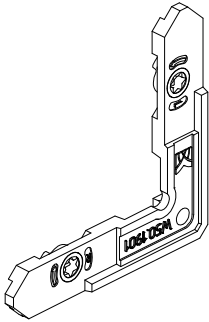
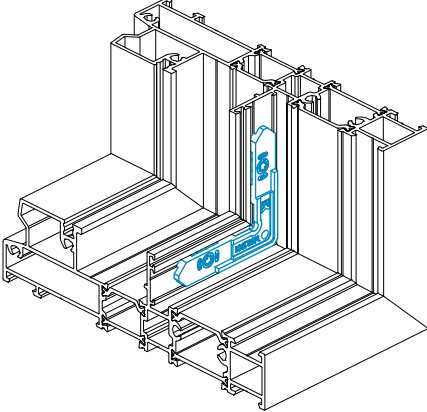
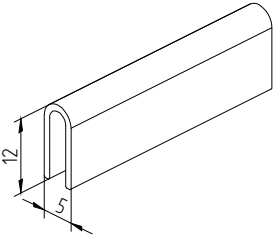
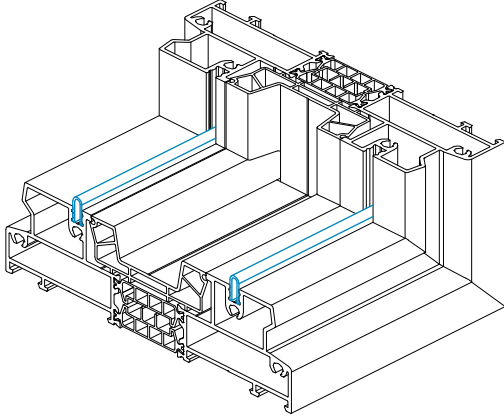
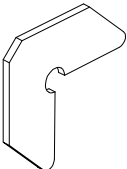
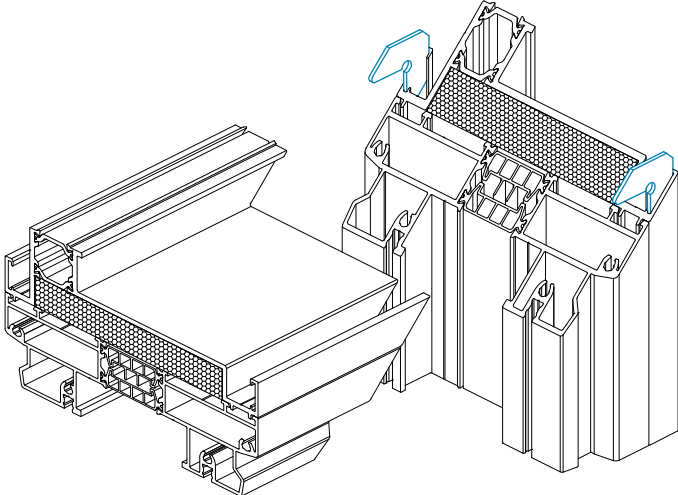
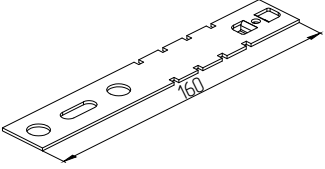
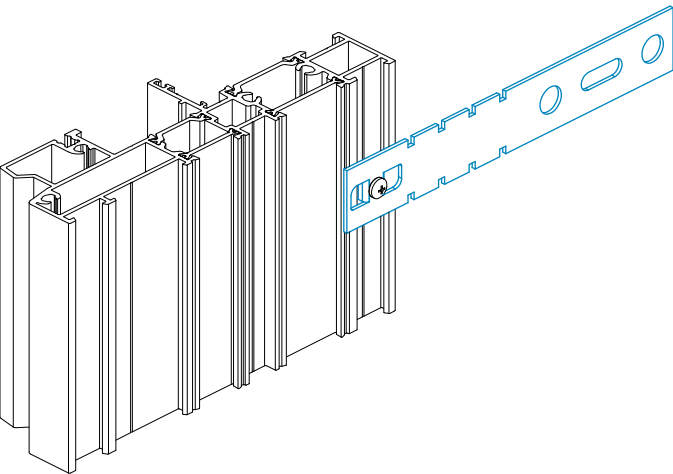
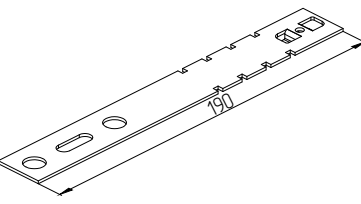
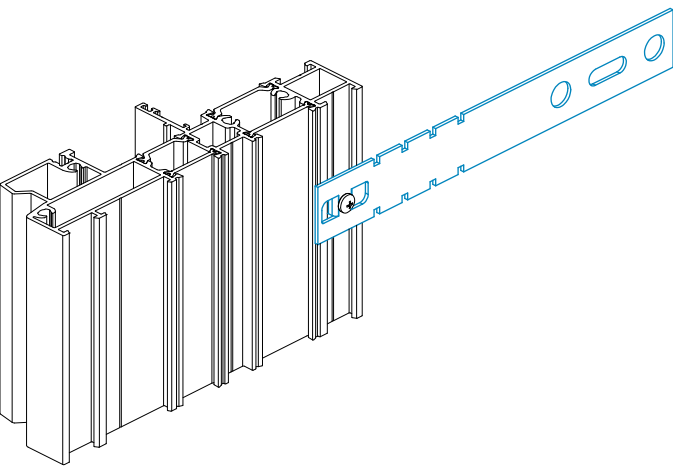
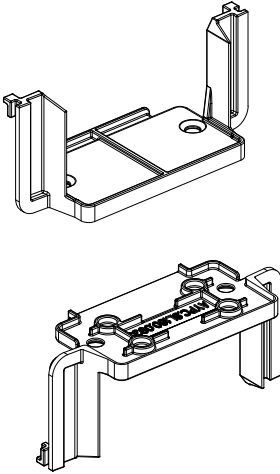
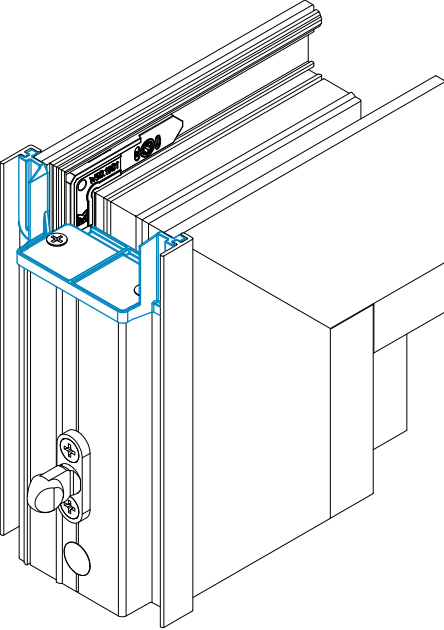
04

05

06

07

08

09

10

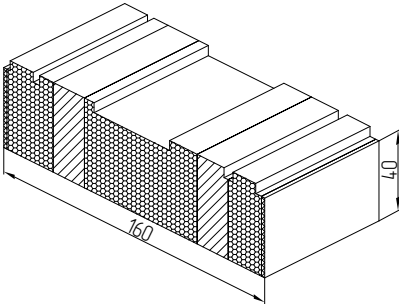
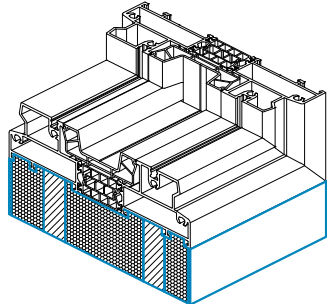
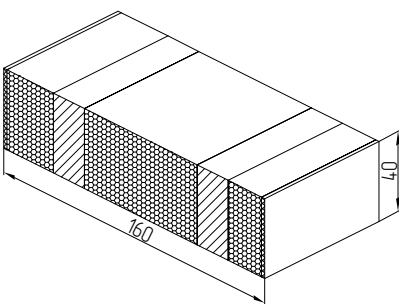
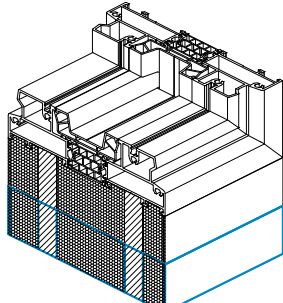
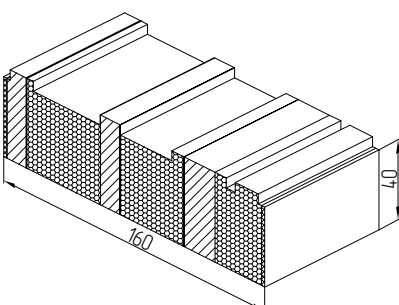
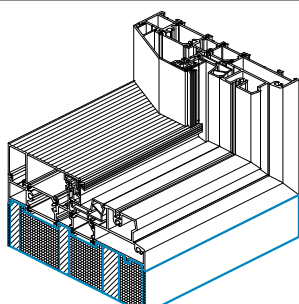
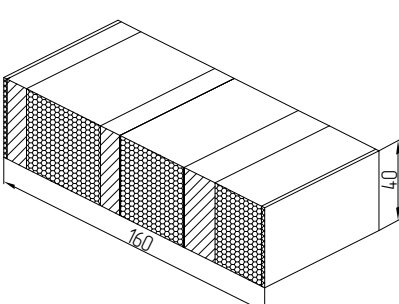
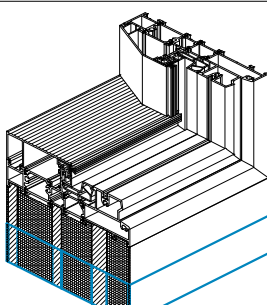
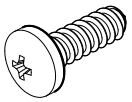
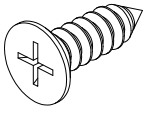
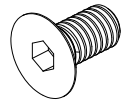

Image	Code	Article	Application
	12655600	AYPC.SL160.0934	<p>AYPC.SL160.0934 supporting block. Bar length – 4 m</p>  <p>For frame profile</p> <p>AYPC.SL160.0101</p>
	12655700	AYPC.SL160.0935	<p>AYPC.SL160.0935 supporting block. Bar length – 4 m</p>  <p>For frame profile</p> <p>AYPC.SL160.0101</p>
	12655800	AYPC.SL160.0936	<p>AYPC.SL160.0936 supporting block. Bar length – 4 m</p>  <p>For frame profiles</p> <p>AYPC.SL160.0102, AYPCL160.0103</p>
	12655900	AYPC.SL160.0937	<p>AYPC.SL160.0937 supporting block. Bar length – 4 m</p>  <p>For frame profiles</p> <p>AYPC.SL160.0102, AYPCL160.0103</p>

Image	Code	Article	Qty in pack
	18101000	3.9x9.5 DIN7981	100 pcs
	18100600	3.9x13 DIN7981	
	18102300	3.9x25 DIN7981	
	18105100	4.2x9.5 DIN7981	
	18100300	4.2x38 DIN7981	
	18101200	4.8x16 DIN7981	
	18100200	4.8x32 DIN7981	
	-	4.8x70 DIN7981	
Self-tapping screw with hidden head	18100700	3.9x13 DIN7982	100 pcs
	-	4.8x60 DIN7982	
	-	4.8x70 DIN7982	
	-	4.8x80 DIN7982	
Screw	18116500	M6x16 DIN7991	100 pcs
			
Pin	18112400	5x10 DIN6325D	100 pcs.  Supplied only by Alutech. Can be substituted by 5x10 DIN6325 pin.
			
Decorative plug Ø10	12655100	AYPC.SL160.0928 Colour: black	100 pcs
	12655101	AYPC.SL160.0928 Colour: white	

01

02

03

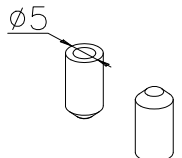
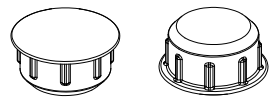
04

05

06

07

08

09

10



ALUTECH ALT SL160

Lifting and sliding constructions

EQUIPMENT

01

02

03

04

05

06

07

08

09

10

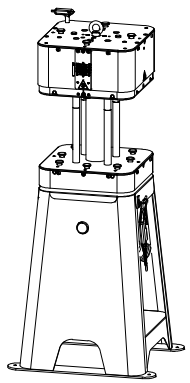
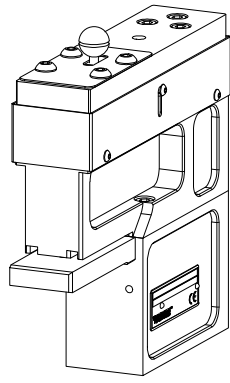
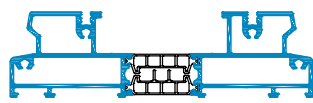
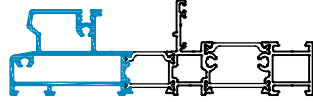
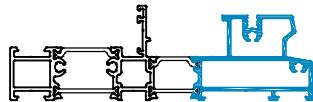
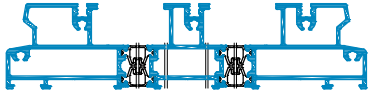
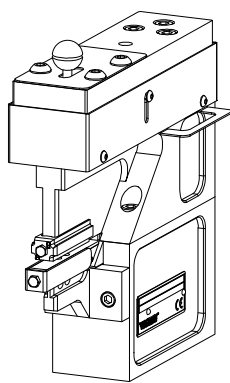
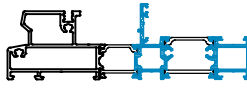
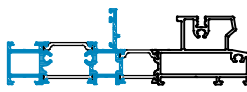
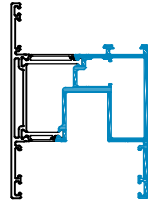
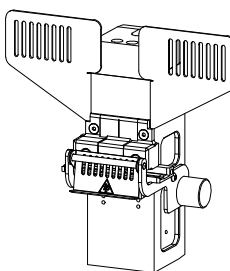
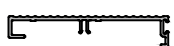
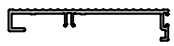
Name	Code	Article	General view	Operations	Machinable profile		
					Article	Drawing	
Universal punching tool	18516000	2990021		-	-	-	-
Cassette tool	18516100	4110000		∅10.5 6x14 ∅6	SL160.0101		08.03
					SL160.0102		
				∅6	SL160.0103		08.04
					SL160.0104		
Cassette tool	18516200	4110001		∅6	SL160.0102		08.04
					SL160.0103		
				∅5	SL160.0202		08.06
Cassette tool	18516300	4110002		5.7x34	SL160.0810		08.09
					SL160.0811		08.16

01

02

03

04

05







06

07

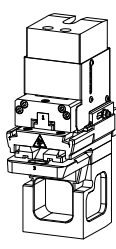
08

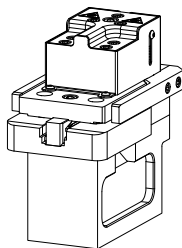
09

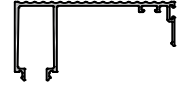
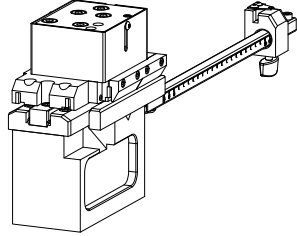
10

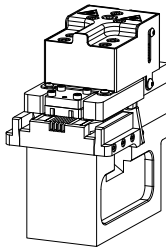
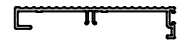
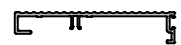
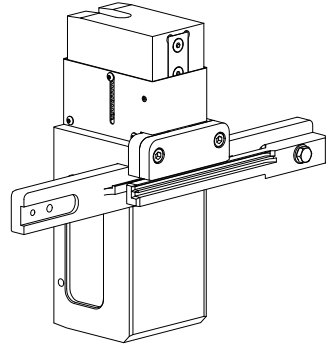
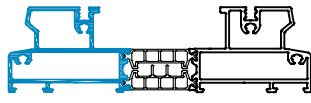
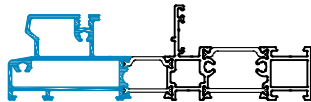
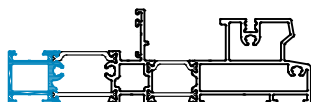
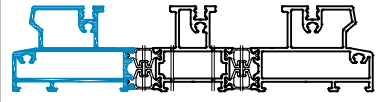
Name	Code	Article	General view	Operations	Machinable profile		
					Article	Drawing	
Cassette tool	18516400	4110003		63x20 63x34.5 3x3 4.9x20 4.9x34.5 20x25	SL160.0802		08.25 08.26
Cassette tool	18516500	4110005		25x28	SL160.0806		08.36
				25x28 40x13	SL160.0808		
Cassette tool	18516600	4110006		14x23 ∅4	SL160.0804		08.31
					SL160.0805		
Cassette tool	18516700	4110008		58x14 58x25	SL160.0810		08.34
					SL160.0811		
Cassette tool	18521600	4110010		25x7	SL160.0101		08.08
					SL160.0102		08.10
					SL160.0103		08.12
					SL160.0104		08.14

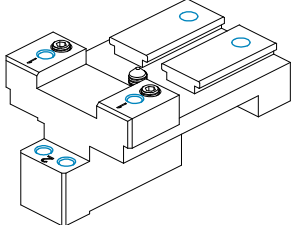
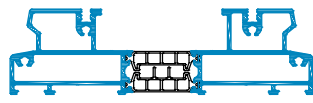
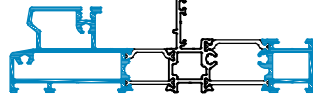
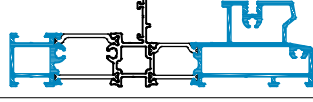
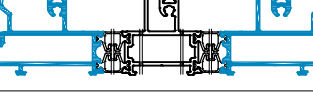
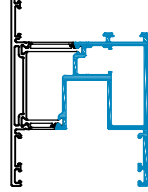
Name	Code	Article	General view	Operations	Machinable profile		
					Article	Drawing	
Jig	18514600	AYPC.SL160.1900		∅6	SL160.0101		08.03
					SL160.0102		08.04
					SL160.0103		
					SL160.0104		
				∅5	SL160.0202		08.06

01

02

03

04

05

06

07

08

09

10



ALUTECH ALT SL160

Lifting and sliding constructions

TABLE OF GLAZING

01

02

03

04

05

06

07

08

09

10

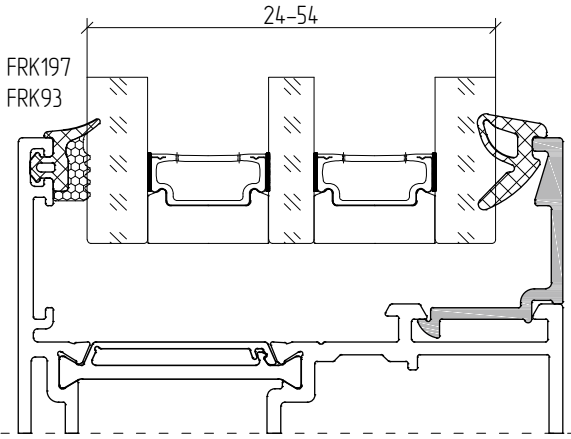
Profile system	Infill unit thickness, mm	External gasket			
		FRK93		FRK197	
		Internal gasket	Glass bead	Internal gasket	Glass bead
	24	FRK192, FRK194	AYPC.C48.0608	FRK192, FRK194	AYPC.C48.0608
	26	FRK191, FRK193	AYPC.C48.0608	FRK191, FRK193	AYPC.C48.0608
	28	FRK192, FRK194	AYPC.C48.0607	FRK192, FRK194	AYPC.C48.0607
	30	FRK191, FRK193	AYPC.C48.0607	FRK191, FRK193	AYPC.C48.0607
	32	FRK192, FRK194	AYPC.C48.0606	FRK192, FRK194	AYPC.C48.0606
	34	FRK191, FRK193	AYPC.C48.0606	FRK191, FRK193	AYPC.C48.0606
	36	FRK192, FRK194	AYPC.C48.0605	FRK192, FRK194	AYPC.C48.0605
	38	FRK191, FRK193	AYPC.C48.0605	FRK191, FRK193	AYPC.C48.0605
	40	FRK192, FRK194	AYPC.C48.0604	FRK192, FRK194	AYPC.C48.0604
	42	FRK191, FRK193	AYPC.C48.0604	FRK191, FRK193	AYPC.C48.0604
	44	FRK192, FRK194	AYPC.C48.0603	FRK192, FRK194	AYPC.C48.0603
	46	FRK191, FRK193	AYPC.C48.0603	FRK191, FRK193	AYPC.C48.0603
	48	FRK192, FRK194	AYPC.C48.0602	FRK192, FRK194	AYPC.C48.0602
	50	FRK191, FRK193	AYPC.C48.0602	FRK191, FRK193	AYPC.C48.0602
	52	FRK192, FRK194	AYPC.C48.0601	FRK192, FRK194	AYPC.C48.0601
54	FRK191, FRK193	AYPC.C48.0601	FRK191, FRK193	AYPC.C48.0601	

Infill units	External gasket		Internal gasket			
						
Article	FRK93	FRK197	FRK191	FRK192	FRK193	FRK194



Use bearing and leveling supports.

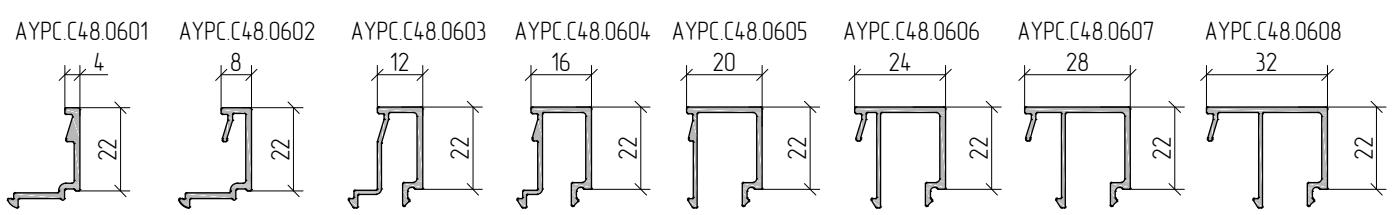
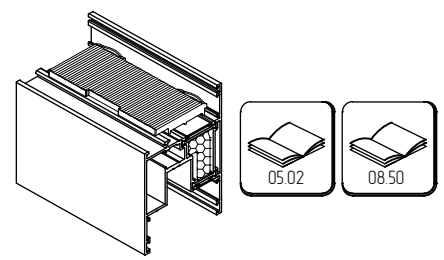

Note:
Data given in the table is for reference only, the values are suitable for preliminary calculation. In common use, it is necessary to check their validity on the basis of actual parameters, such as accuracy of infill unit manufacturing (tolerance); accuracy of gasket manufacturing (tolerance); conditions of gasket installation and system assemblage, tolerances for glass bead profile and tolerances for assemblage of the combined profile.
For correct system operation the gaskets must be tightened.

Application table of bearing and leveling supports for infill

Profile system	Infill unit thickness, mm	Bearing support	Leveling support
	24-32	AYPC.SL160.0939	100x38x1(3)
	34-38		100x44x1(3)
	40-44		100x50x1(3)
	46-50		100x56x1(3)
	52-54	-	100x62x2 100x62x3
	24-32	AYPC.SL160.0949	100x38x1(3)
	34-38		100x44x1(3)
	40-44		100x50x1(3)
	46-50		100x56x1(3)
	52-54	-	100x44x5 100x62x2 100x62x3

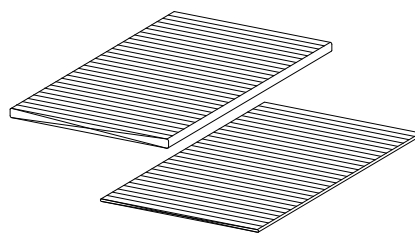
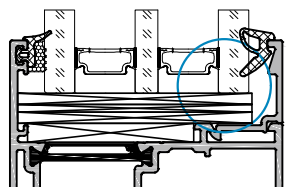

For correct positioning it is recommended to instal on silicone

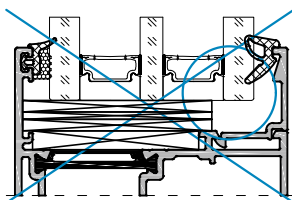
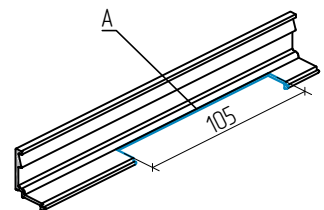

ALT SL160 series door unit installation in facade using AYPCLSL160.0501 adapter profile.

Infill unit thickness	Frame profile	Min. mullion profile	Min. transom profile	Auxiliary profile	Self-tapping screw			
					on mullion, step 600 mm	on transom, step 600 mm	on mullion, step 600 mm	
A	B	C	D	E	F	G	H	I
28 mm	AYPC SL160.0101, AYPC SL160.0102, AYPC SL160.0103	AYPC F50.0105	AYPC F50.0208	-	4.8x60-A2 DIN7982	4.8x60-A2 DIN7982	-	-
30 mm				-	4.8x60-A2 DIN7982	4.8x60-A2 DIN7982	-	-
32 mm				-	4.8x60-A2 DIN7982	4.8x60-A2 DIN7982	-	-
34 mm				AYPC F50.0701	4.8x70-A2 DIN7982	4.8x70-A2 DIN7982	3.9x16-A2 DIN7982	3.9x16-A2 DIN7982
36 mm				AYPC F50.0701	4.8x70-A2 DIN7982	4.8x70-A2 DIN7982	3.9x16-A2 DIN7982	3.9x16-A2 DIN7982
38 mm				AYPC F50.0701	4.8x70-A2 DIN7982	4.8x70-A2 DIN7982	3.9x16-A2 DIN7982	3.9x16-A2 DIN7982
40 mm				AYPC F50.0702	4.8x70-A2 DIN7982	4.8x70-A2 DIN7982	3.9x16-A2 DIN7982	3.9x16-A2 DIN7982
42 mm				AYPC F50.0702	4.8x70-A2 DIN7982	4.8x70-A2 DIN7982	3.9x16-A2 DIN7982	3.9x16-A2 DIN7982
44 mm				AYPC F50.0702	4.8x70-A2 DIN7982	4.8x70-A2 DIN7982	3.9x16-A2 DIN7982	3.9x16-A2 DIN7982
46 mm				AYPC F50.0703	4.8x80-A2 DIN7982	4.8x80-A2 DIN7982	3.9x16-A2 DIN7982	3.9x16-A2 DIN7982
48 mm	AYPC F50.0703	4.8x80-A2 DIN7982	4.8x80-A2 DIN7982	3.9x16-A2 DIN7982	3.9x16-A2 DIN7982			
50 mm	AYPC F50.0703	4.8x80-A2 DIN7982	4.8x80-A2 DIN7982	3.9x16-A2 DIN7982	3.9x16-A2 DIN7982			
52 mm	AYPC F50.0702+AYPC F50.0702	4.8x80-A2 DIN7982	4.8x80-A2 DIN7982	3.9x32-A2 DIN7982	3.9x32-A2 DIN7982			
54 mm	AYPC F50.0702+AYPC F50.0702	4.8x80-A2 DIN7982	4.8x80-A2 DIN7982	3.9x32-A2 DIN7982	3.9x32-A2 DIN7982			

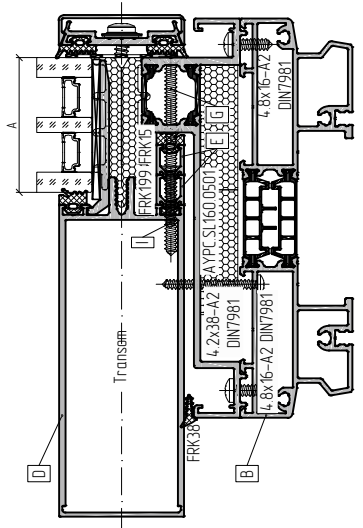
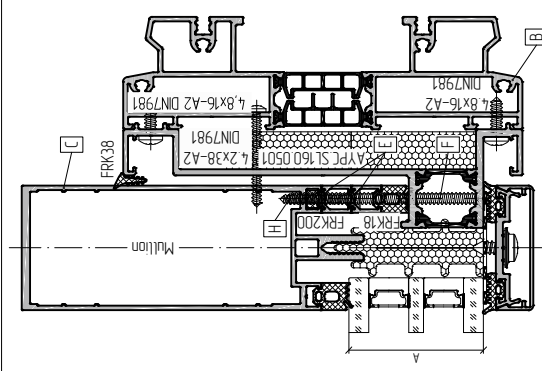

Data for AYPC F50.0701, AYPC F50.0703 and AYPC F50.0703 auxiliary profiles is provided in ALT F50 technical manual.

ALT SL160 series door unit installation in facade using AYPCLSL160.0501 adapter profile		The 2 level transom, overlap milling							
Infill unit thickness	Frame profile	Min. mullion profile	Min. transom profile	Auxiliary profile	Self-tapping screw				
					on mullion, step 600 mm	on transom, step 600 mm	on transom, step 600 mm		
A	B	C	D	E	F	G	H	I	
28 mm	AYPC SL160.0101, AYPC SL160.0102, AYPC SL160.0103	AYPC F50.0105	AYPC F50.0235	-	4.8x60-A2 DIN7982	4.8x60-A2 DIN7982	4.8x60-A2 DIN7982	4.8x60-A2 DIN7982	
30 mm				-	4.8x60-A2 DIN7982	4.8x60-A2 DIN7982	4.8x60-A2 DIN7982	4.8x60-A2 DIN7982	4.8x60-A2 DIN7982
32 mm				-	4.8x60-A2 DIN7982	4.8x60-A2 DIN7982	4.8x60-A2 DIN7982	4.8x60-A2 DIN7982	4.8x60-A2 DIN7982
34 mm				-	4.8x70-A2 DIN7982	4.8x70-A2 DIN7982	4.8x70-A2 DIN7982	4.8x70-A2 DIN7982	4.8x70-A2 DIN7982
36 mm				-	4.8x70-A2 DIN7982	4.8x70-A2 DIN7982	4.8x70-A2 DIN7982	4.8x70-A2 DIN7982	4.8x70-A2 DIN7982
38 mm				-	4.8x70-A2 DIN7982	4.8x70-A2 DIN7982	4.8x70-A2 DIN7982	4.8x70-A2 DIN7982	4.8x70-A2 DIN7982
40 mm				-	4.8x70-A2 DIN7982	4.8x70-A2 DIN7982	4.8x70-A2 DIN7982	4.8x70-A2 DIN7982	4.8x70-A2 DIN7982
42 mm				-	4.8x70-A2 DIN7982	4.8x70-A2 DIN7982	4.8x70-A2 DIN7982	4.8x70-A2 DIN7982	4.8x70-A2 DIN7982
44 mm				-	4.8x70-A2 DIN7982	4.8x70-A2 DIN7982	4.8x70-A2 DIN7982	4.8x70-A2 DIN7982	4.8x70-A2 DIN7982
46 mm				-	4.8x80-A2 DIN7982	4.8x80-A2 DIN7982	4.8x80-A2 DIN7982	4.8x80-A2 DIN7982	4.8x80-A2 DIN7982
48 mm	-	4.8x80-A2 DIN7982	4.8x80-A2 DIN7982	4.8x80-A2 DIN7982	4.8x80-A2 DIN7982	4.8x80-A2 DIN7982			
50 mm	-	4.8x80-A2 DIN7982	4.8x80-A2 DIN7982	4.8x80-A2 DIN7982	4.8x80-A2 DIN7982	4.8x80-A2 DIN7982			
52 mm	-	4.8x80-A2 DIN7982	4.8x80-A2 DIN7982	4.8x80-A2 DIN7982	4.8x80-A2 DIN7982	4.8x80-A2 DIN7982			
54 mm	-	4.8x80-A2 DIN7982	4.8x80-A2 DIN7982	4.8x80-A2 DIN7982	4.8x80-A2 DIN7982	4.8x80-A2 DIN7982			

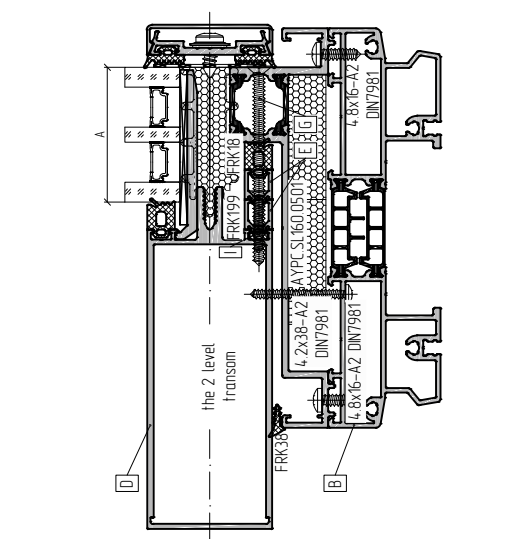

Data for AYPCLSL160.0101, AYPCLSL160.0102, AYPCLSL160.0103 auxiliary profiles is provided in ALT F50 technical manual.





ALUTECH ALT SL160

Lifting and sliding constructions

01

02

03

04

05

06

07

08

09

10

SECTIONS AND JUNCTIONS

Typical door configurations. Exterior view

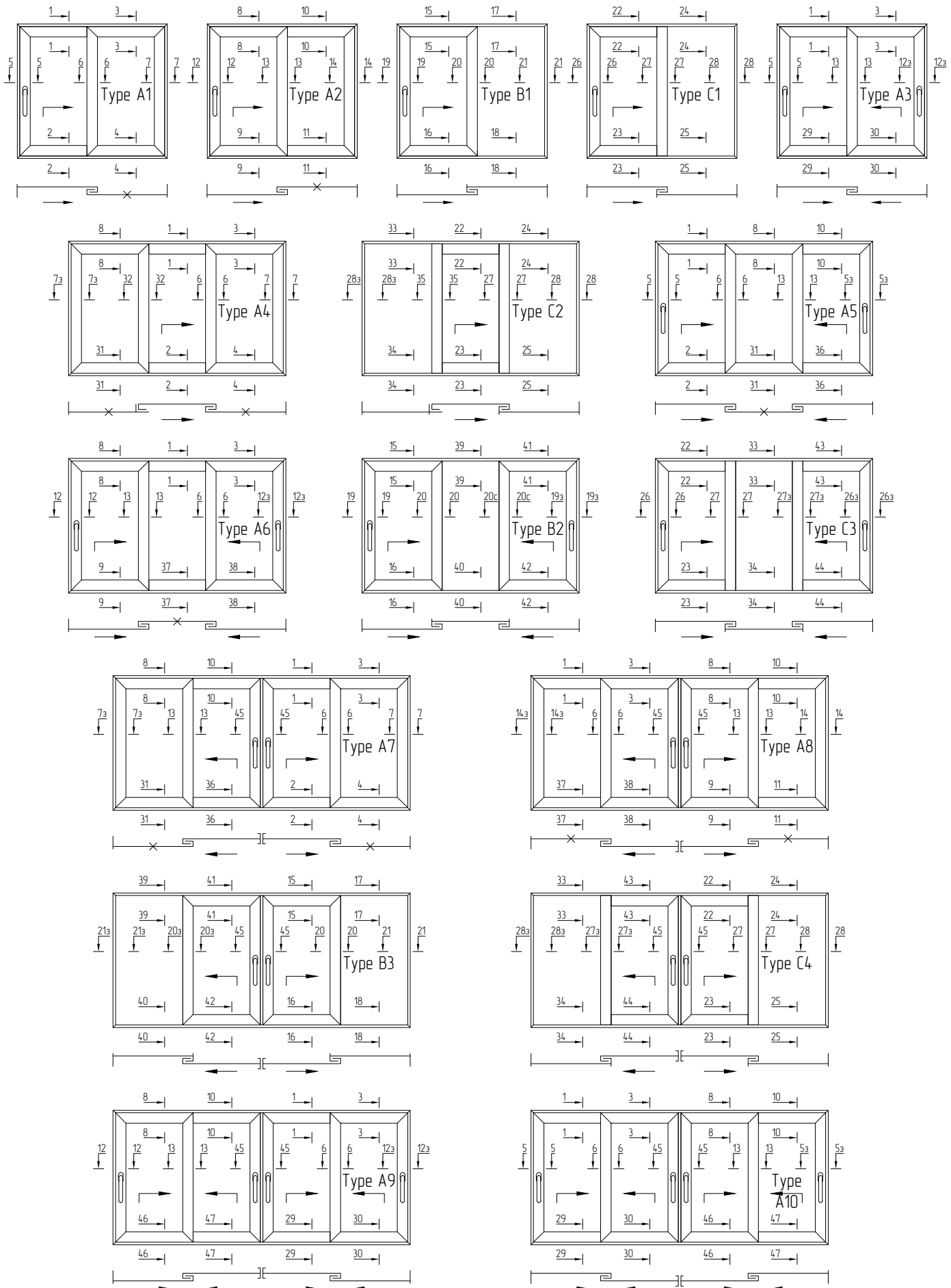

01

02

03

04

05

06

07

08

09

10

Typical door configurations. Exterior view

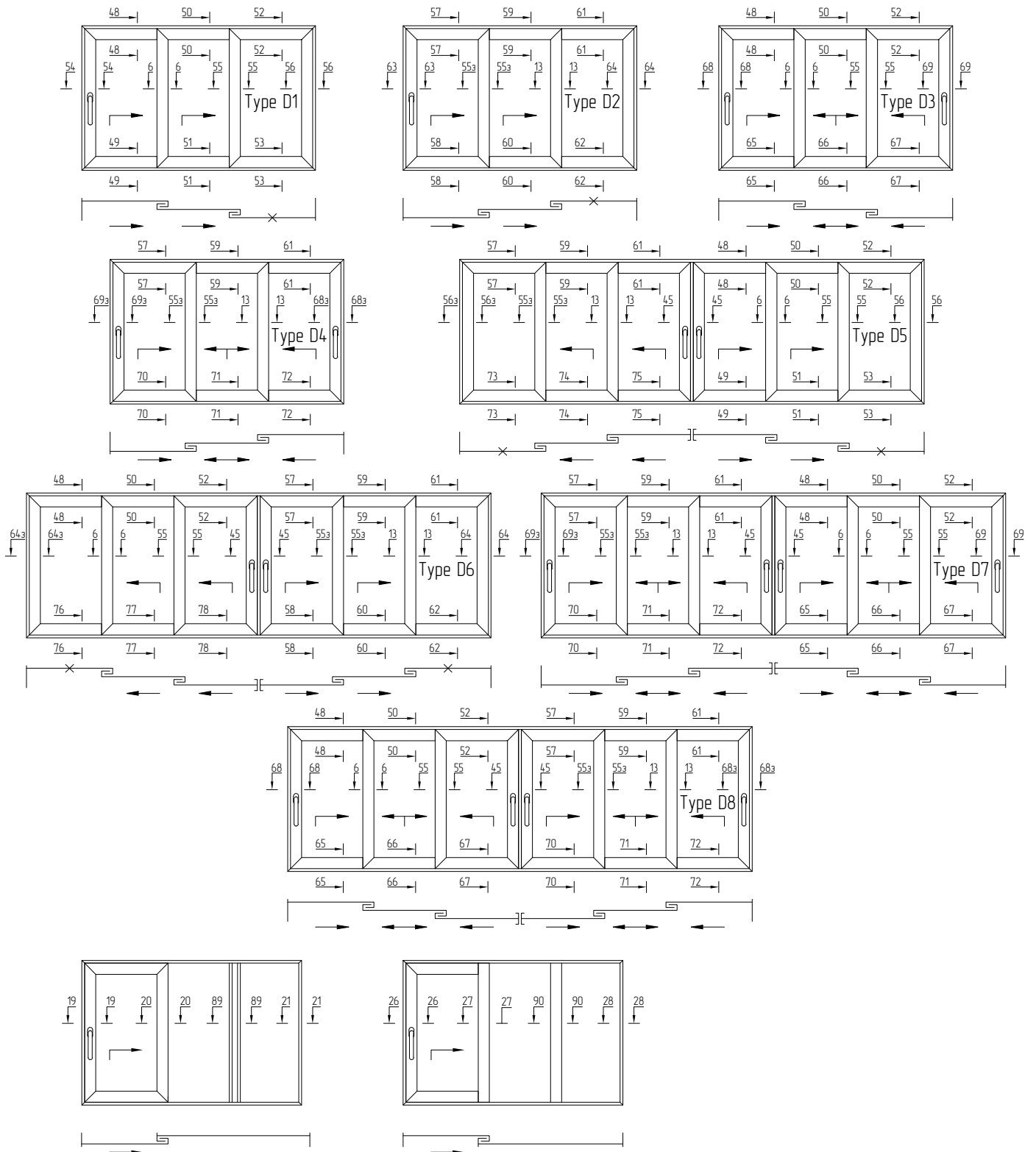

Sections marked "XX₃" are specular reflection of sections "XX".
 Type A - doors with AYPC.SL160.0101 frame
 Type B - doors with AYPC.SL160.0102 frame.
 Type C - doors with AYPC.SL160.0103 frame.
 Type D - doors with AYPC.SL160.0104 frame.

Typical door configurations. Exterior view

Section	Page	Section	Page	Section	Page	Section	Page	Section	Page	Section	Page
1-1	06.08	16-16	06.15	31-31	06.22	46-46	06.29	61-61	06.36	76-76	06.44
2-2	06.08	17-17	06.16	32-32	06.22	47-47	06.29	62-62	06.37	77-77	06.44
3-3	06.09	18-18	06.16	33-33	06.23	48-48	06.30	63-63	06.37	78-78	06.45
4-4	06.09	19-19	06.16	34-34	06.23	49-49	06.30	64-64	06.38	79-79	06.45
5-5	06.10	20-20	06.17	35-35	06.23	50-50	06.31	65-65	06.38	80-80	06.46
6-6	06.10	21-21	06.17	36-36	06.24	51-51	06.31	66-66	06.39	81-81	06.46
7-7	06.11	22-22	06.18	37-37	06.24	52-52	06.32	67-67	06.39	82-82	06.47
8-8	06.11	23-23	06.18	38-38	06.25	53-53	06.32	68-68	06.40	83-83	06.47
9-9	06.12	24-24	06.19	39-39	06.25	54-54	06.33	69-69	06.40	84-84	06.48
10-10	06.12	25-25	06.19	40-40	06.26	55-55	06.33	70-70	06.41	85-85	06.48
11-11	06.13	26-26	06.19	41-41	06.26	56-56	06.34	71-71	06.41	86-86	06.49
12-12	06.13	27-27	06.20	42-42	06.27	57-57	06.34	72-72	06.42	87-87	06.49
13-13	06.14	28-28	06.20	43-43	06.27	58-58	06.35	73-73	06.42	88-88	06.50
14-14	06.14	29-29	06.21	44-44	06.28	59-59	06.35	74-74	06.43	89-89	06.50
15-15	06.15	30-30	06.21	45-45	06.28	60-60	06.36	75-75	06.43	90-90	06.50

AYPC.SL160.0101 + AYPC.SL160.0202. Variant 1

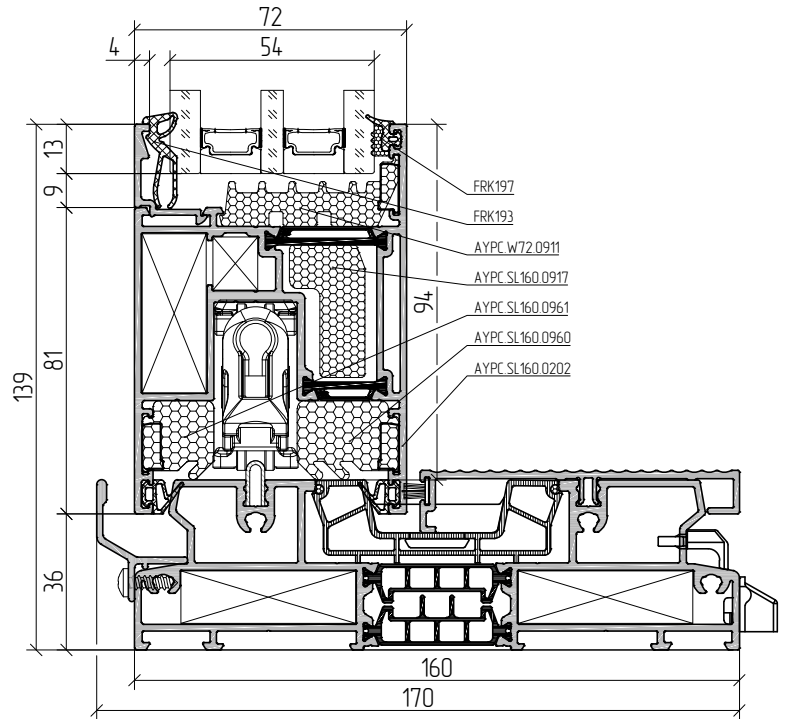
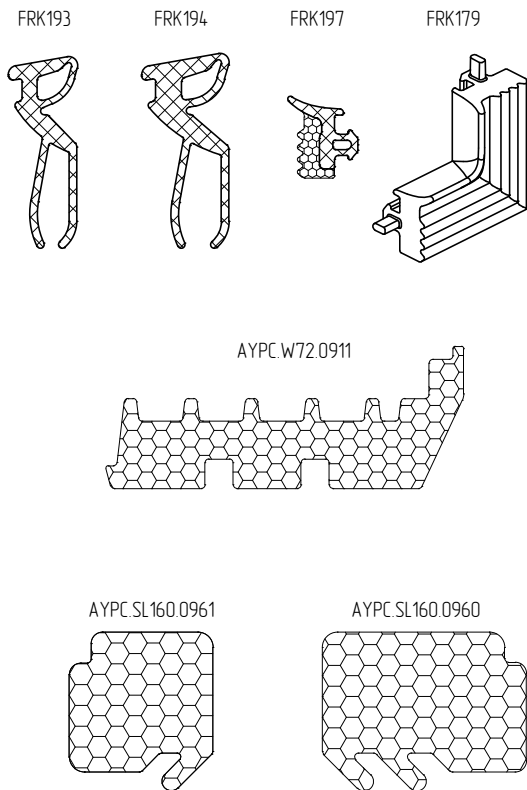

AYPC.SL160.0101 + AYPC.SL160.0202. Variant 2

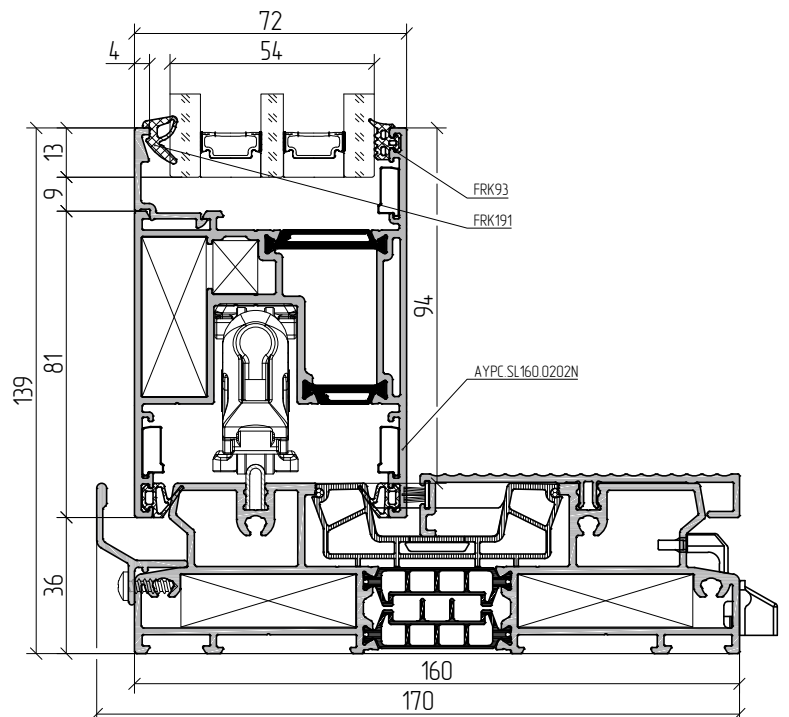

U-value calculation of AYPC.SL160 profiles in Flixo pro 7 (7.0.628.1) complex with foamed inserts in the glass unit fold area and inside of profile.

Variant 1. Junction: AYPC.SL160.0101 frame profile / AYPC.SL160.0202 leaf profile

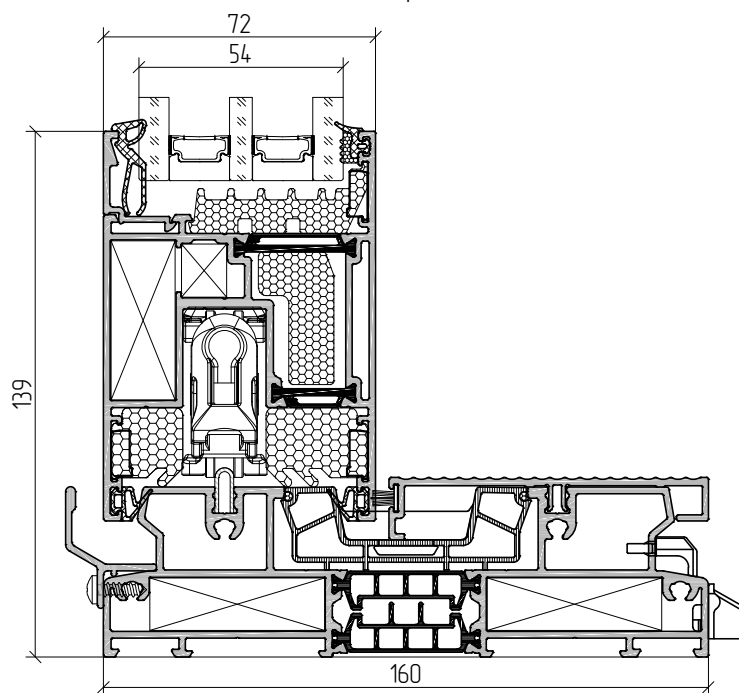

$$U_f = \frac{\frac{\Phi}{\Delta T} - U_p \cdot b_p}{b_f} = \frac{11.627}{30.000} - \frac{0.584 \cdot 0.190}{0.139} = 1.99 \frac{W}{m^2 \cdot K}$$

U-value calculation of AYPC.SL160 profiles in Flixo pro 7 (7.0.628.1) complex without foamed inserts in the glass unit fold area and inside of the profile.

Variant 2. Junction: AYPC.SL160.0101 frame profile / AYPC.SL160.0202N leaf profile

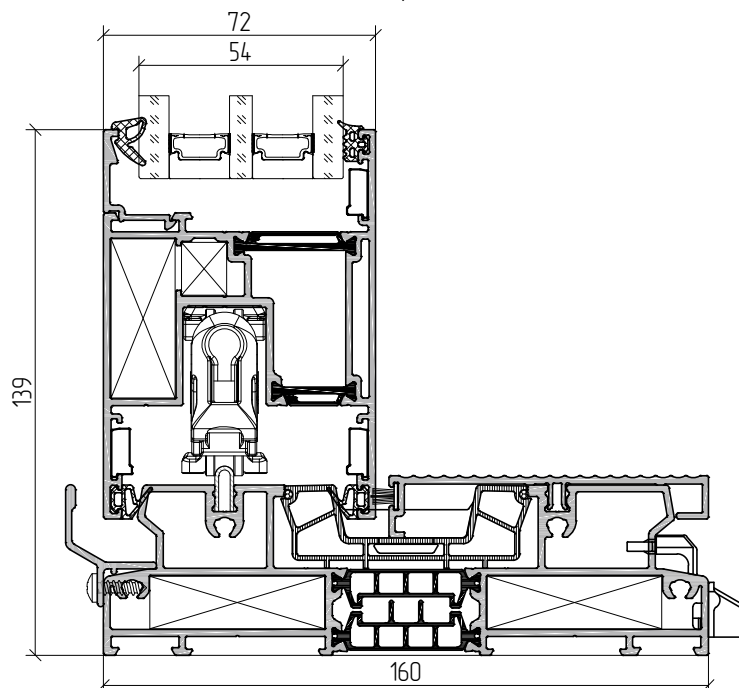

$$U_f = \frac{\frac{\Phi}{\Delta T} - U_p \cdot b_p}{b_f} = \frac{15.522}{30.000} - \frac{0.584 \cdot 0.190}{0.139} = 2.93 \frac{W}{m^2 \cdot K}$$

AYPC.SL160.0102 + AYPC.SL160.0202. Variant 1

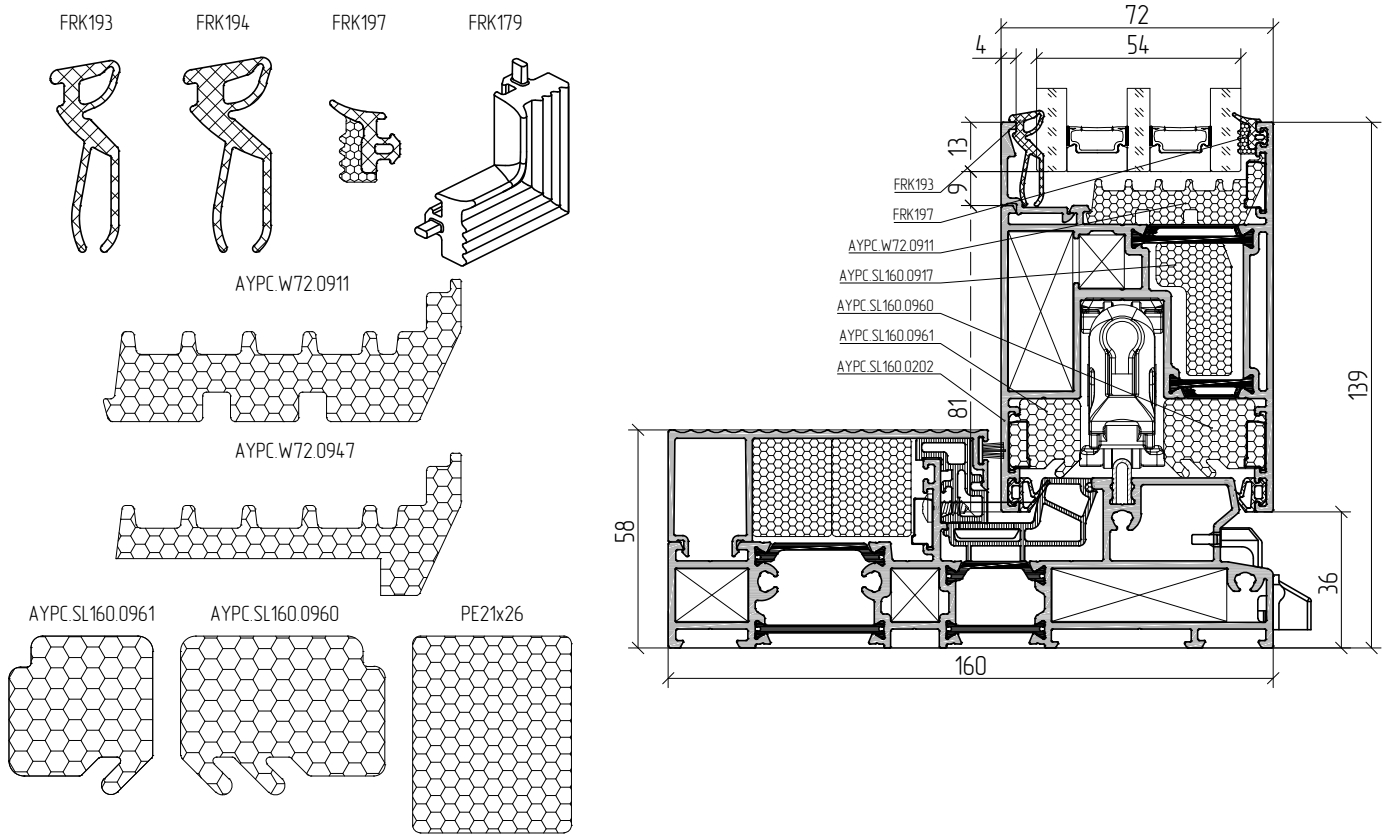

AYPC.SL160.0102 + AYPC.SL160.0202. Variant 2

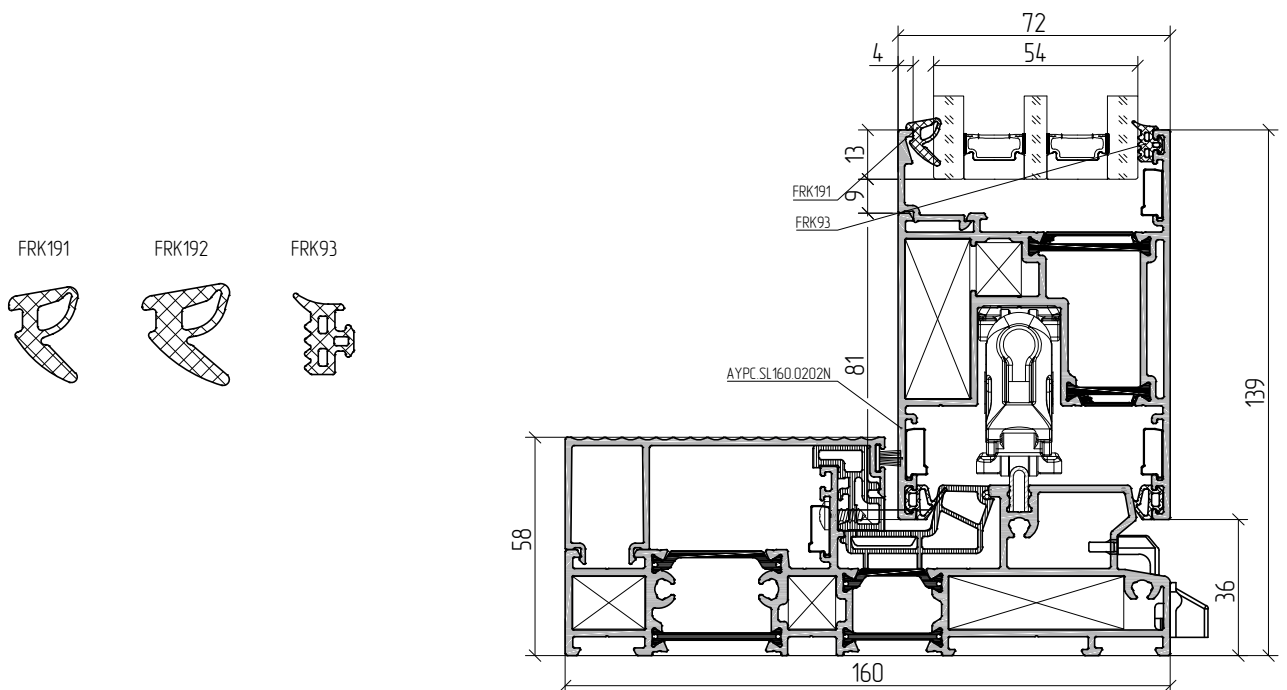

U-value calculation of AYPC.SL160 profiles in Flixa pro 7 (7.0.628.1) complex with foamed inserts in the glass unit fold area and inside of profile.

Variant 1. Junction: AYPC.SL160.0102 frame profile / AYPC.SL160.0202 leaf profile

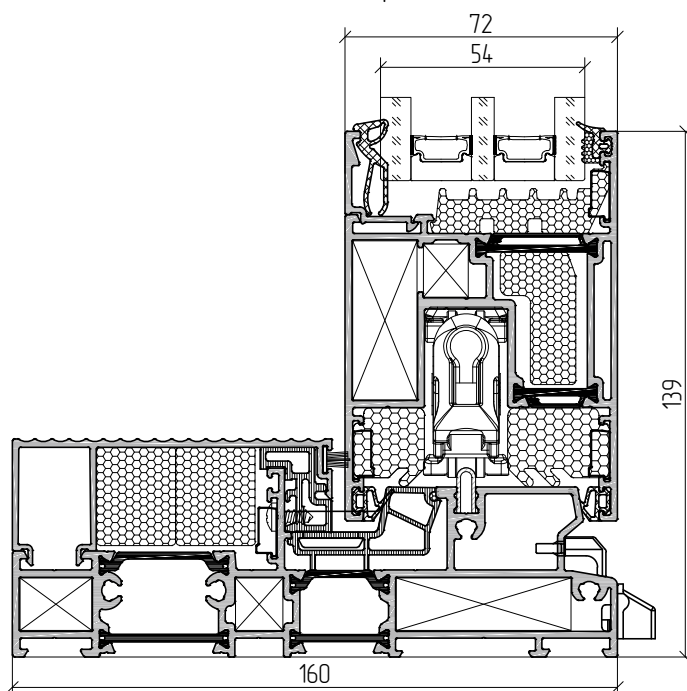

$$U_f = \frac{\frac{\Phi}{\Delta T} - U_p \cdot b_p}{b_f} = \frac{\frac{13.400}{30.000} - 0.584 \cdot 0.190}{0.139} = 2.42 \frac{W}{m^2 \cdot K}$$

U-value calculation of AYPC.SL160 profiles in Flixa pro 7 (7.0.628.1) complex without foamed inserts in the glass unit fold area and inside of profile.

Versin 2. Junction: AYPC.SL160.0102 frame profile / AYPC.SL160.0202N leaf profile

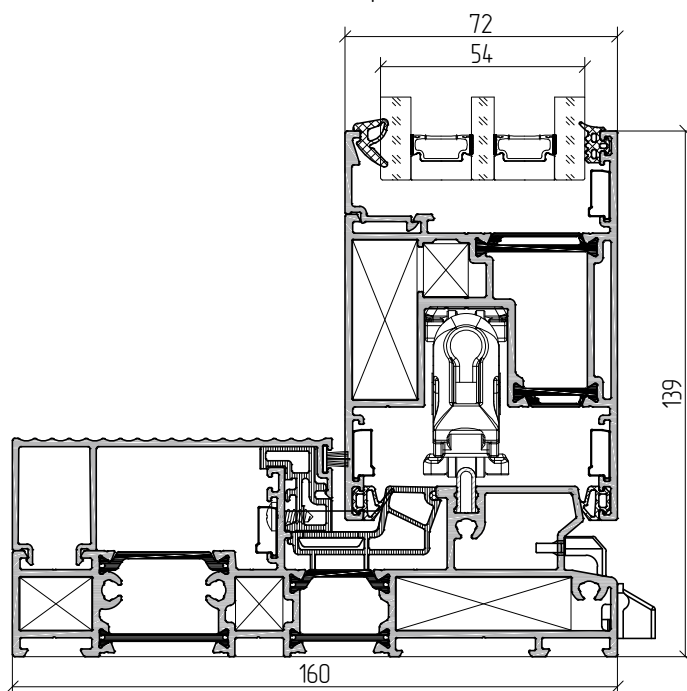

$$U_f = \frac{\frac{\Phi}{\Delta T} - U_p \cdot b_p}{b_f} = \frac{\frac{16.495}{30.000} - 0.584 \cdot 0.191}{0.139} = 3.18 \frac{W}{m^2 \cdot K}$$

Scale 1:2

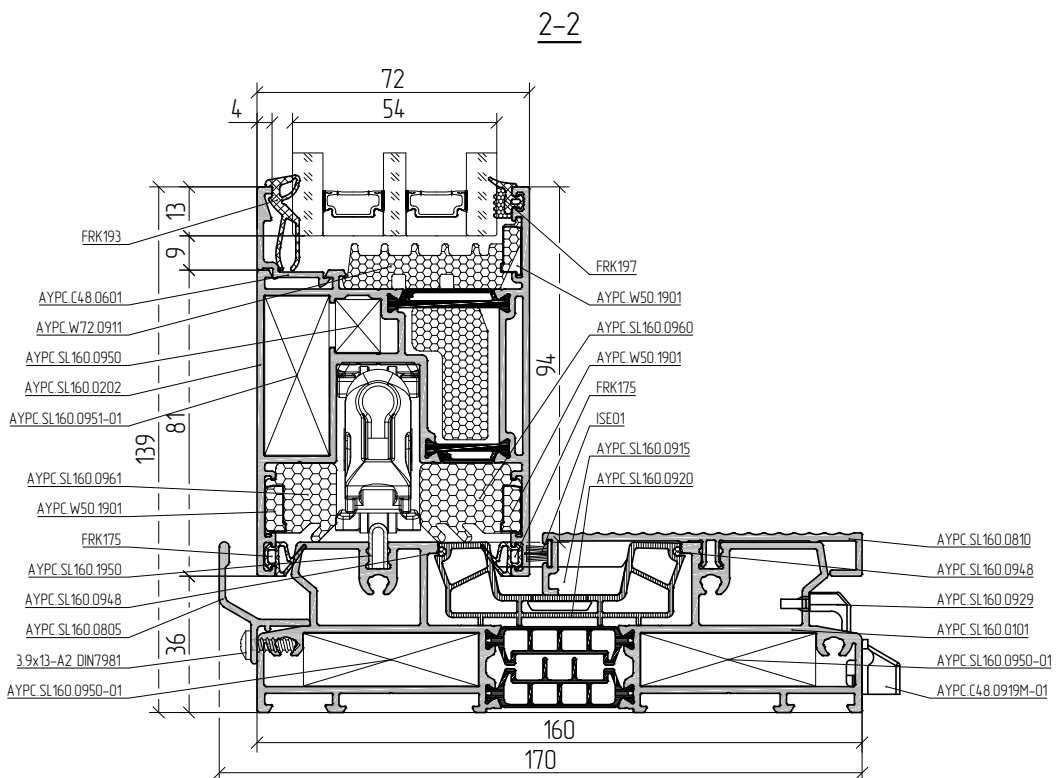
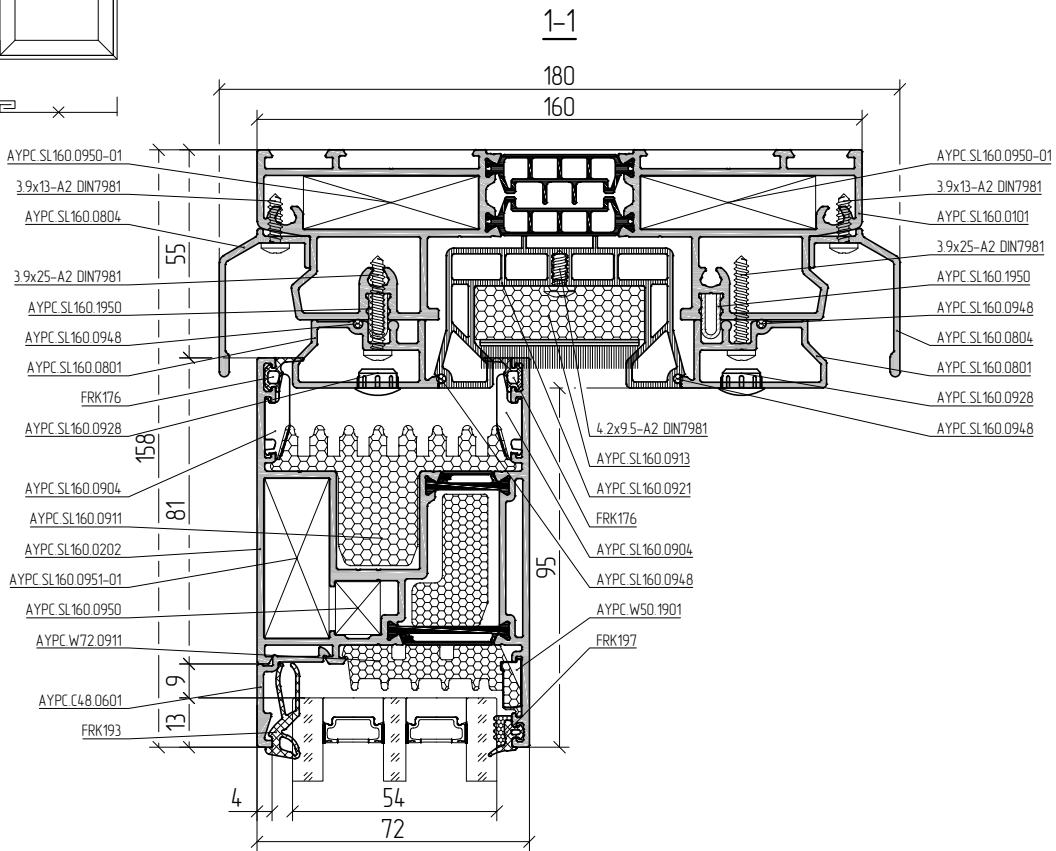
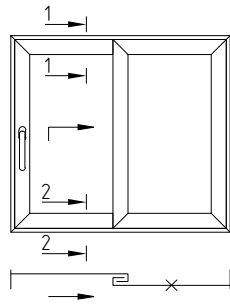

Scale 1:2

01

02

03

04

05

06

07

08

09

10

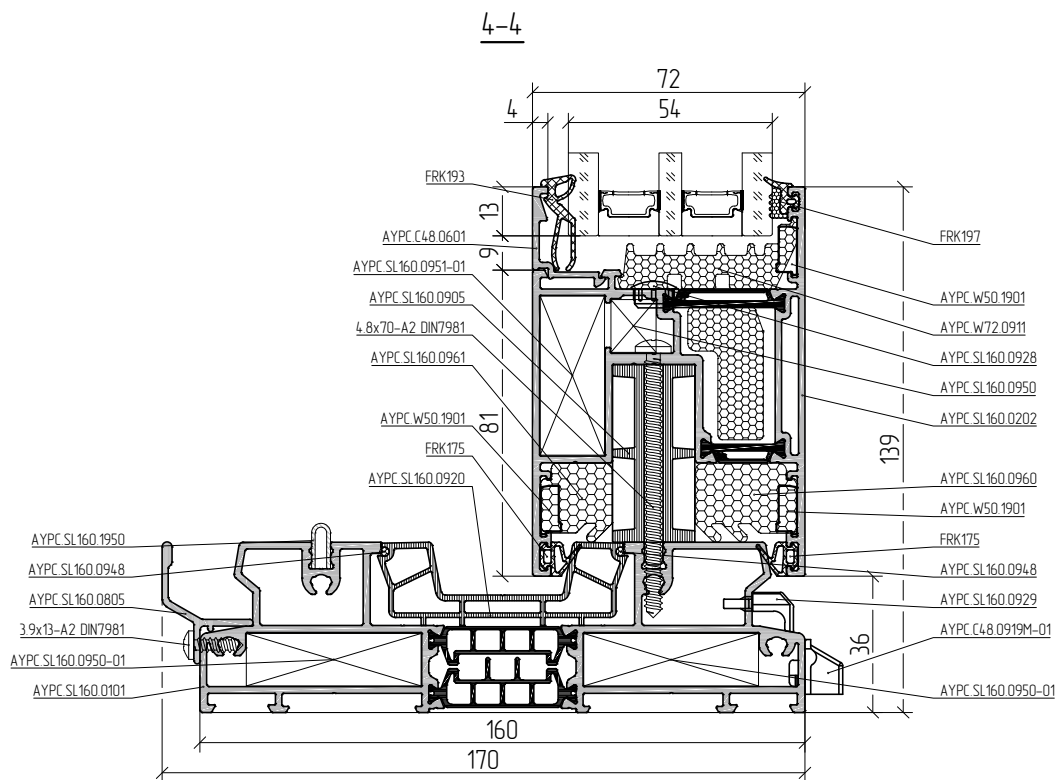
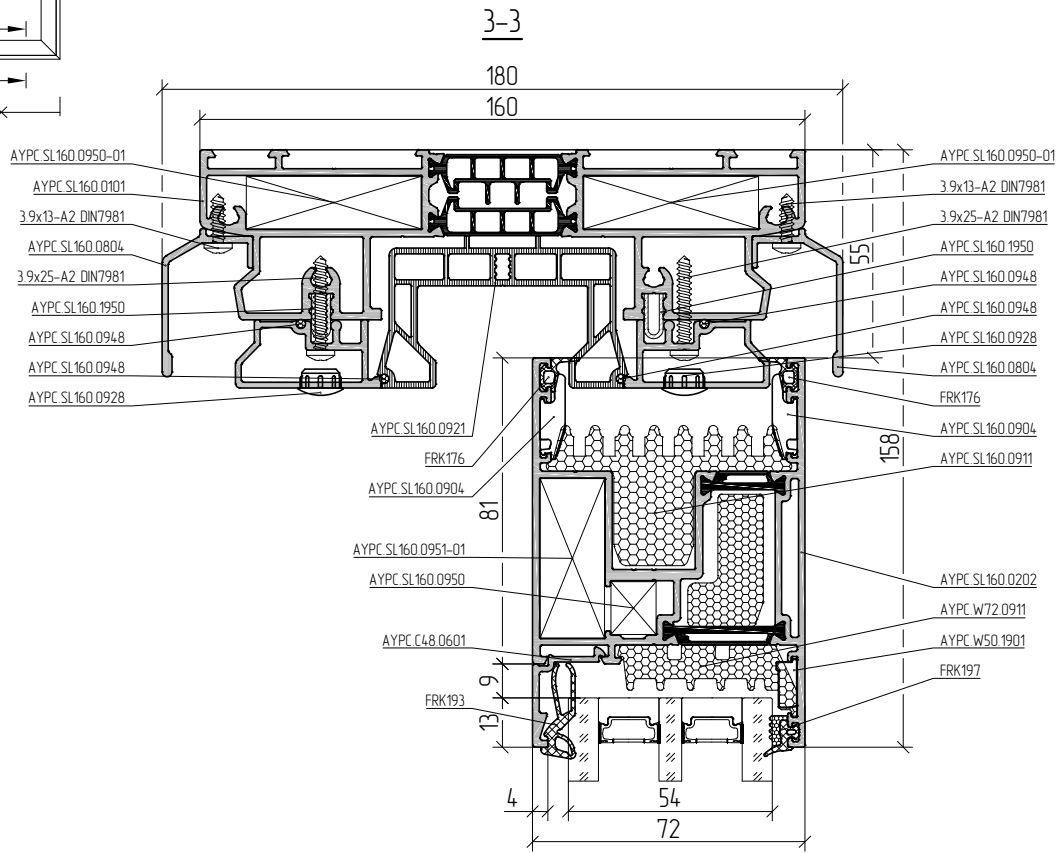
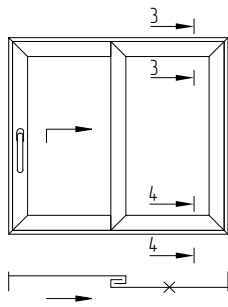

Scale 1:2

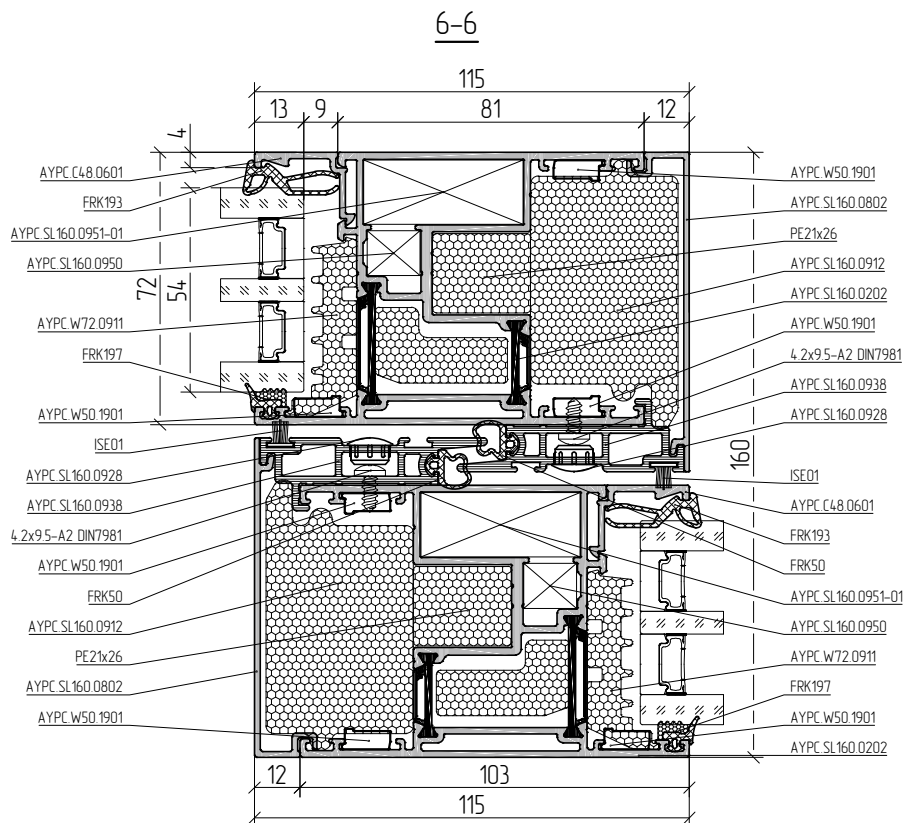
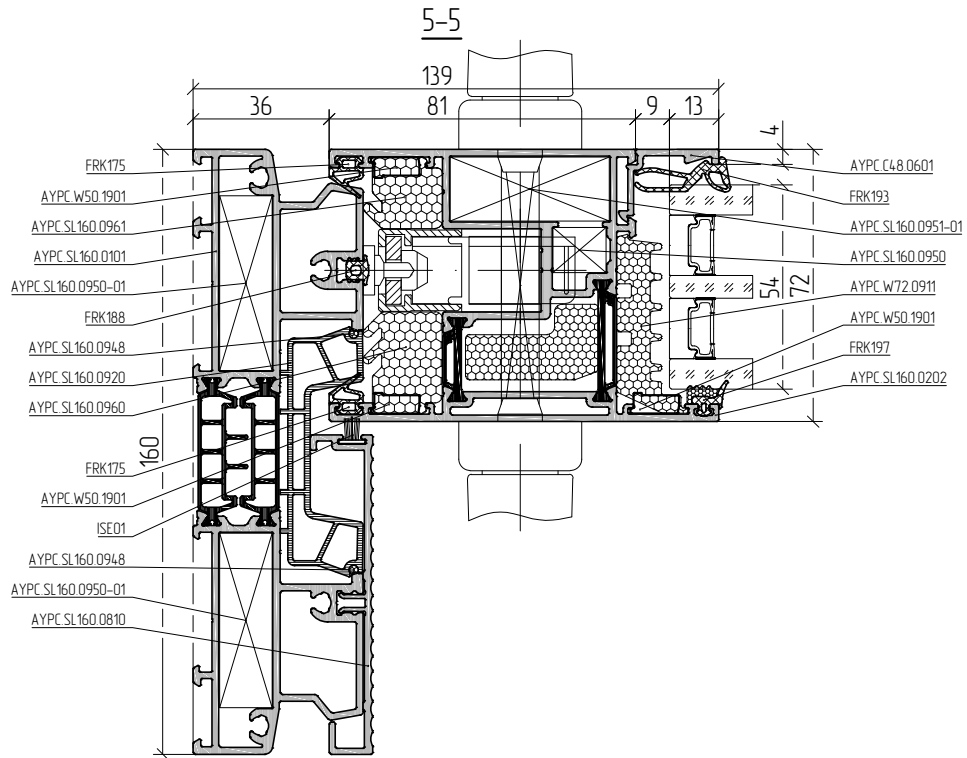
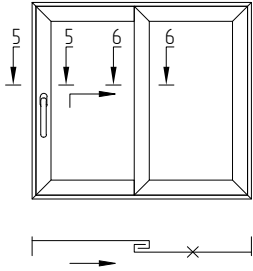

Scale 1:2

01

02

03

04

05

06

07

08

09

10

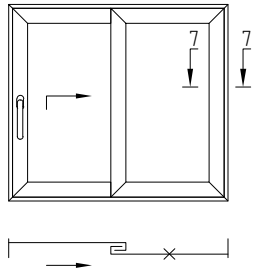

7-7

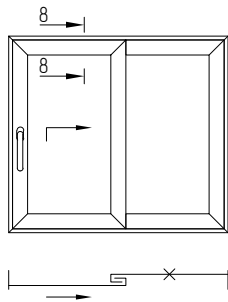
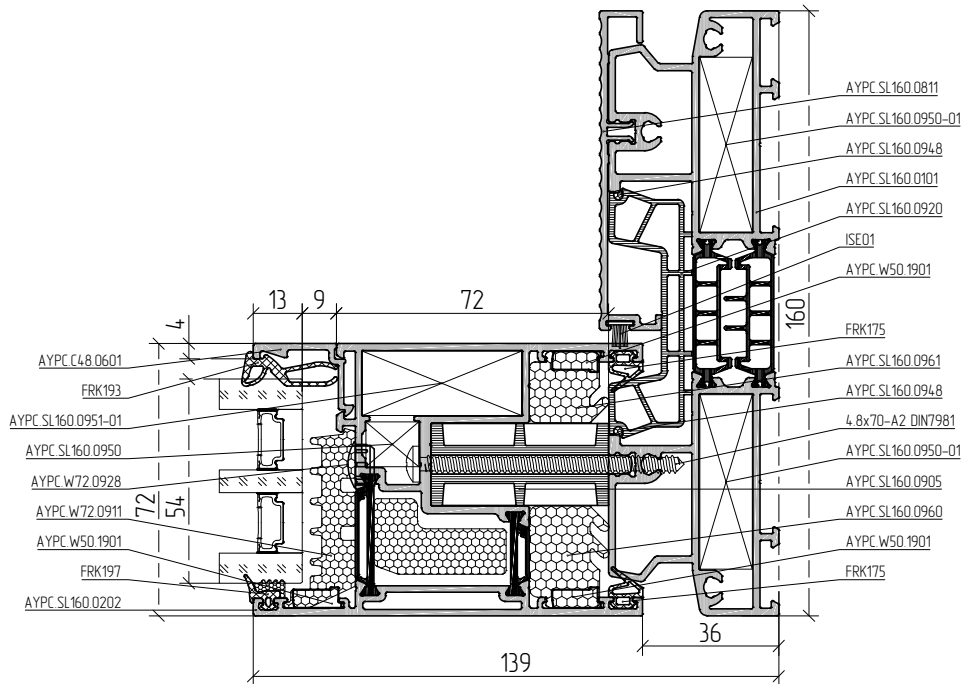

8-8

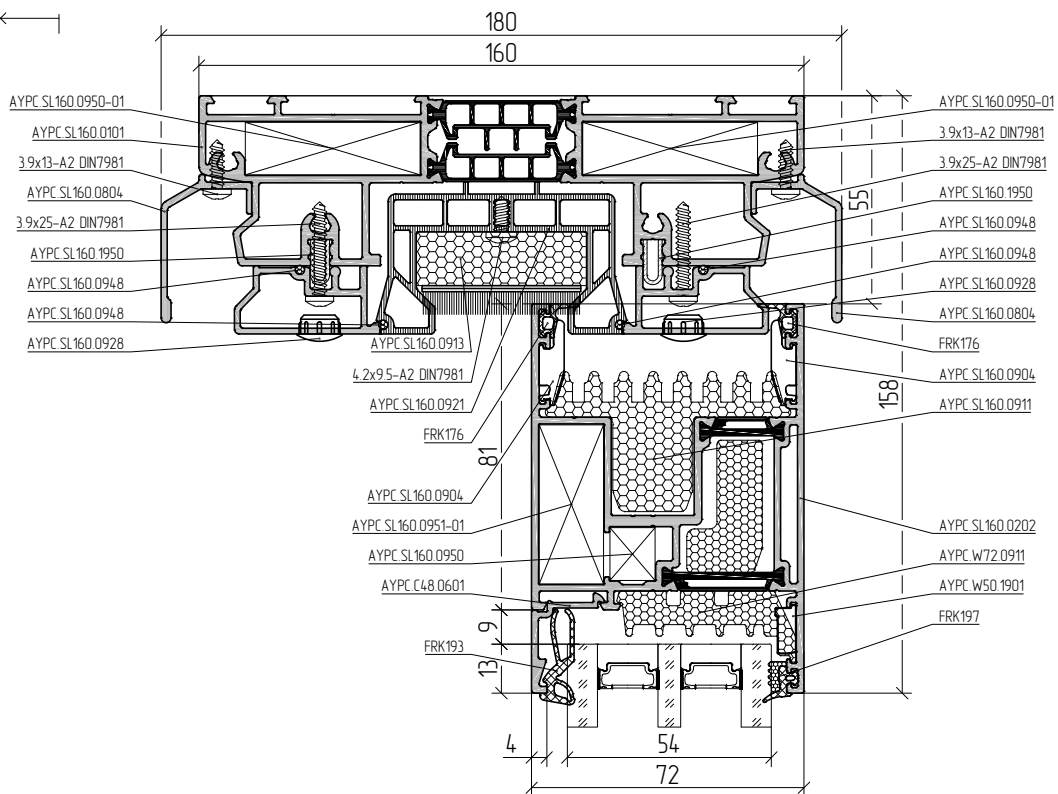

Scale 1:2

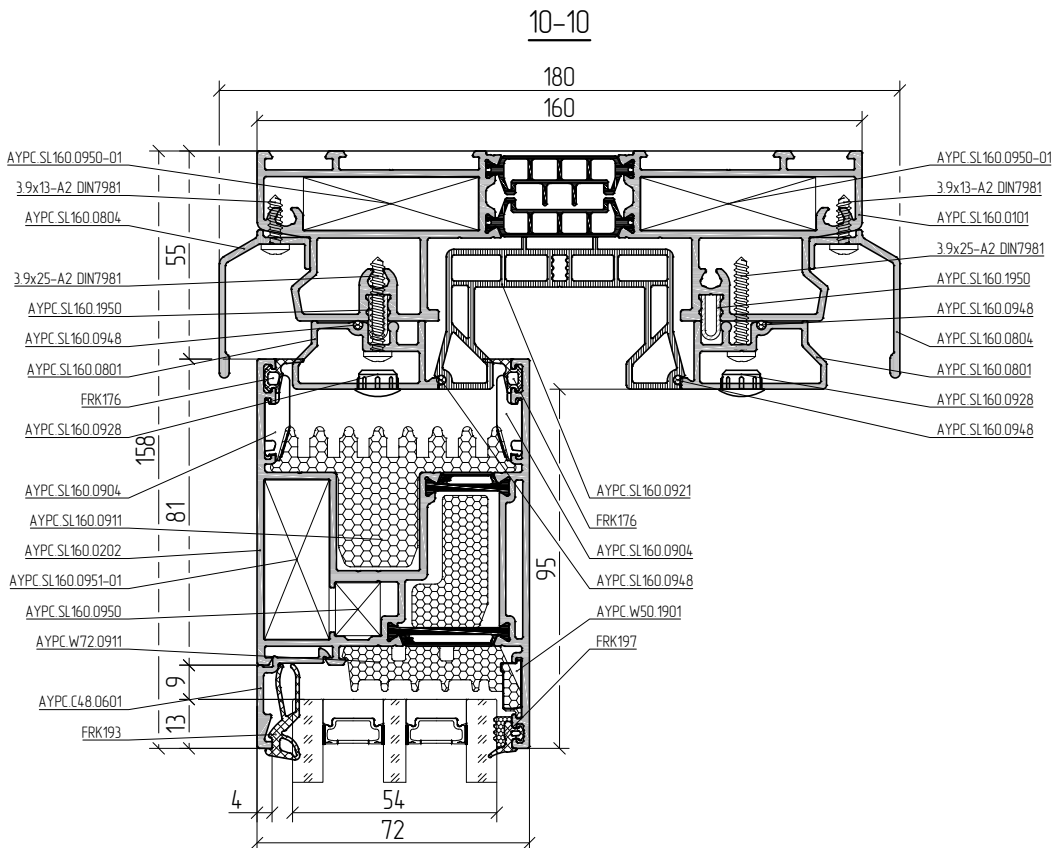
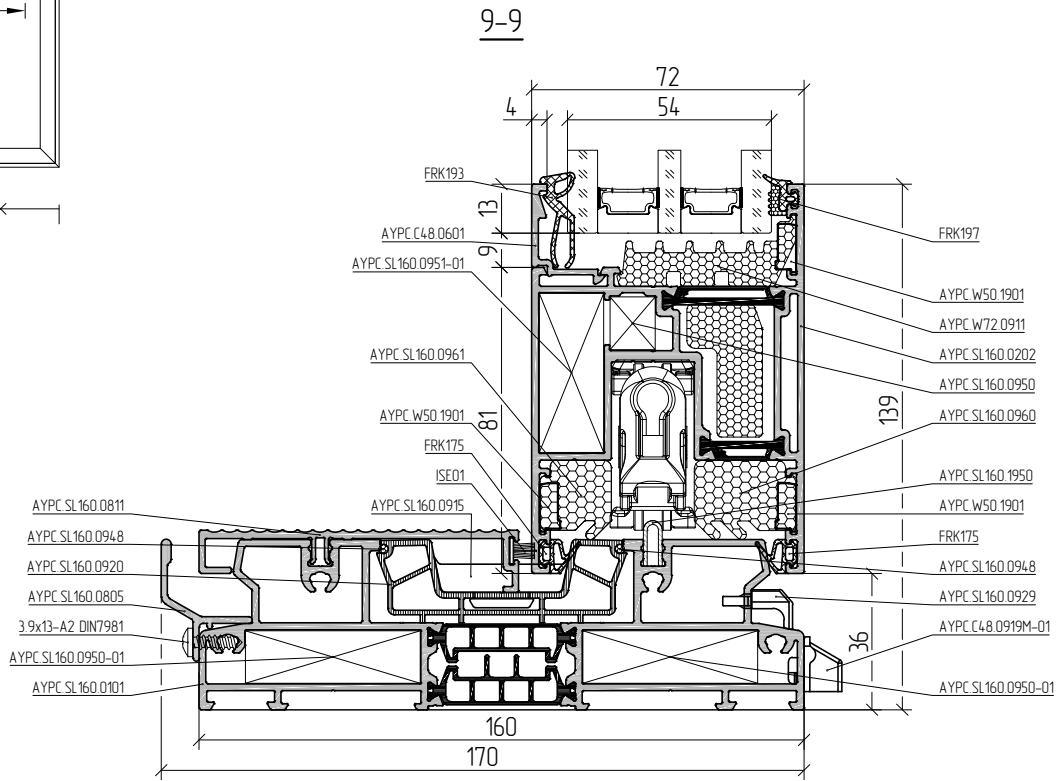
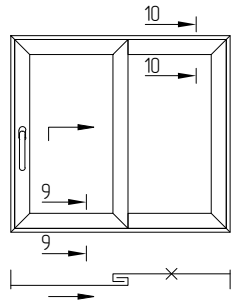

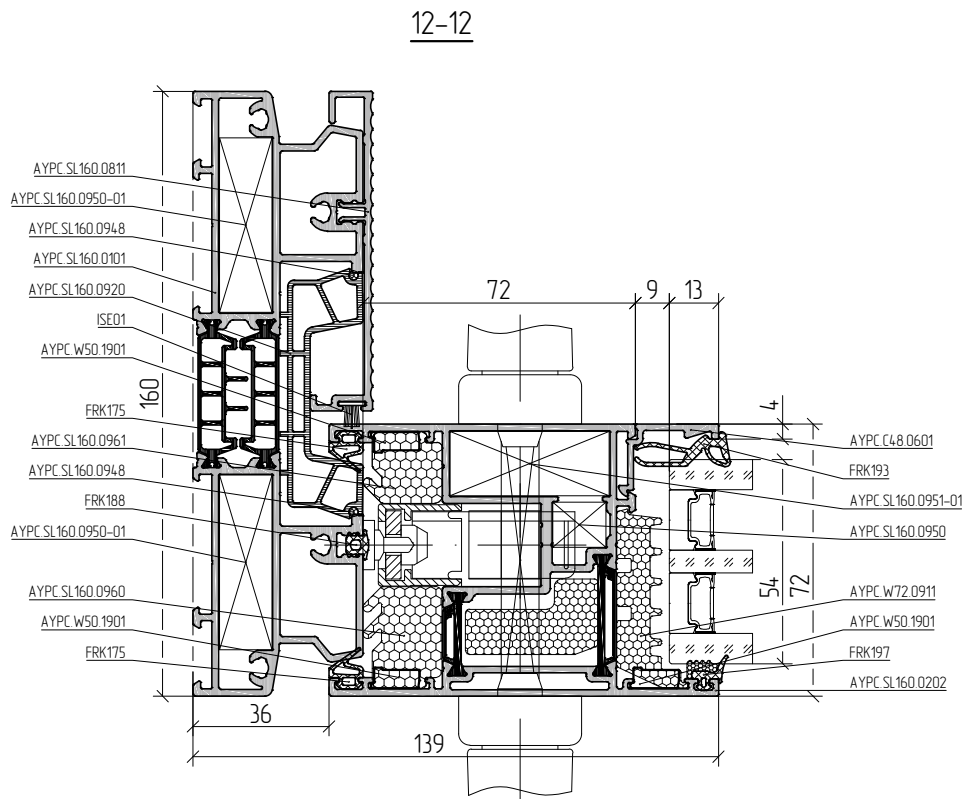
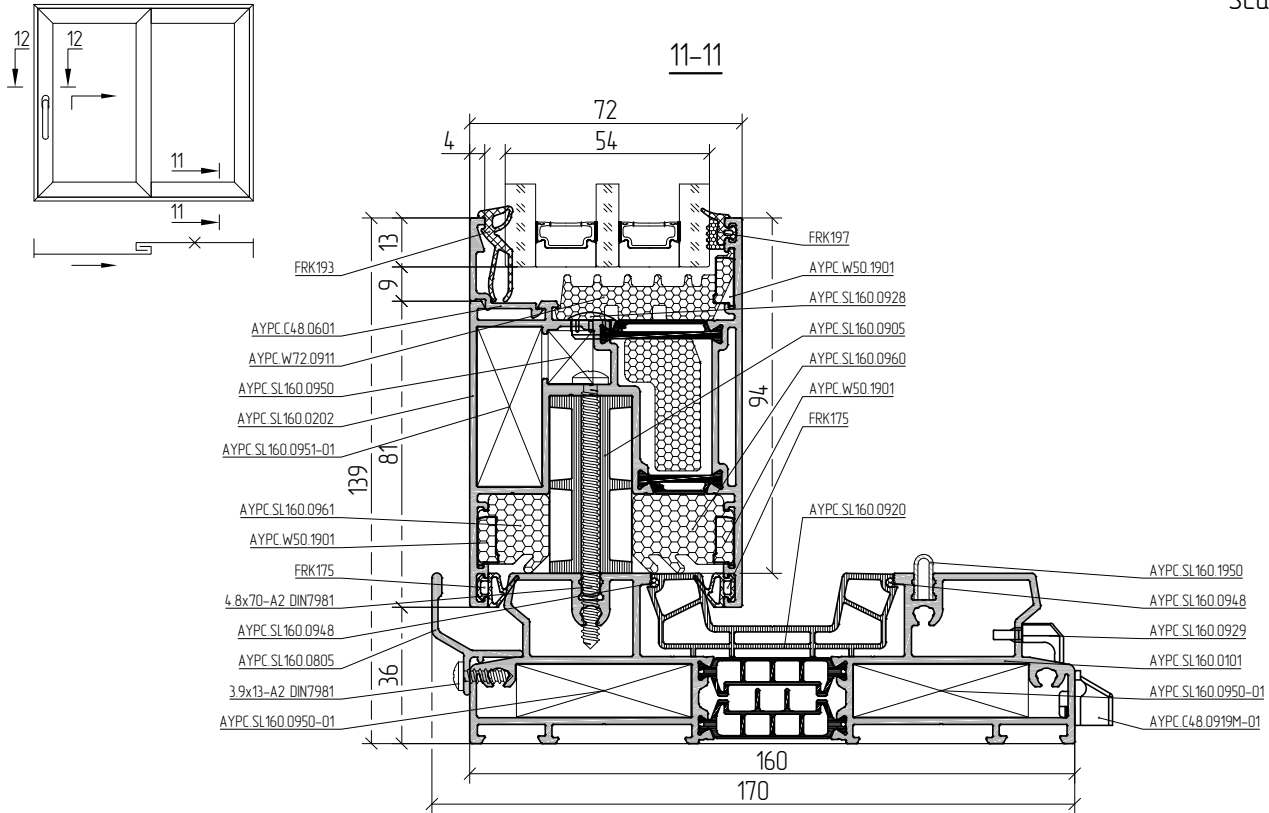

Scale 1:2

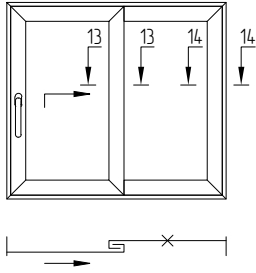

13-13

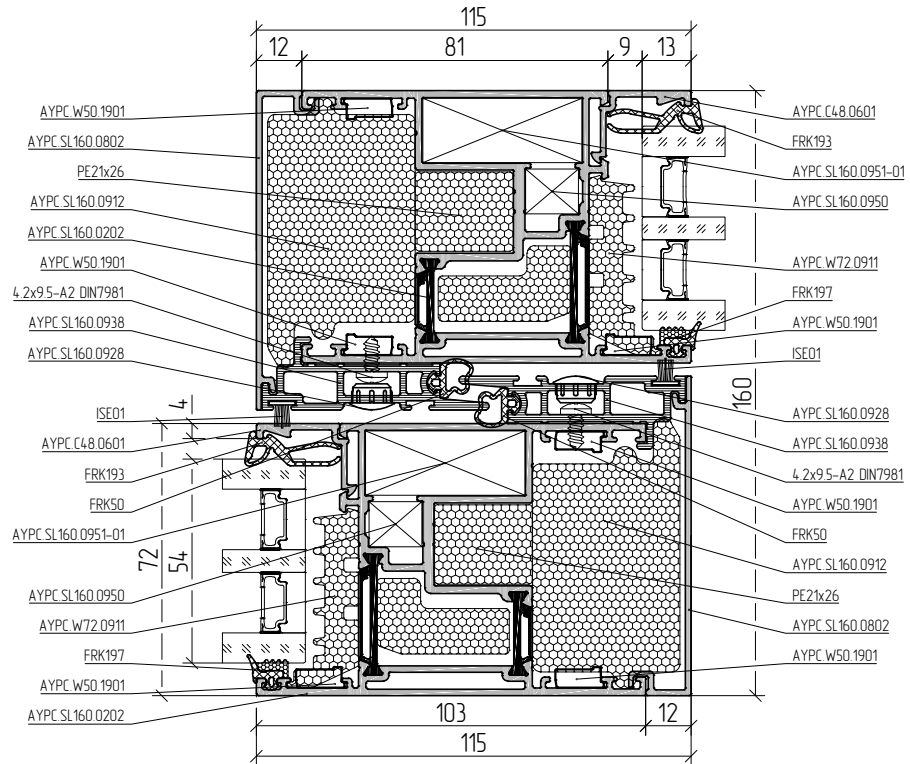

14-14

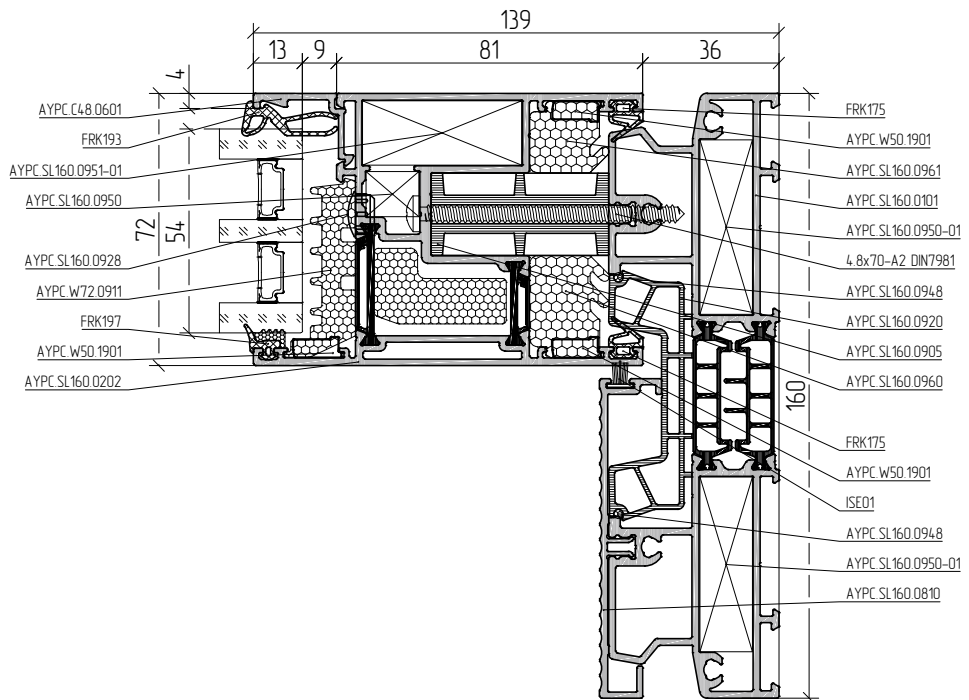

Scale 1:2

01

02

03

04

05

06

07

08

09

10

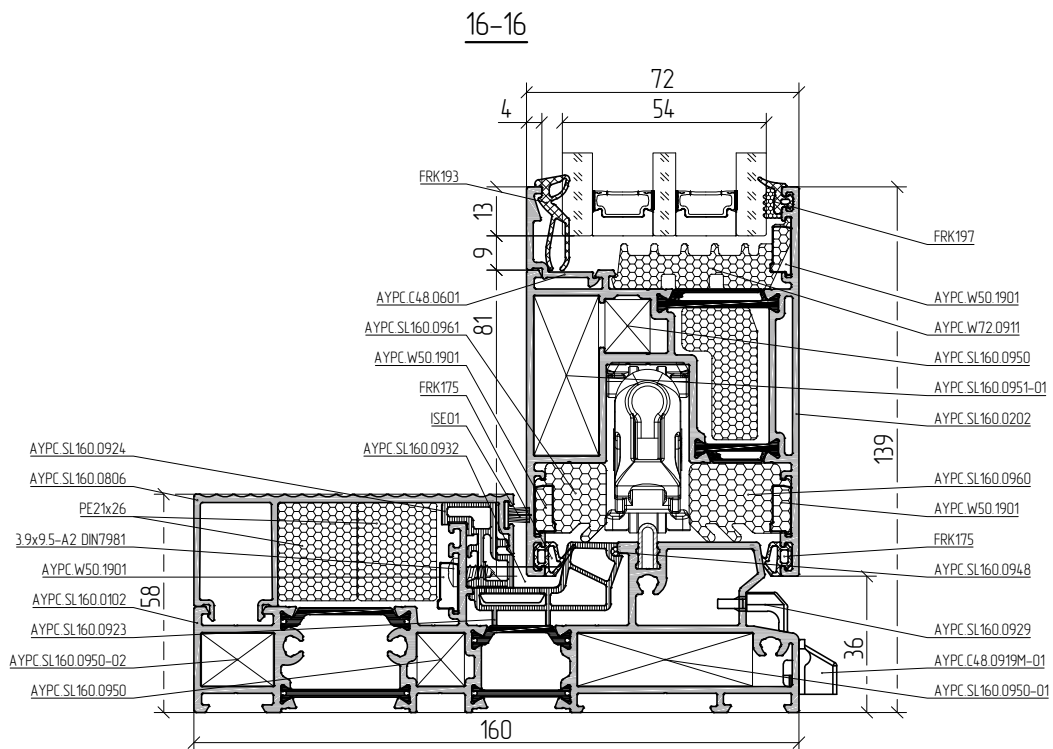
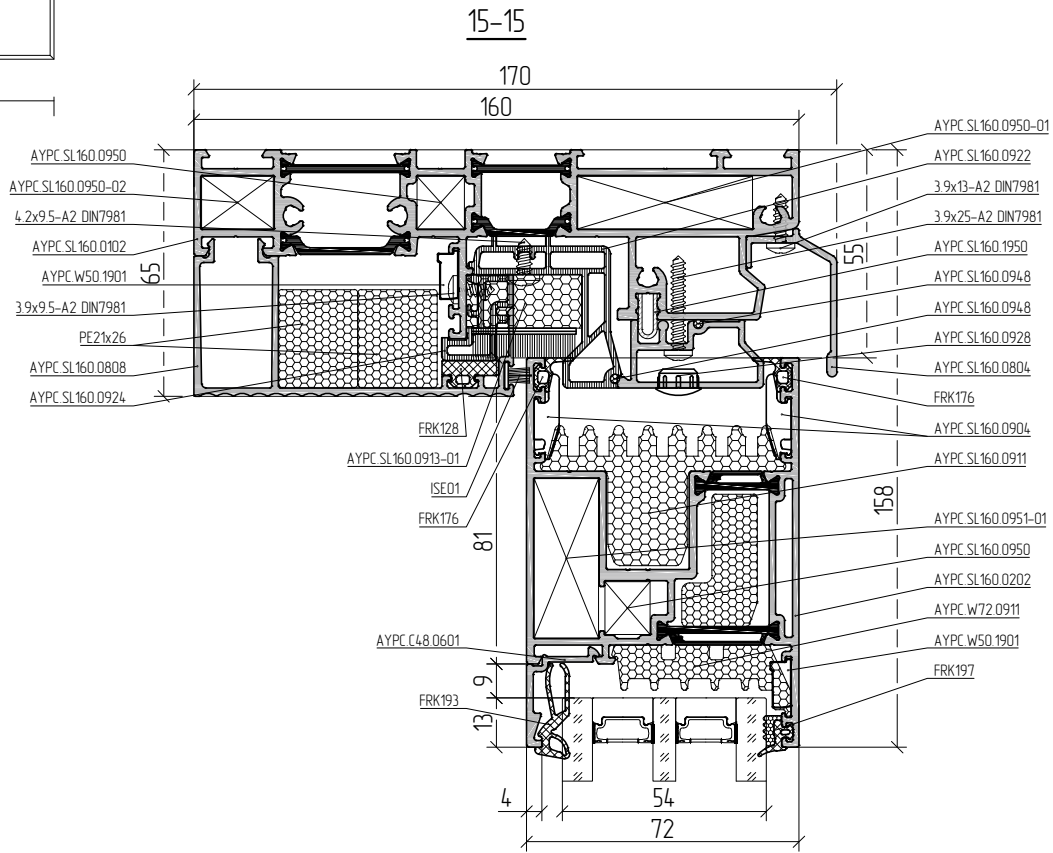
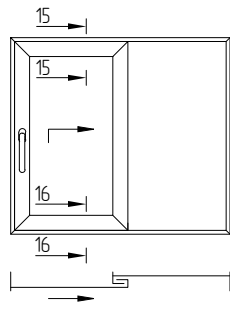

Scale 1:2

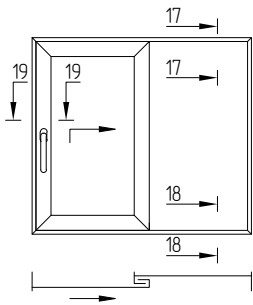

17-17

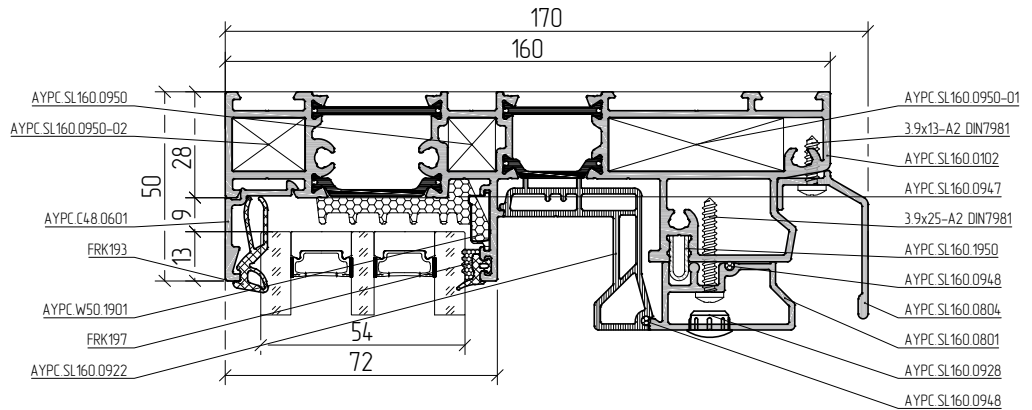

18-18

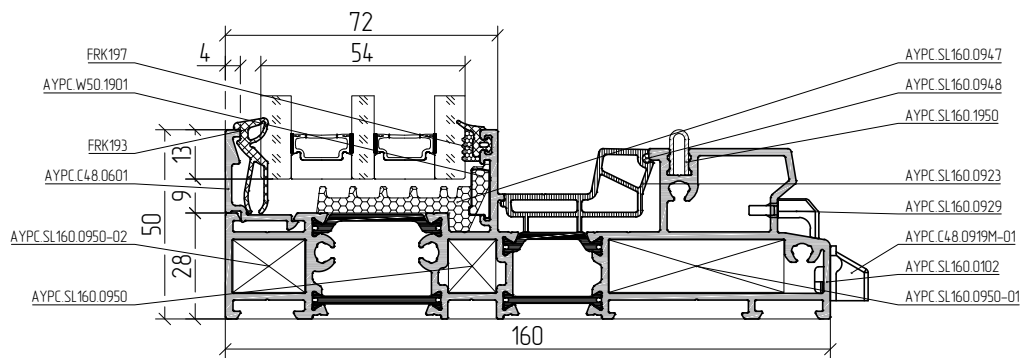

19-19

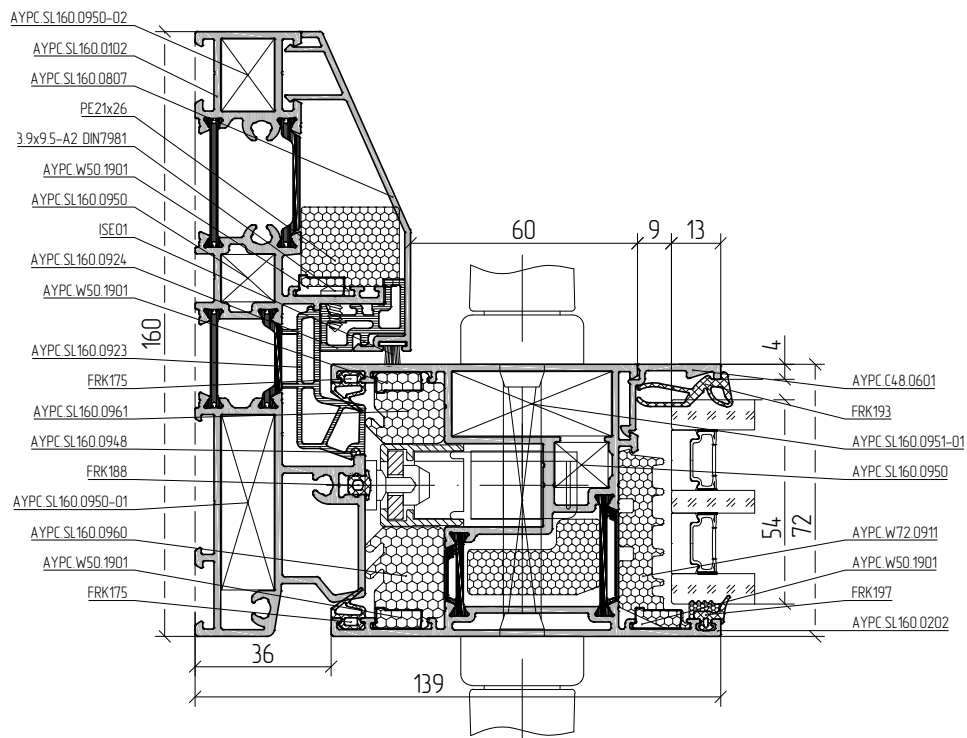

01

02

03

04

05

06

07

08

09

10

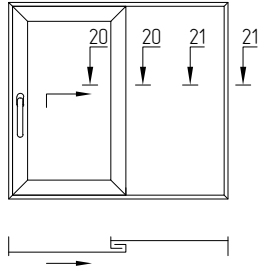

20-20

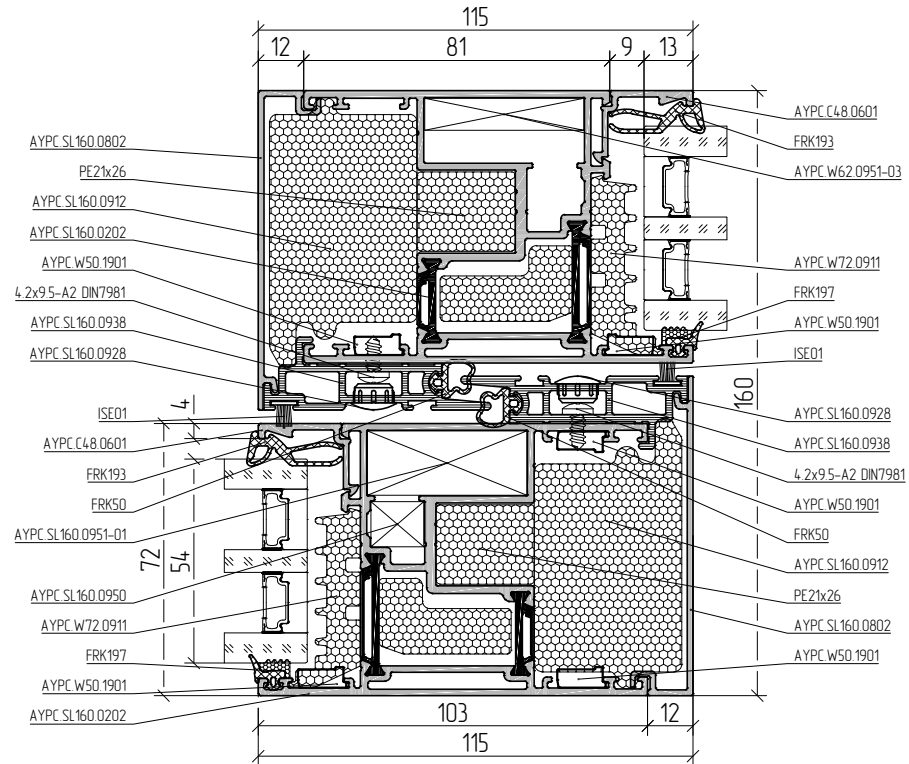

21-21

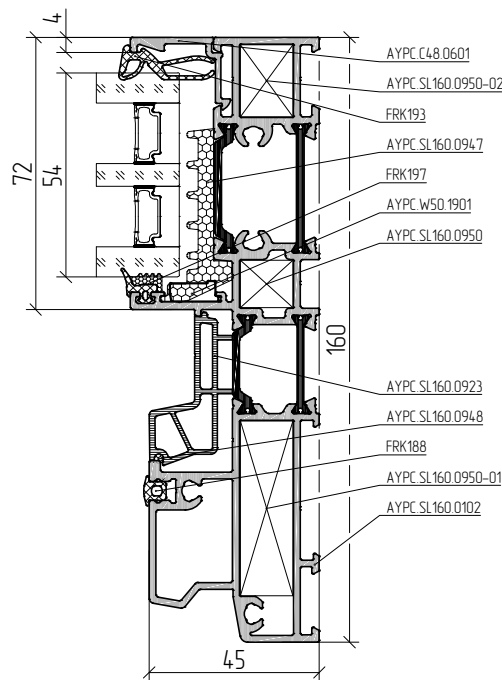

Scale 1:2

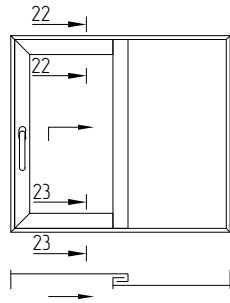

22-22

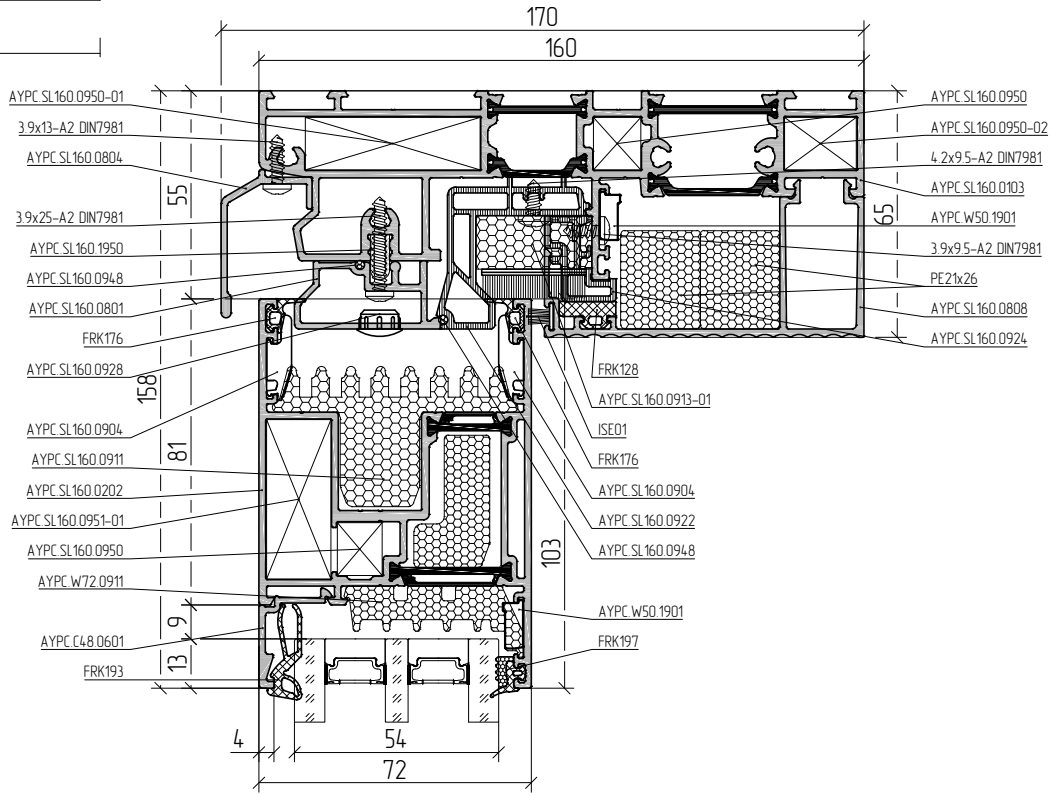

23-23

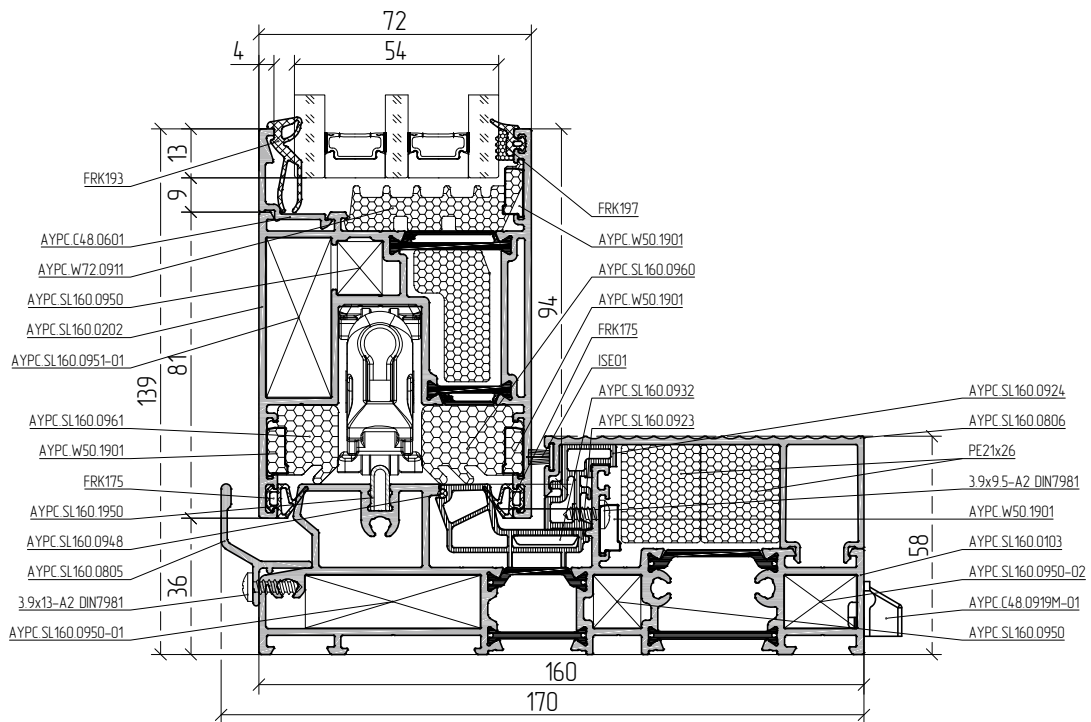

Scale 1:2

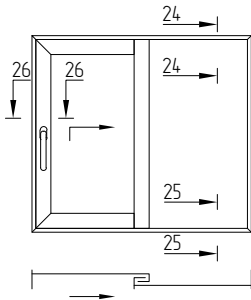

24-24

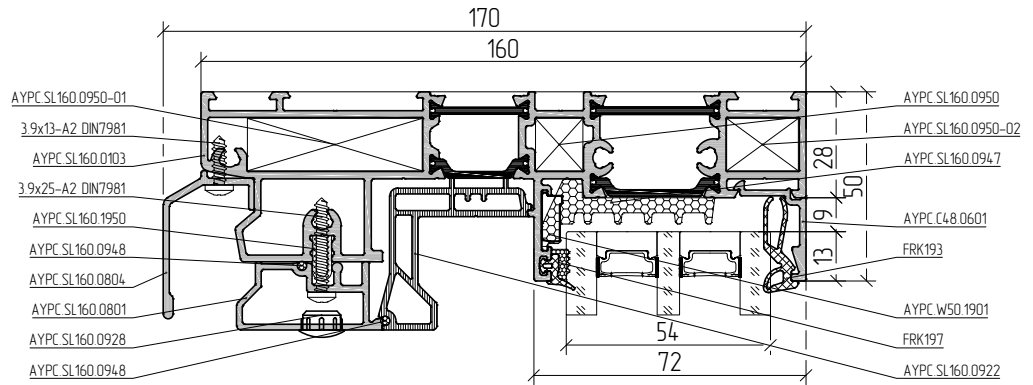

25-25

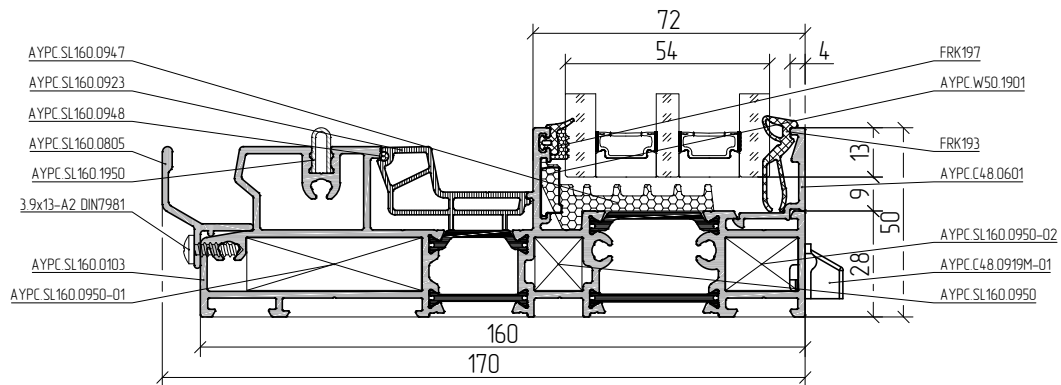

26-26

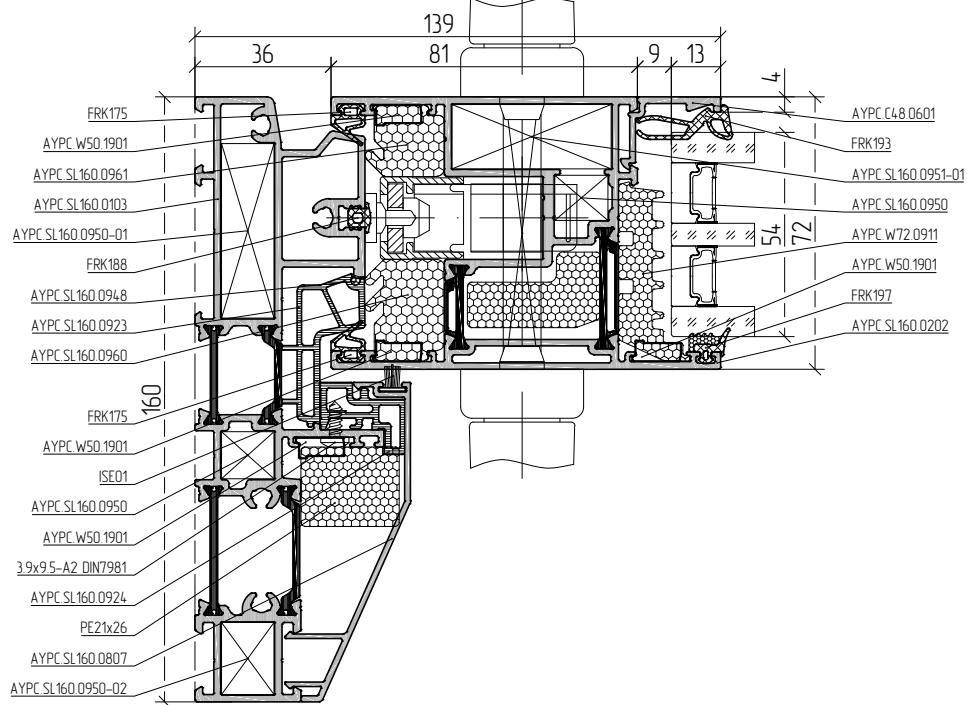

Scale 1:2

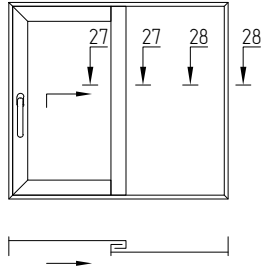

27-27

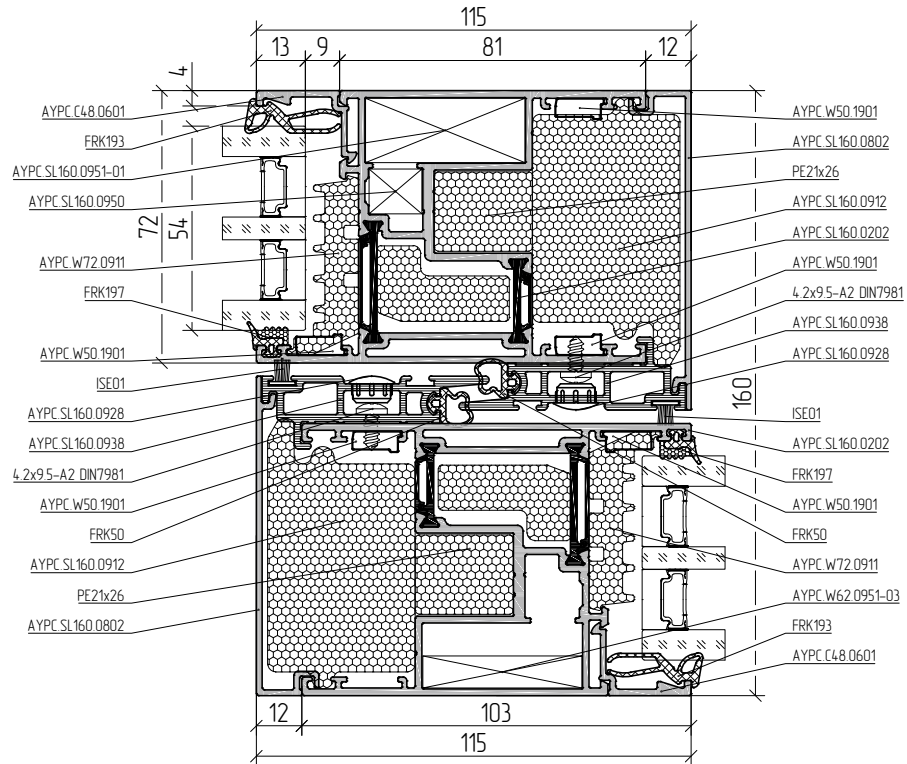

28-28

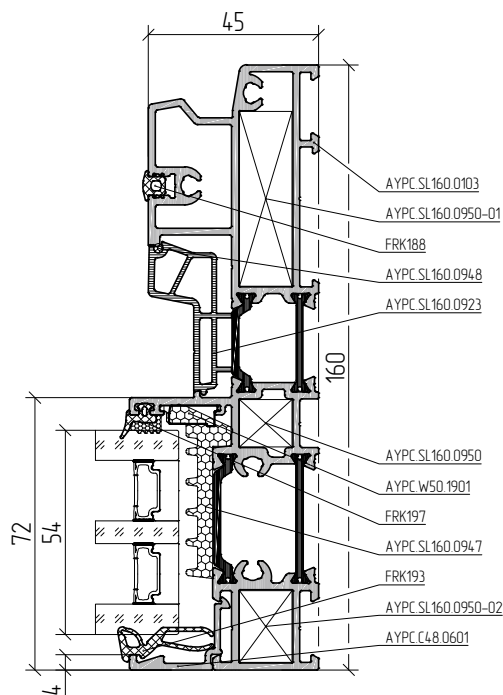

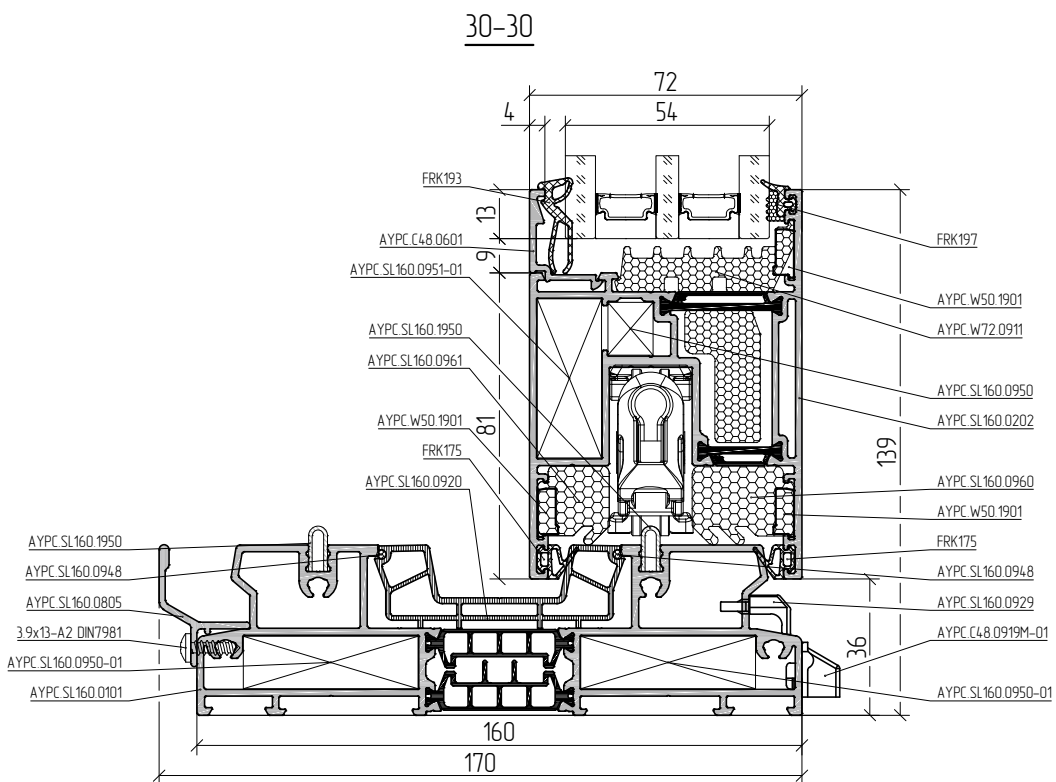
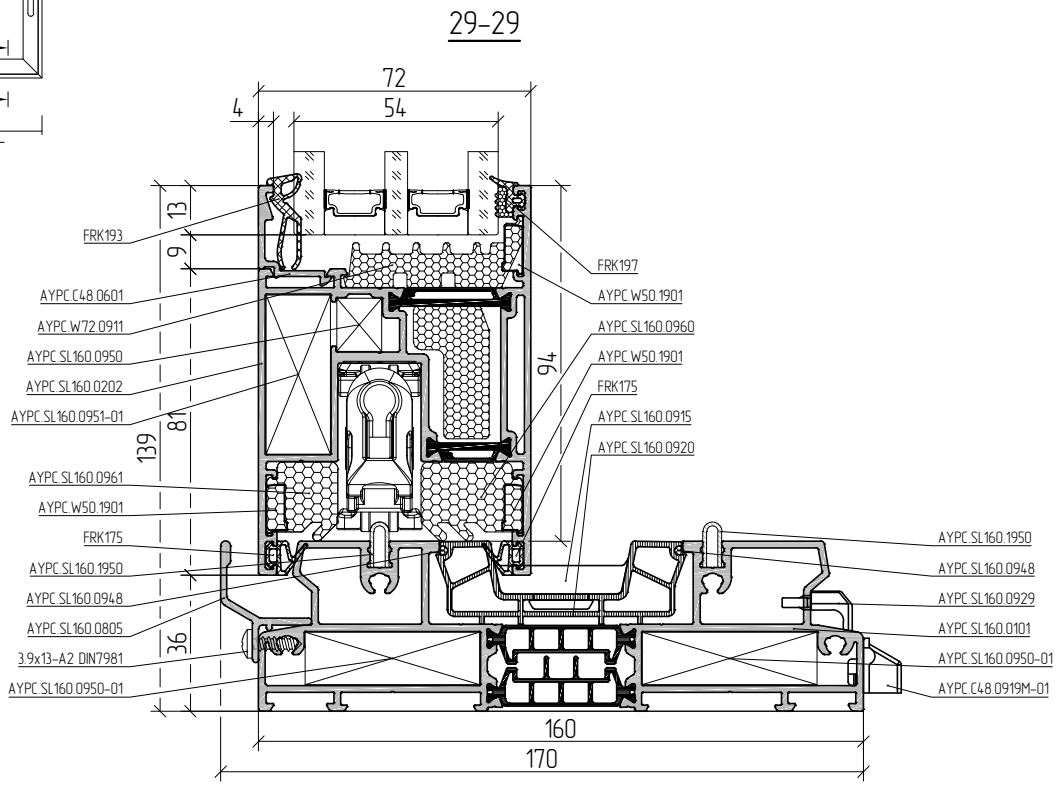
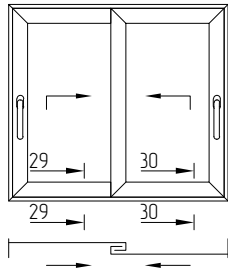

Scale 1:2

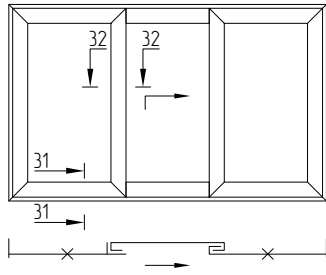

31-31

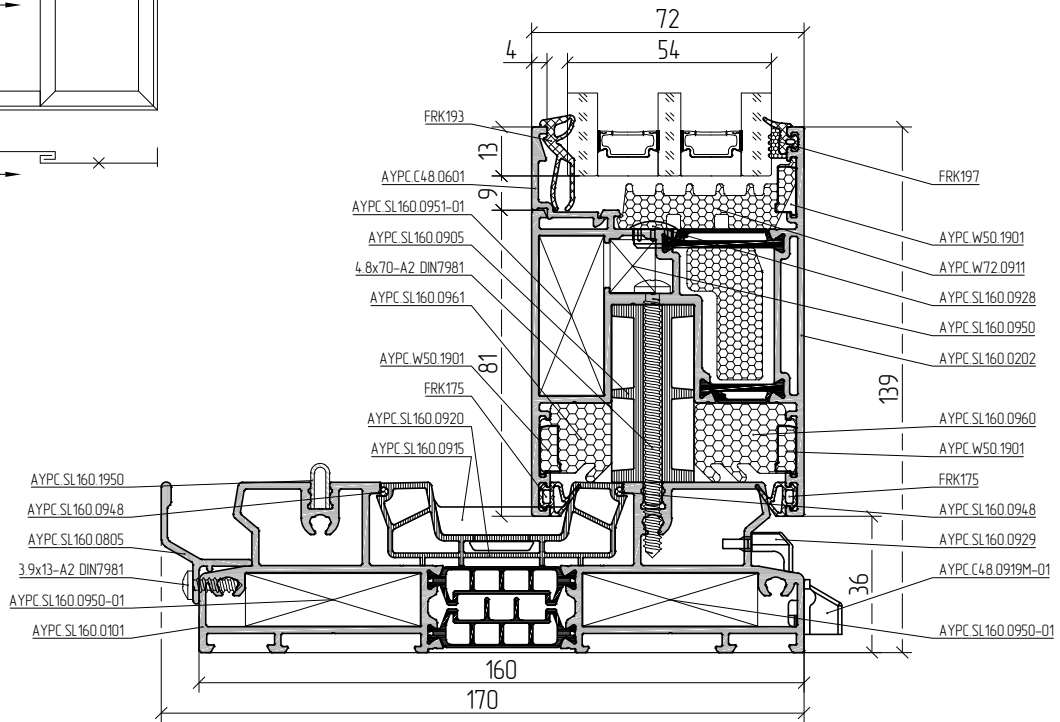

32-32

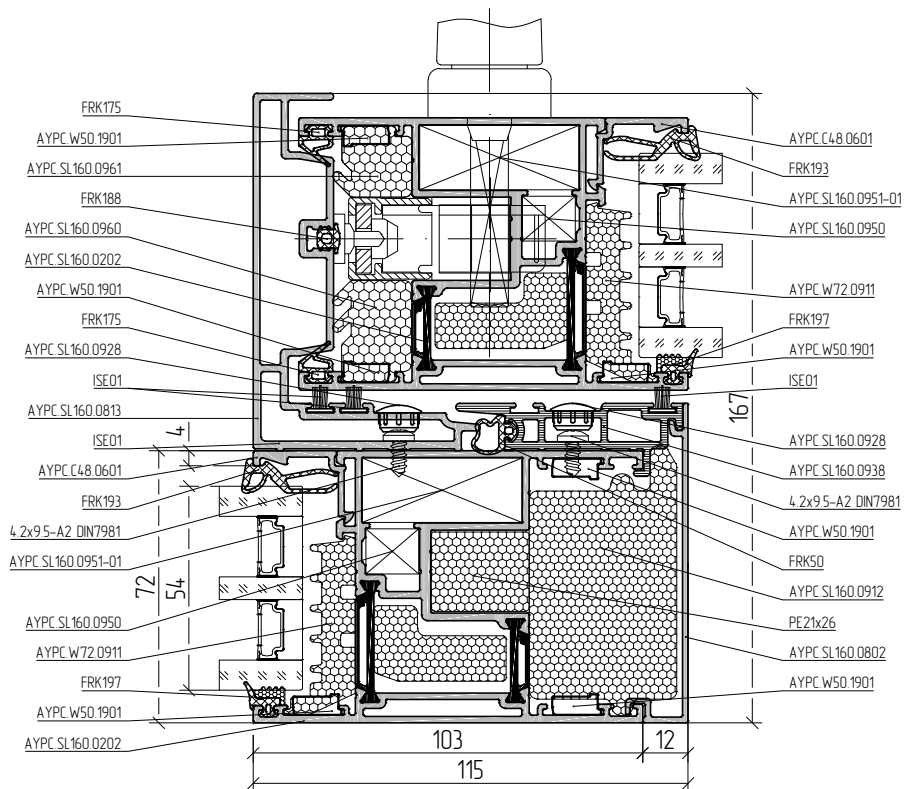

Scale 1:2

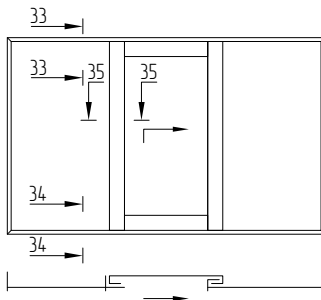

33-33

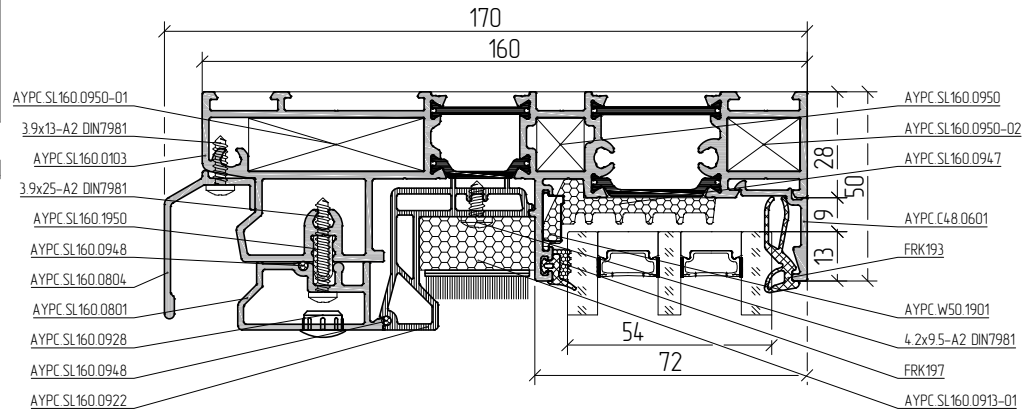

34-34

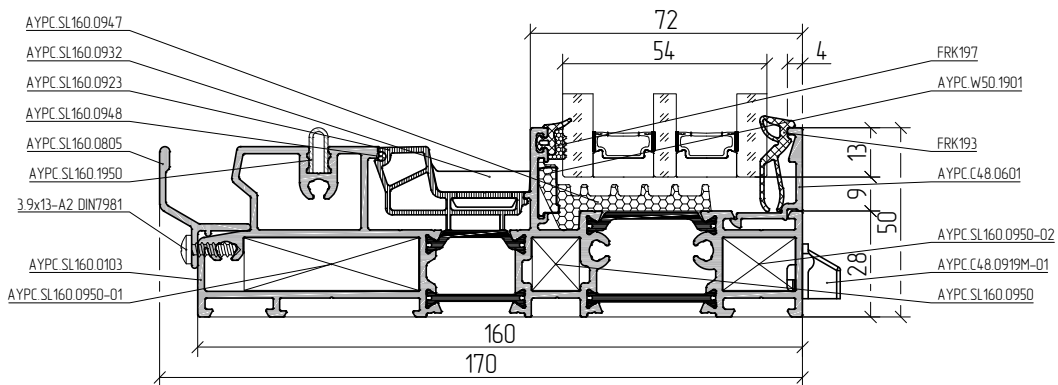

35-35

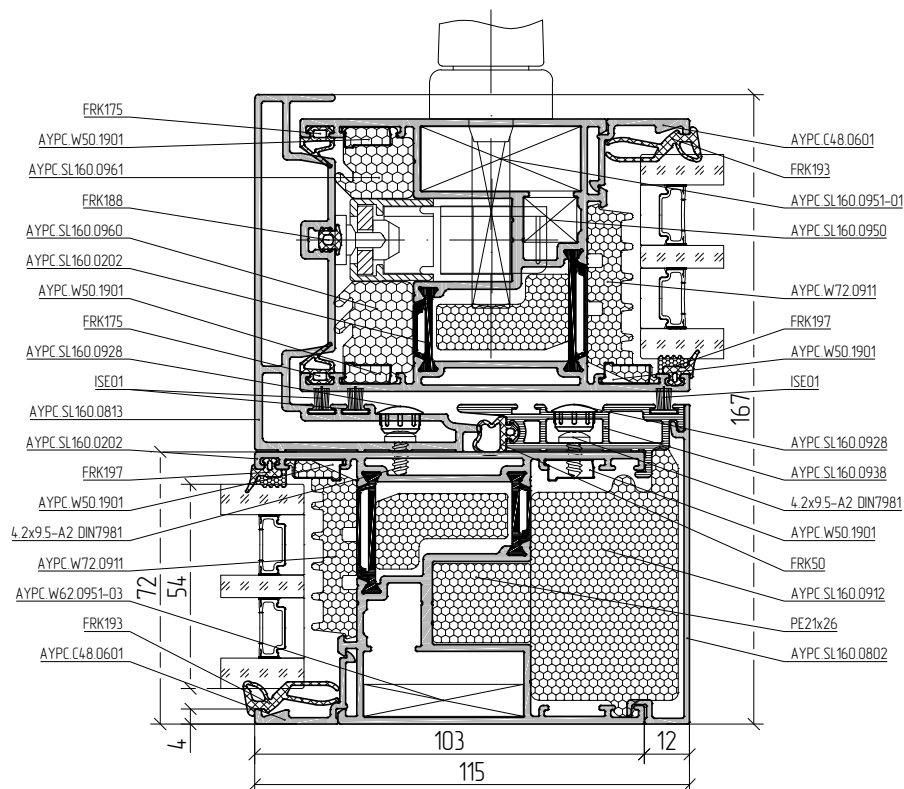

Scale 1:2

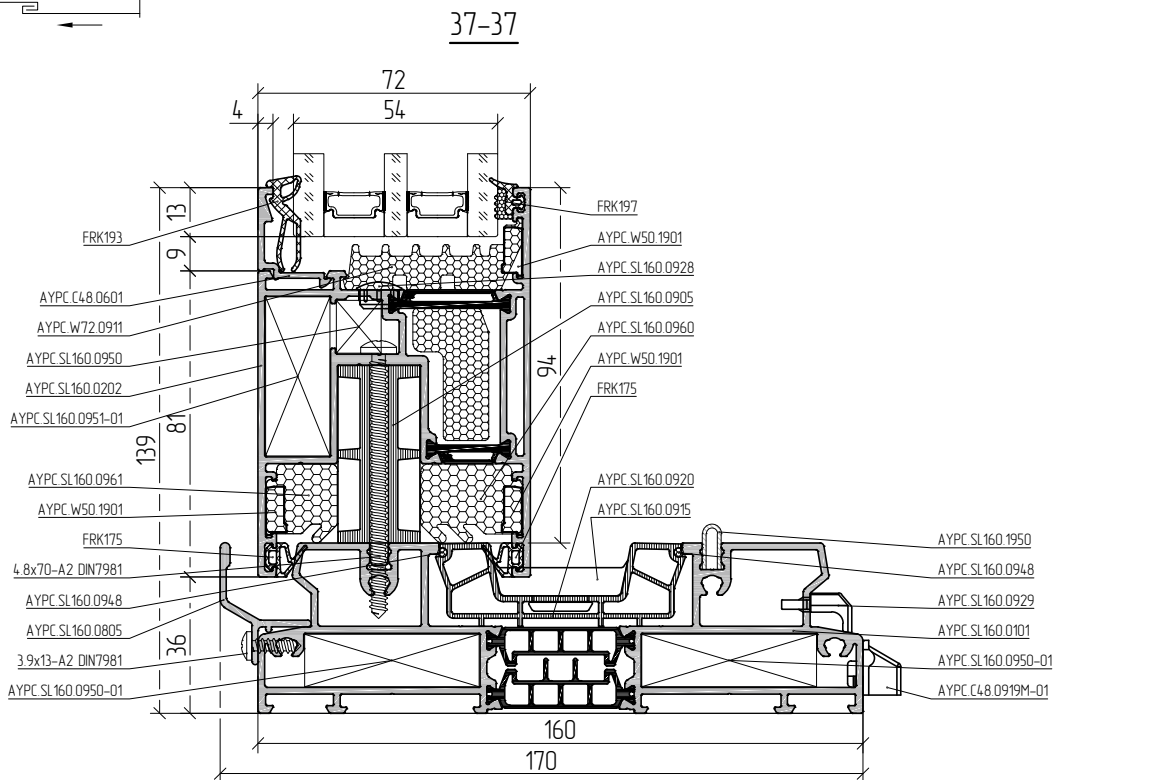
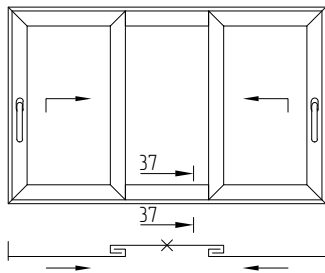
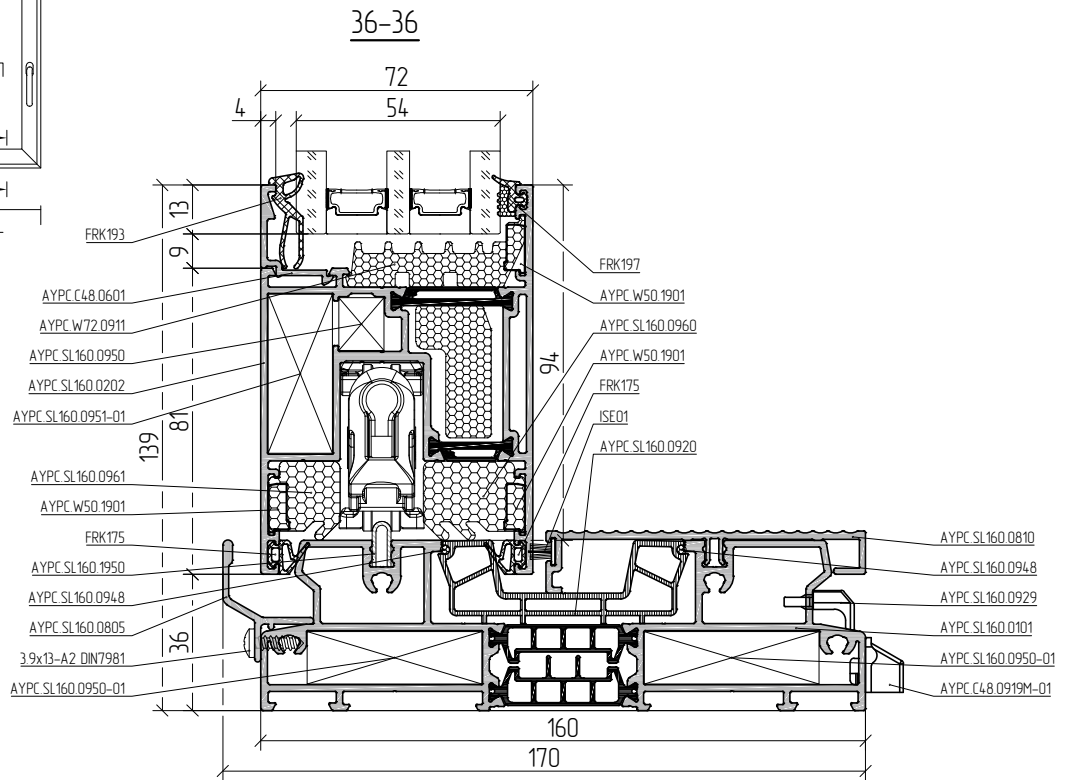
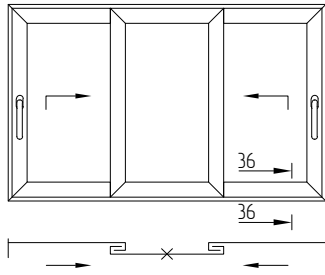

Scale 1:2

01

02

03

04

05

06

07

08

09

10

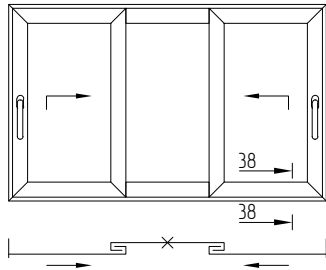

38-38

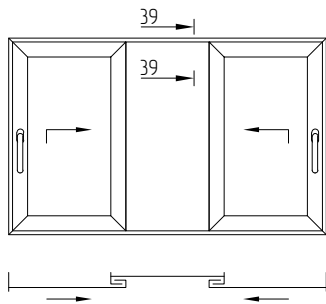
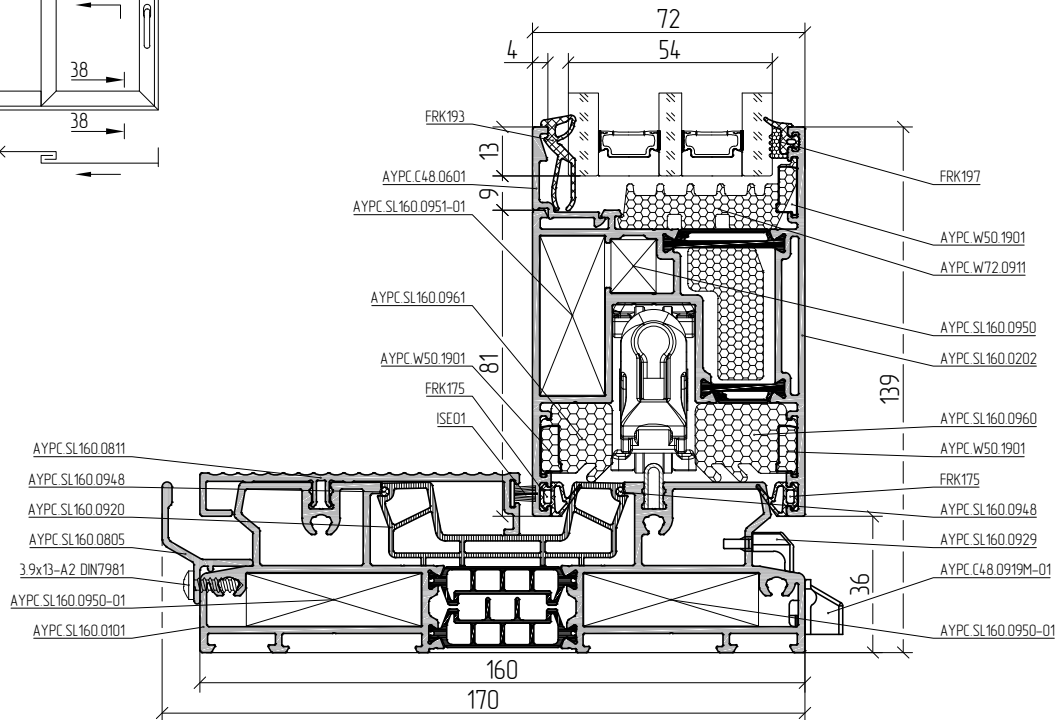

39-39

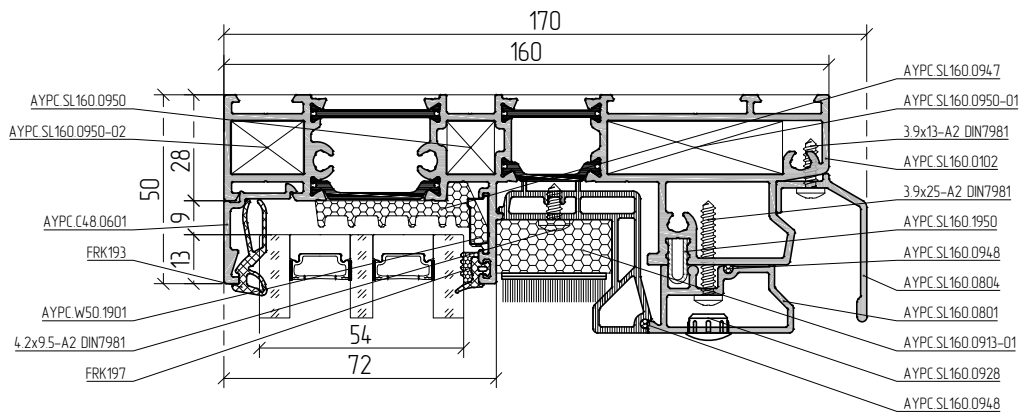

Scale 1:2

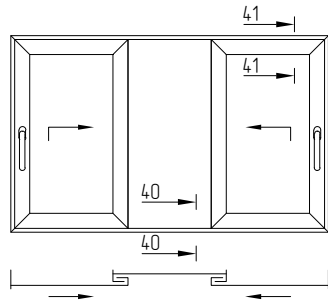

40-40

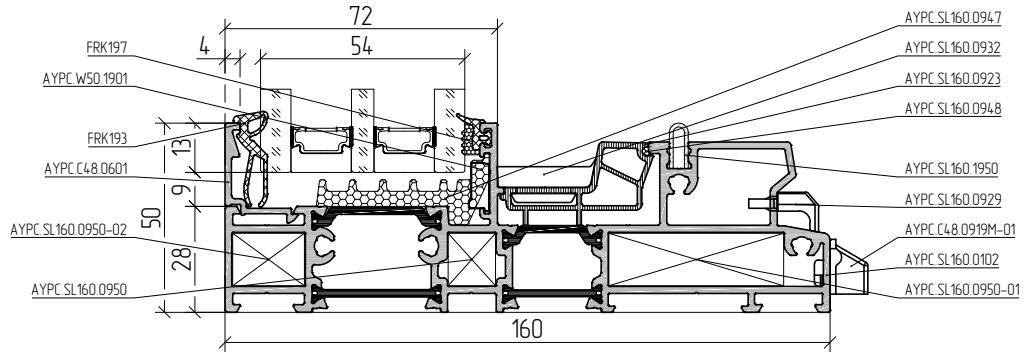

41-41

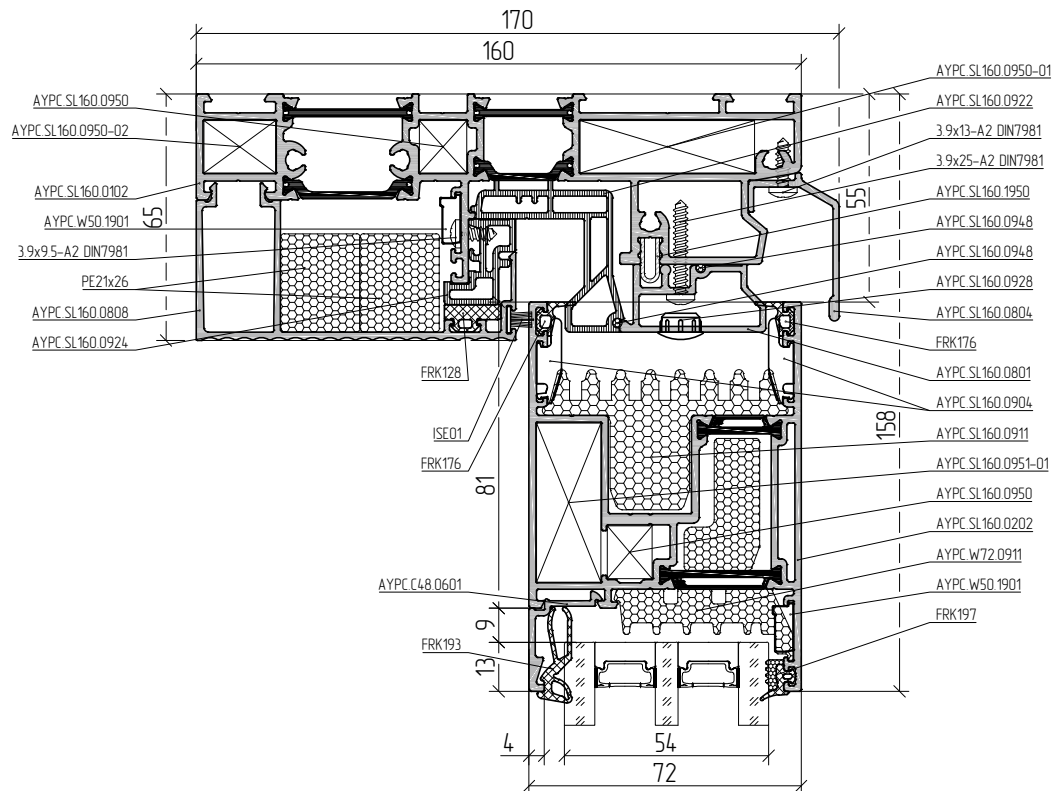

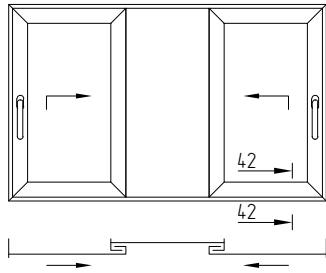

42-42

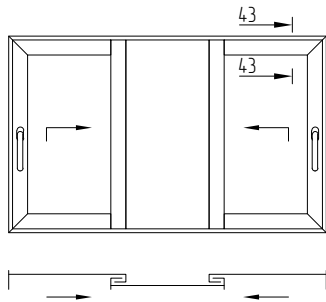
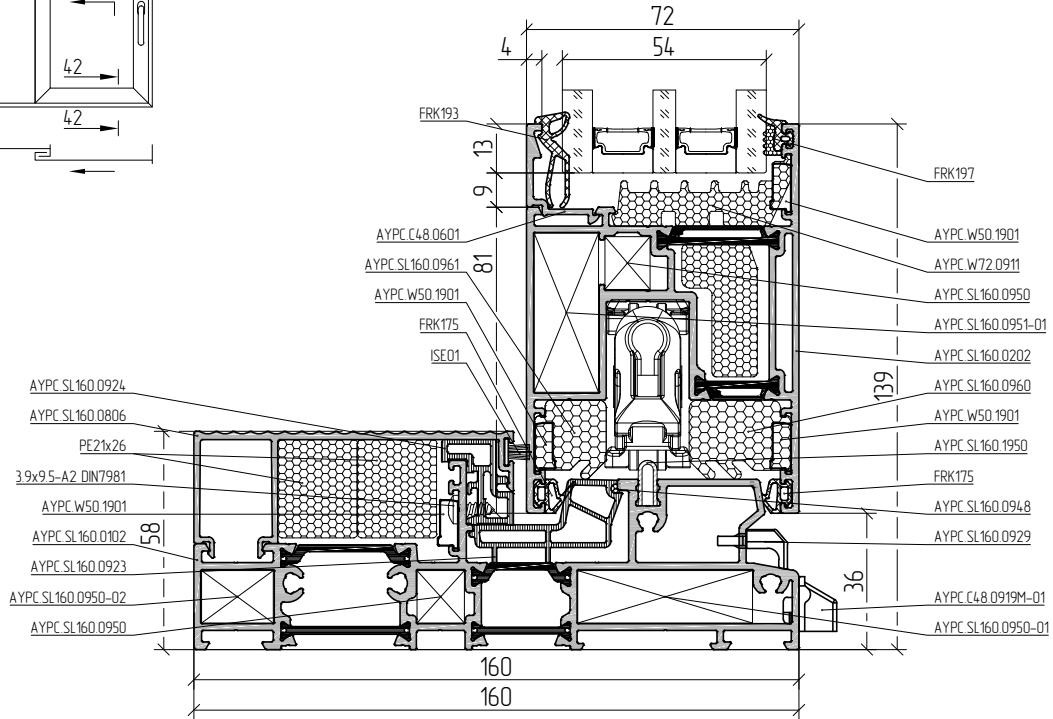

43-43

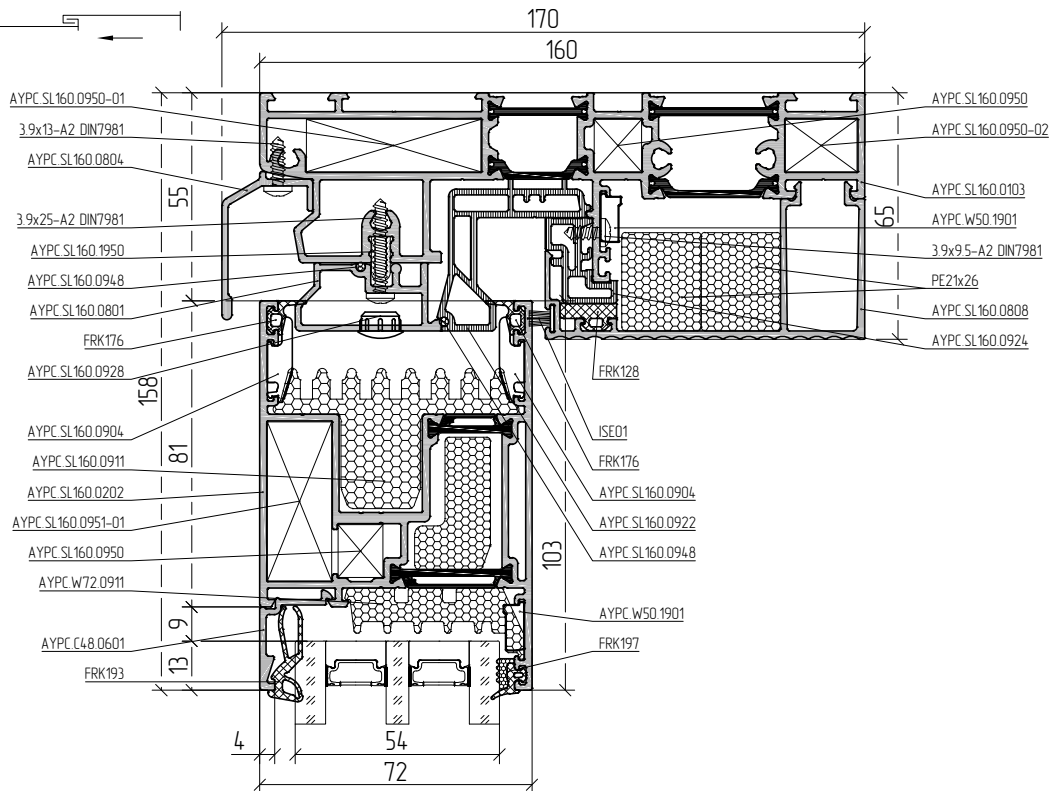

Scale 1:2

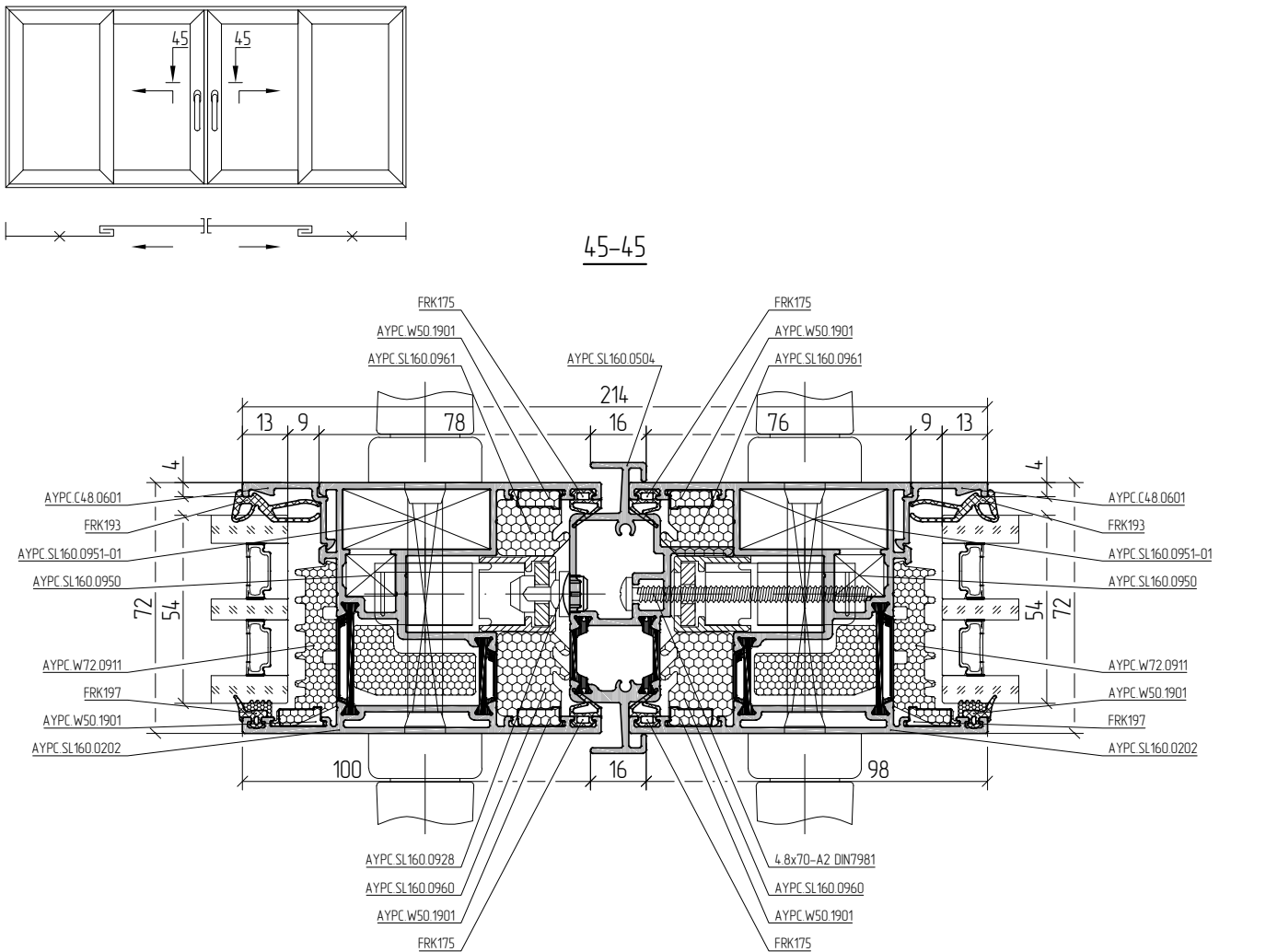
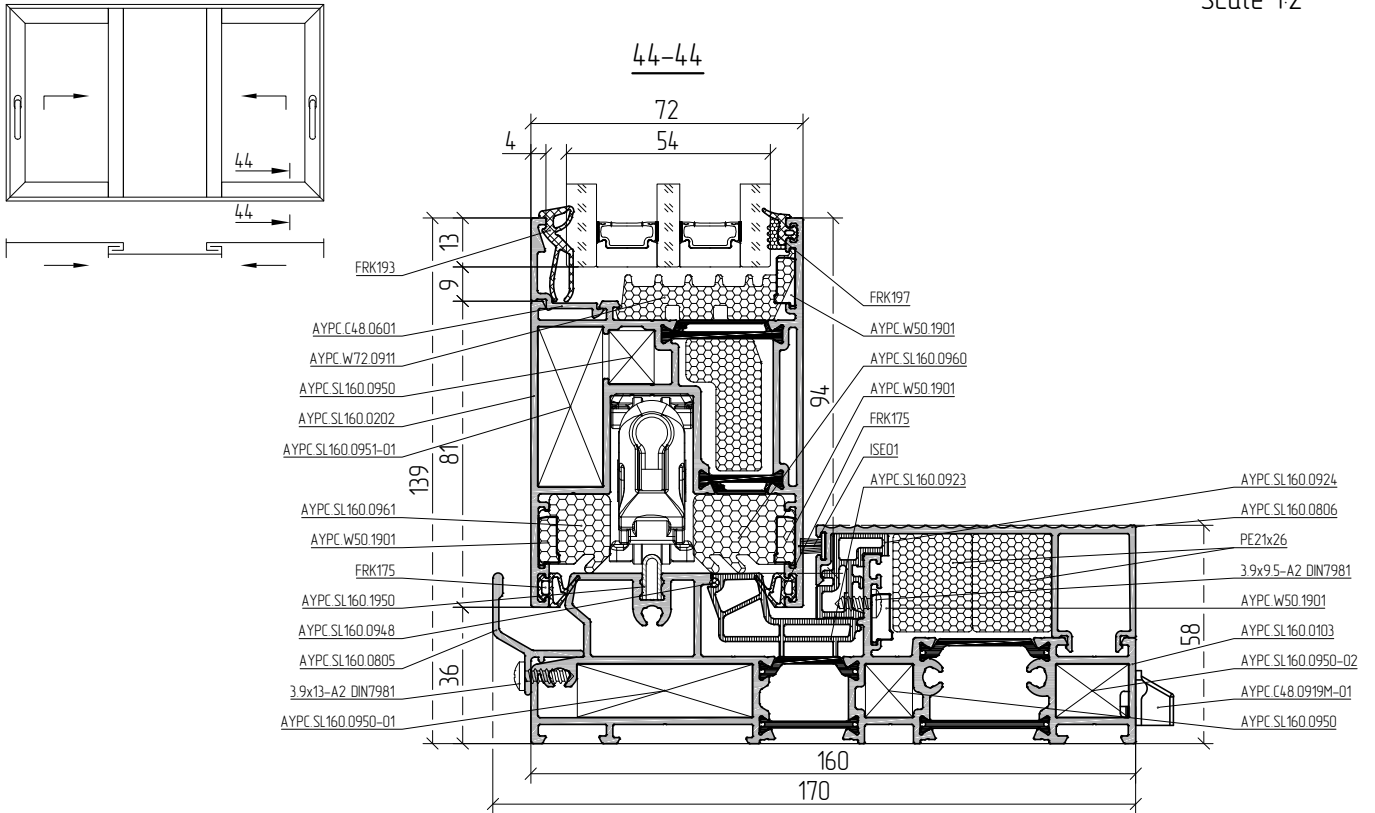

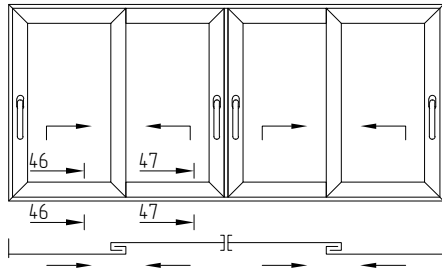

46-46

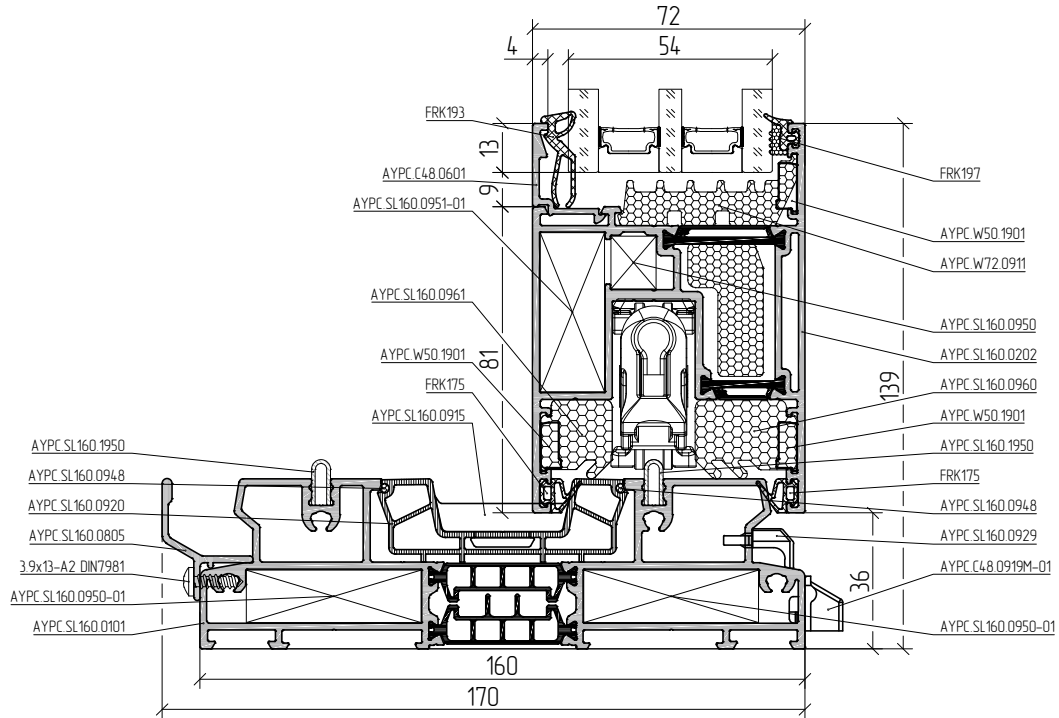

47-47

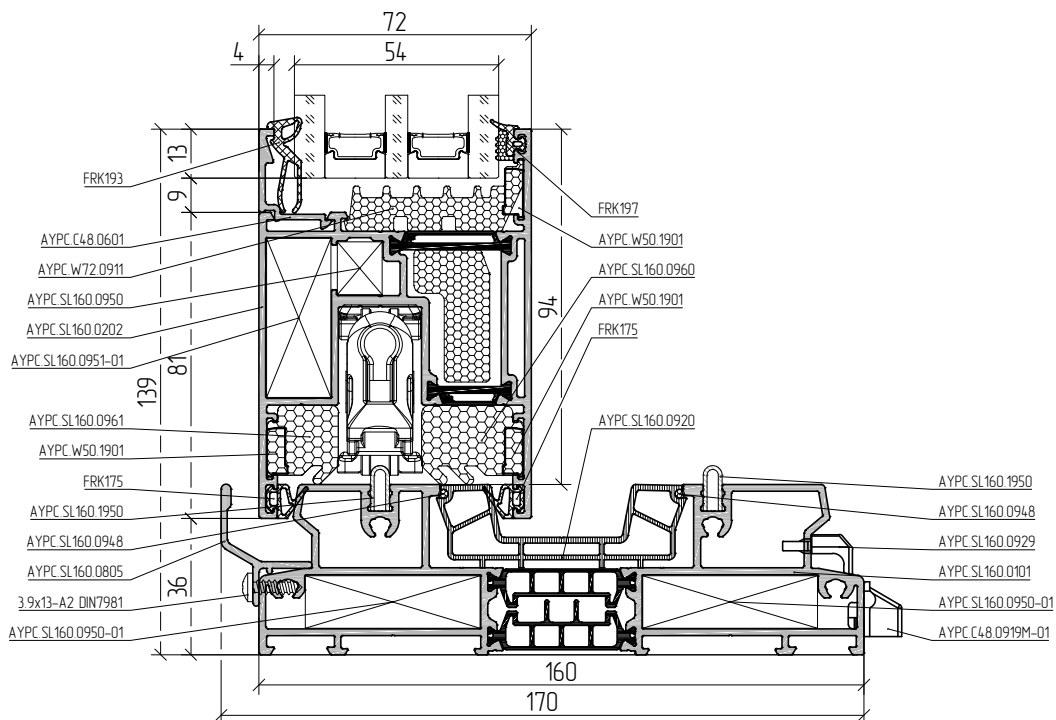

Scale 1:2

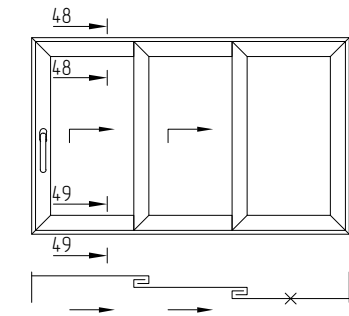

48-48

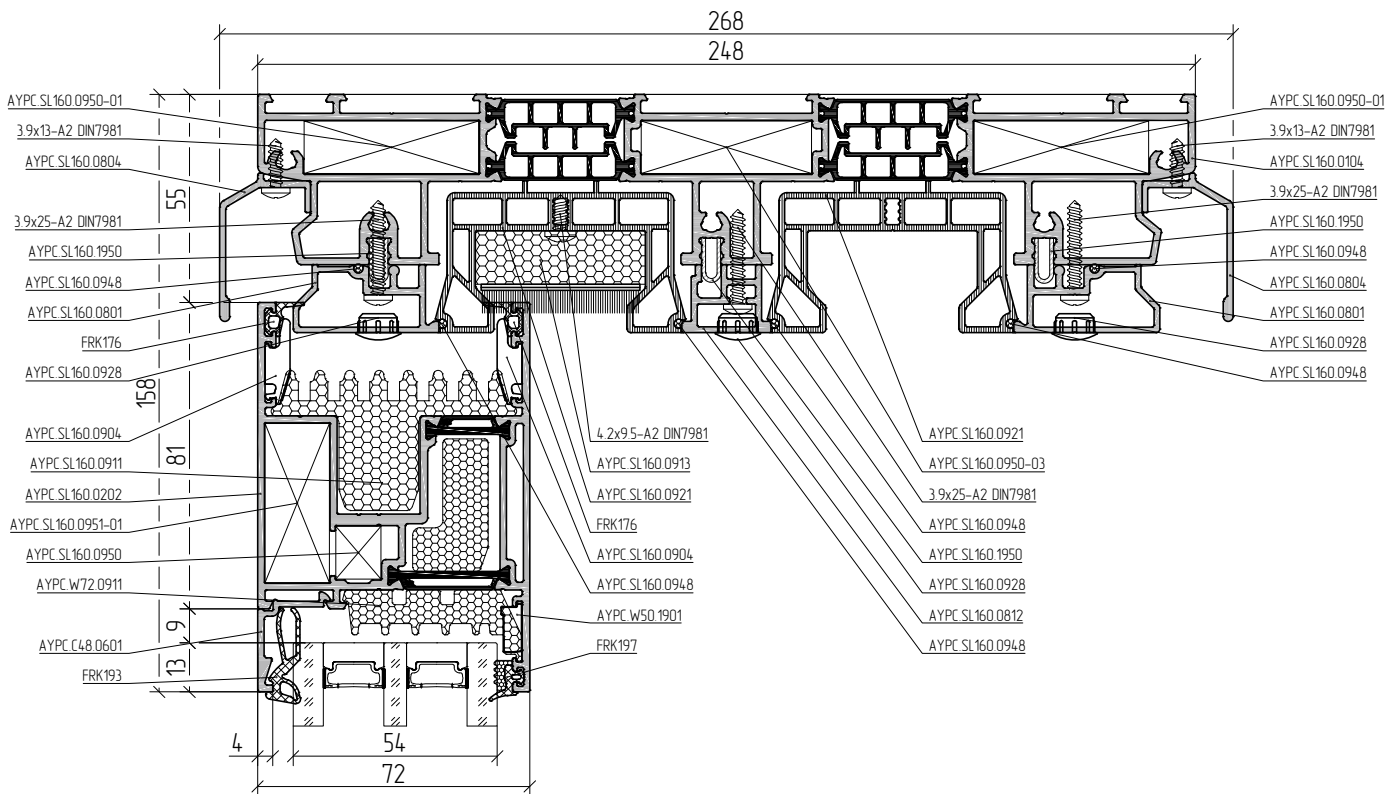

49-49

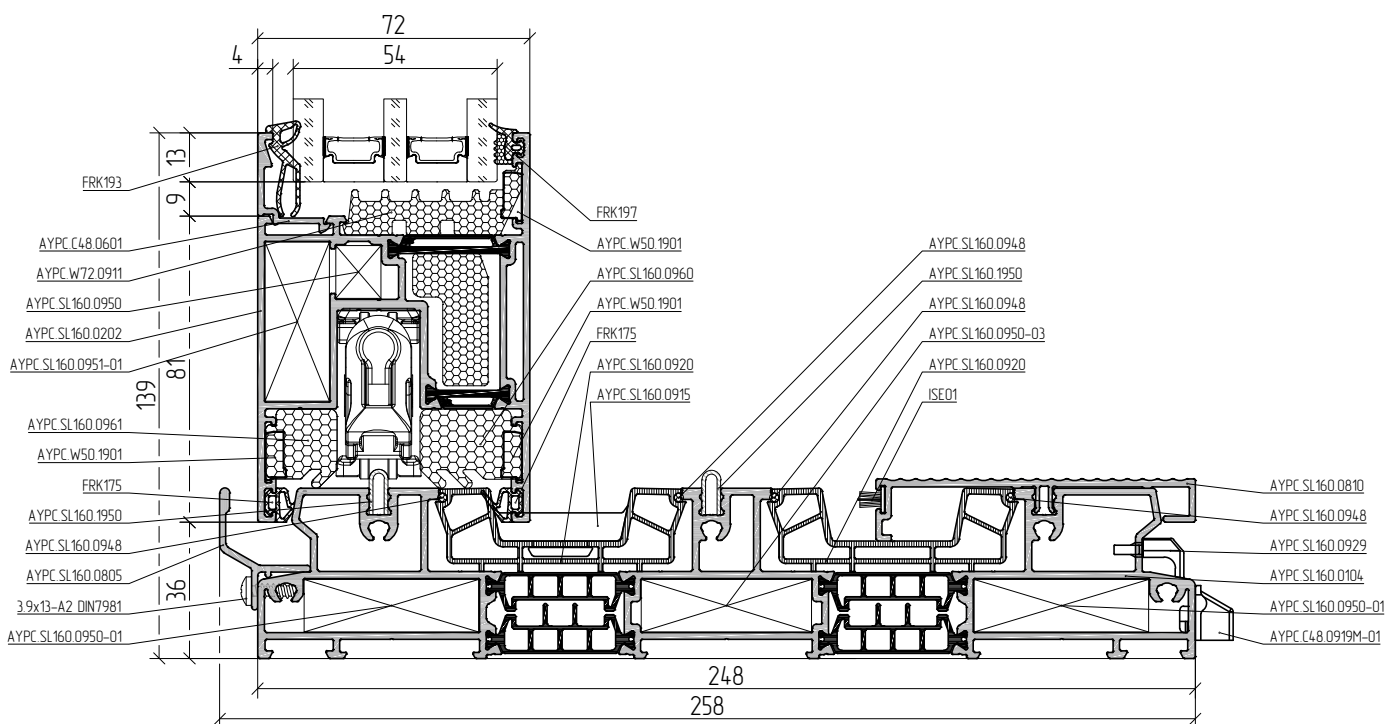

Scale 1:2

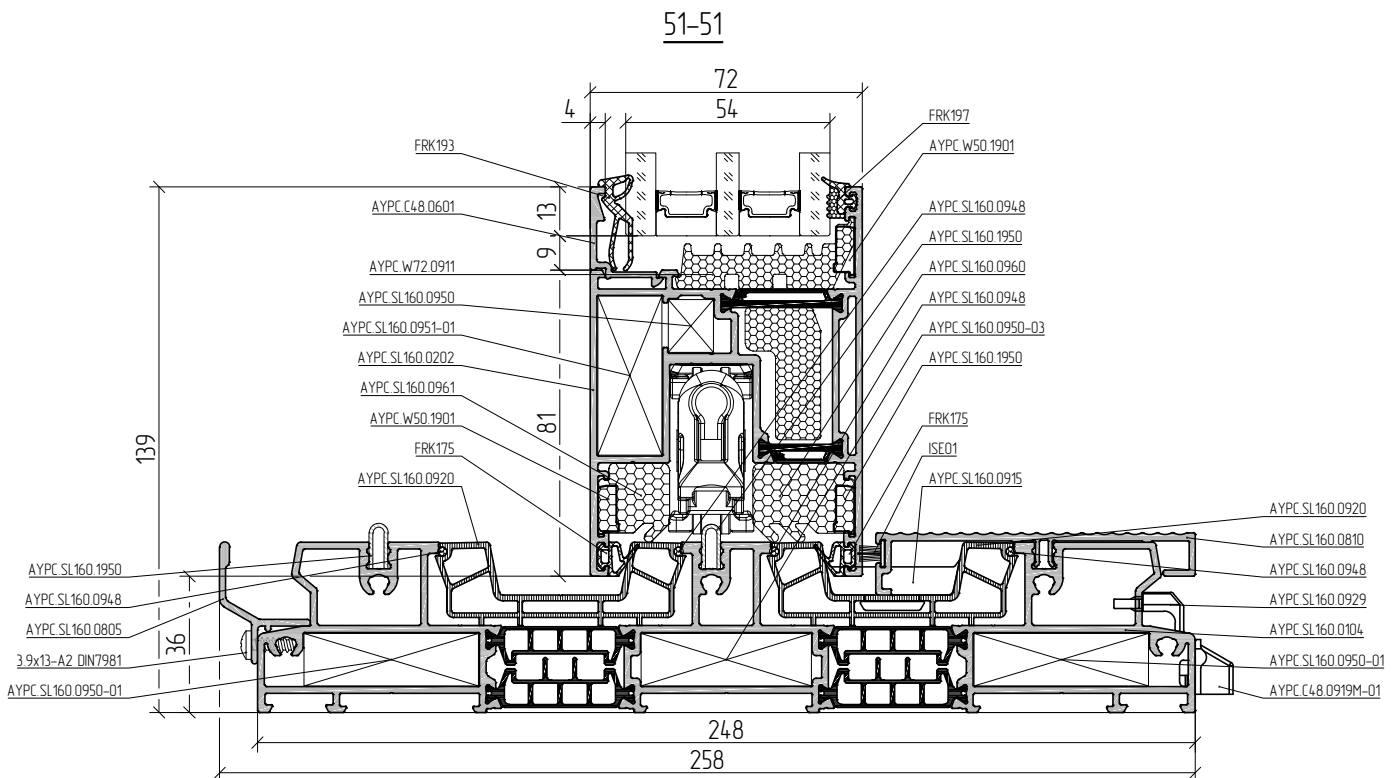
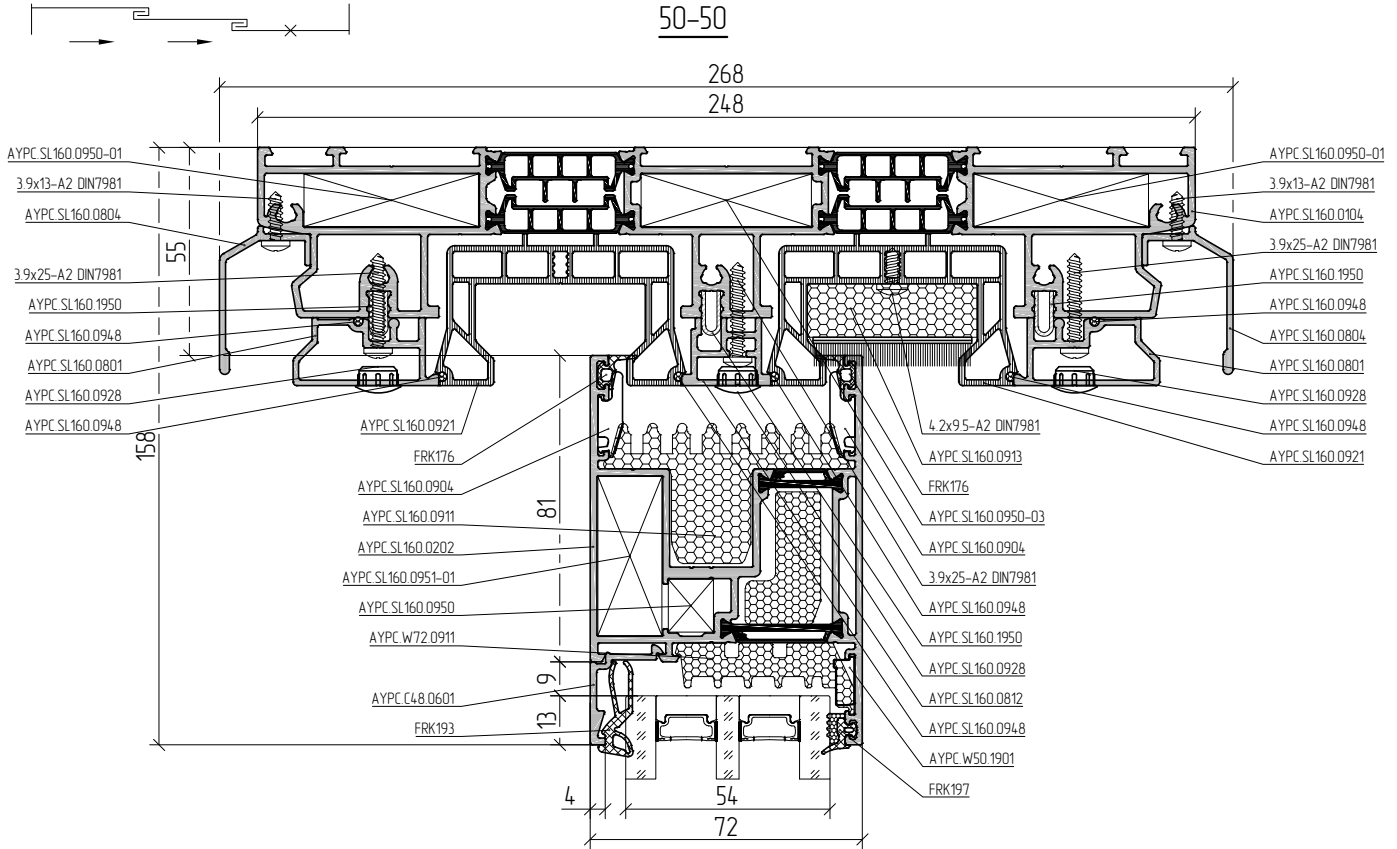
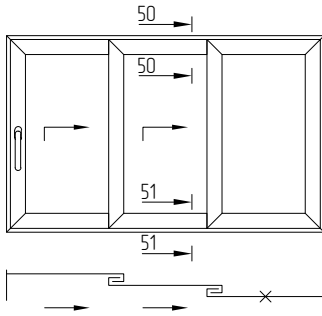

Scale 1:2

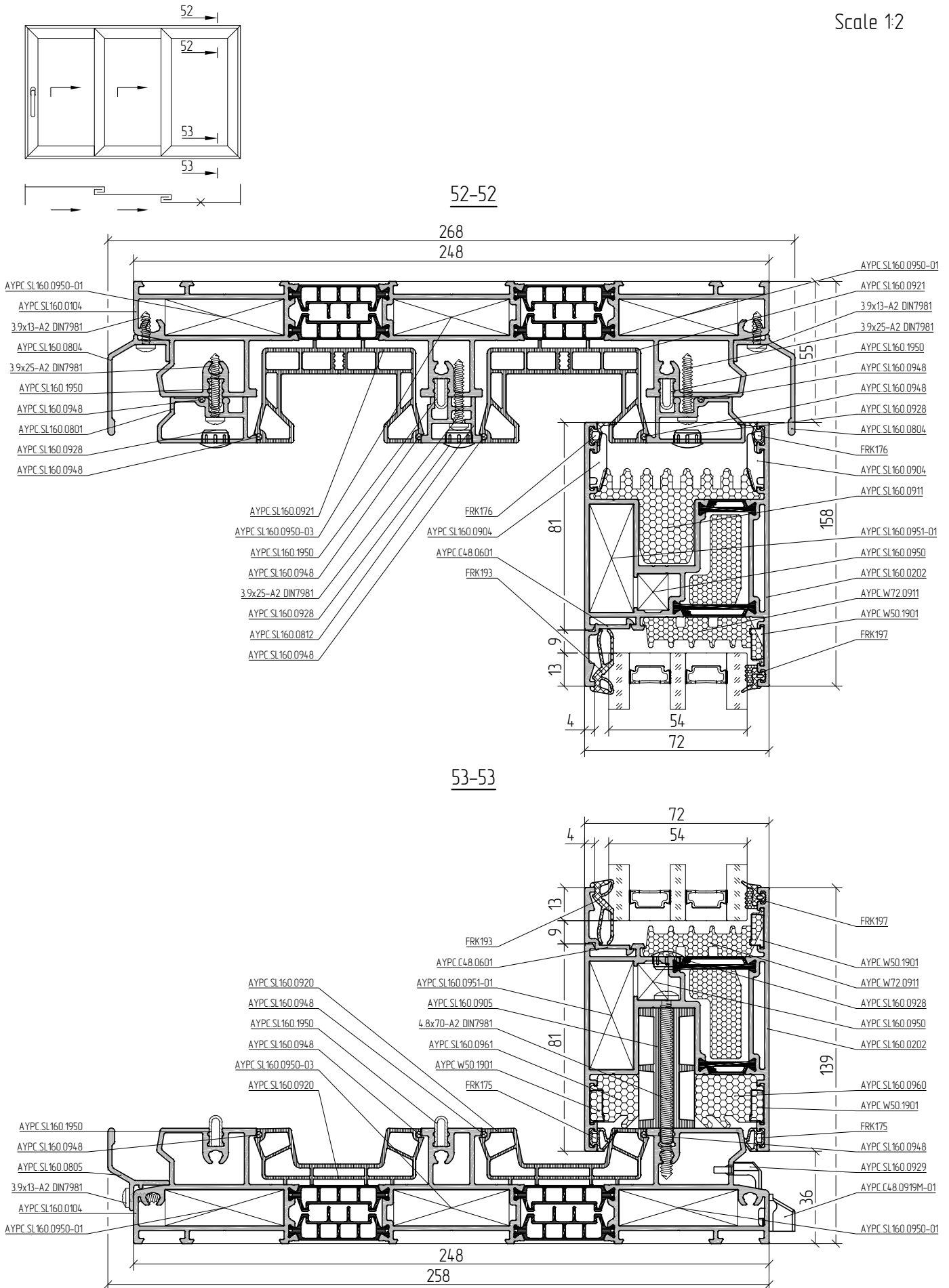

Scale 1:2

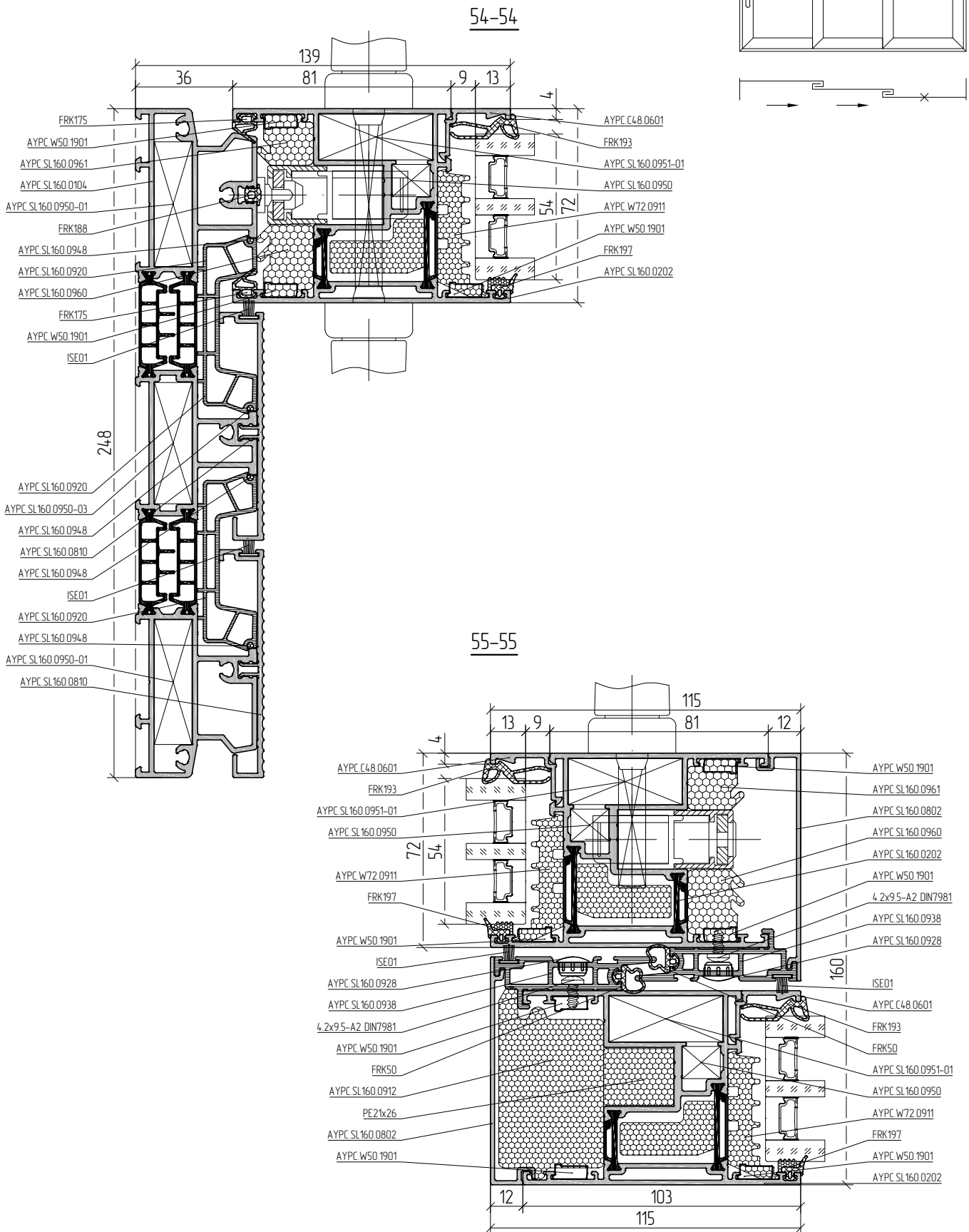

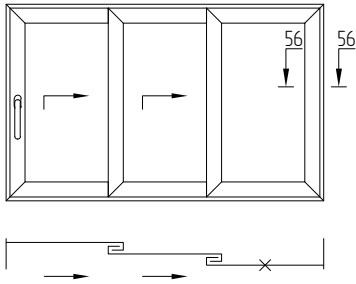

56-56

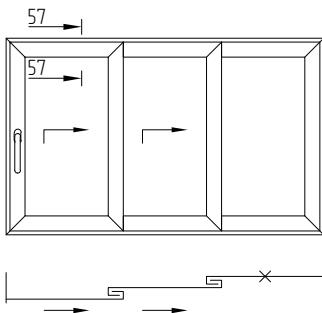
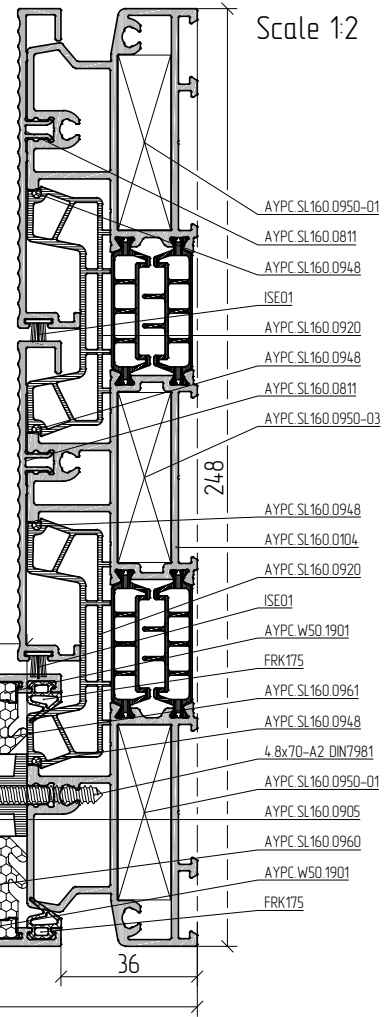

57-57

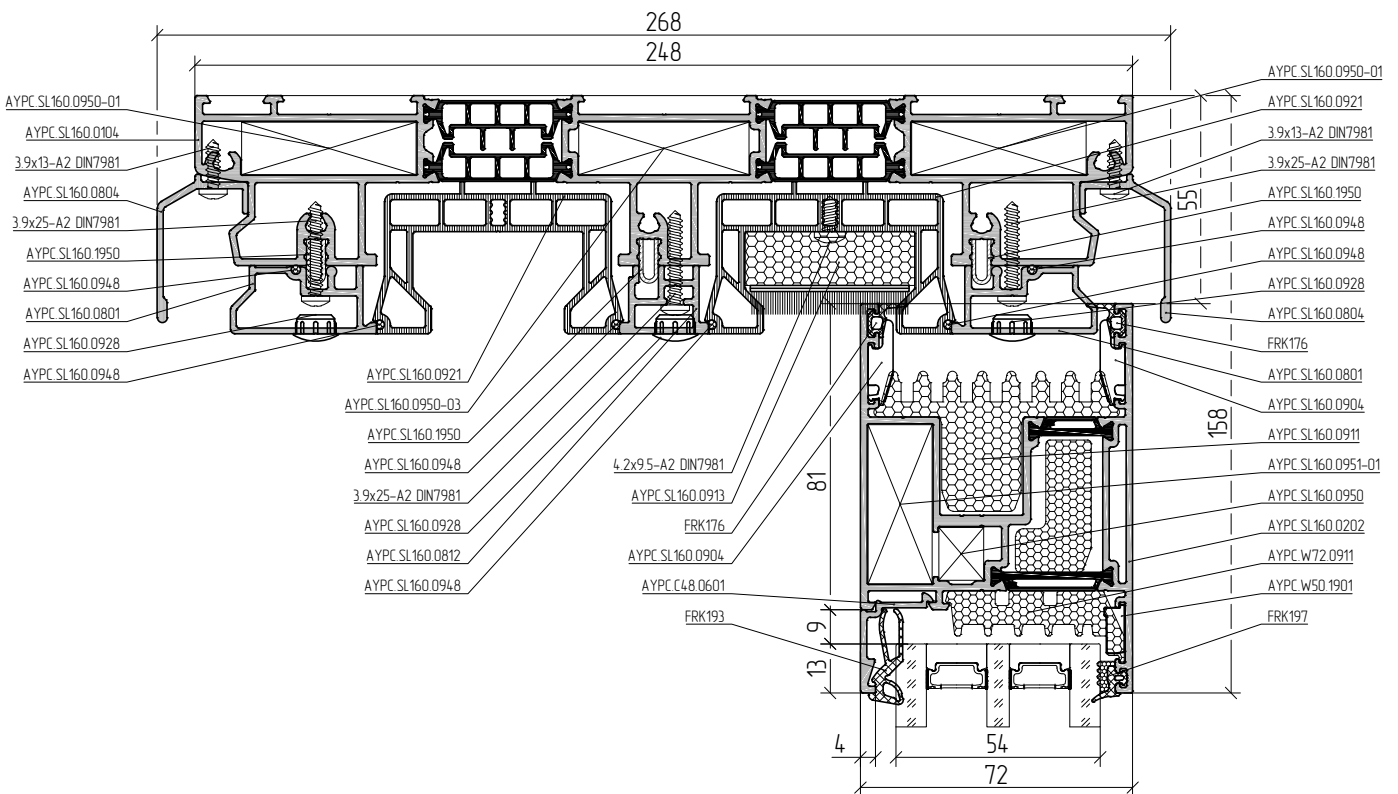

Scale 1:2

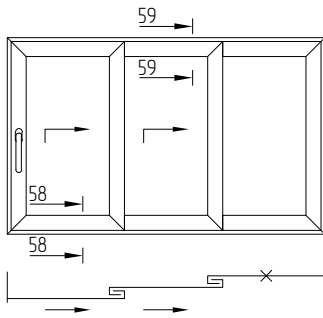

58-58

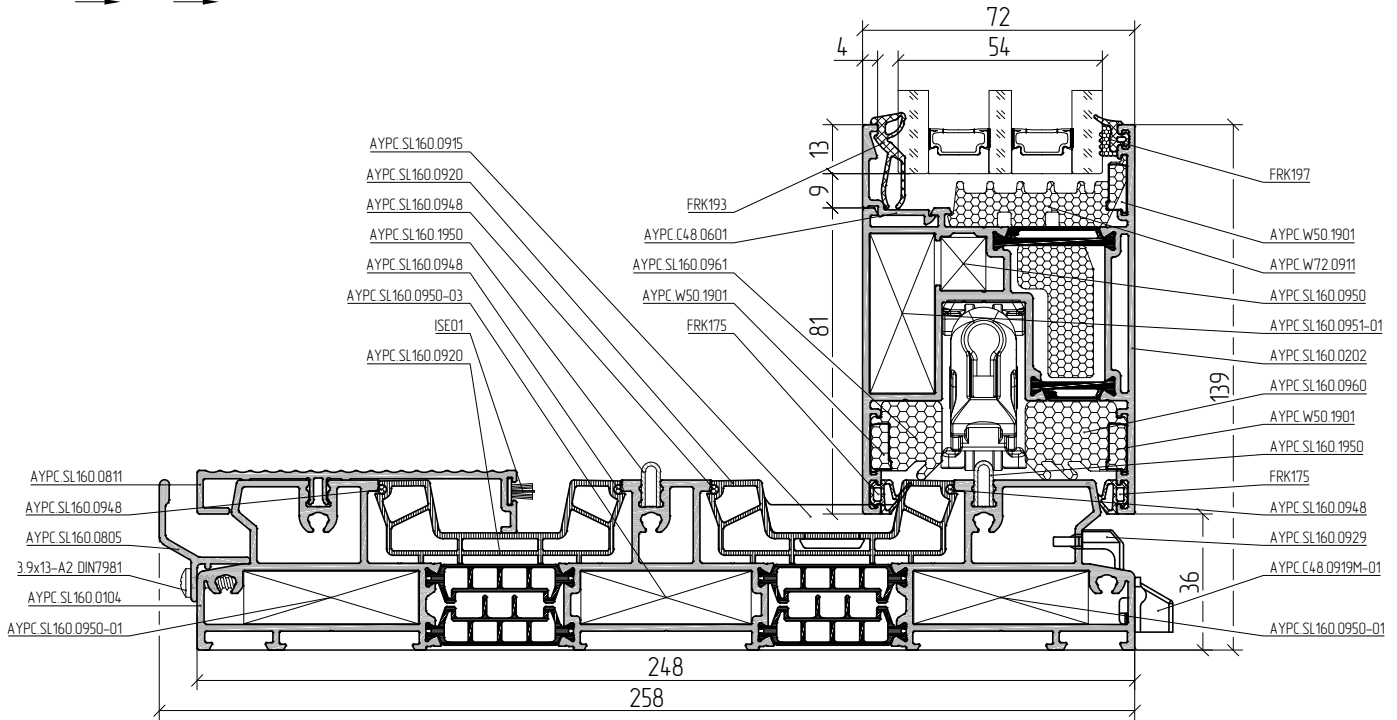

59-59

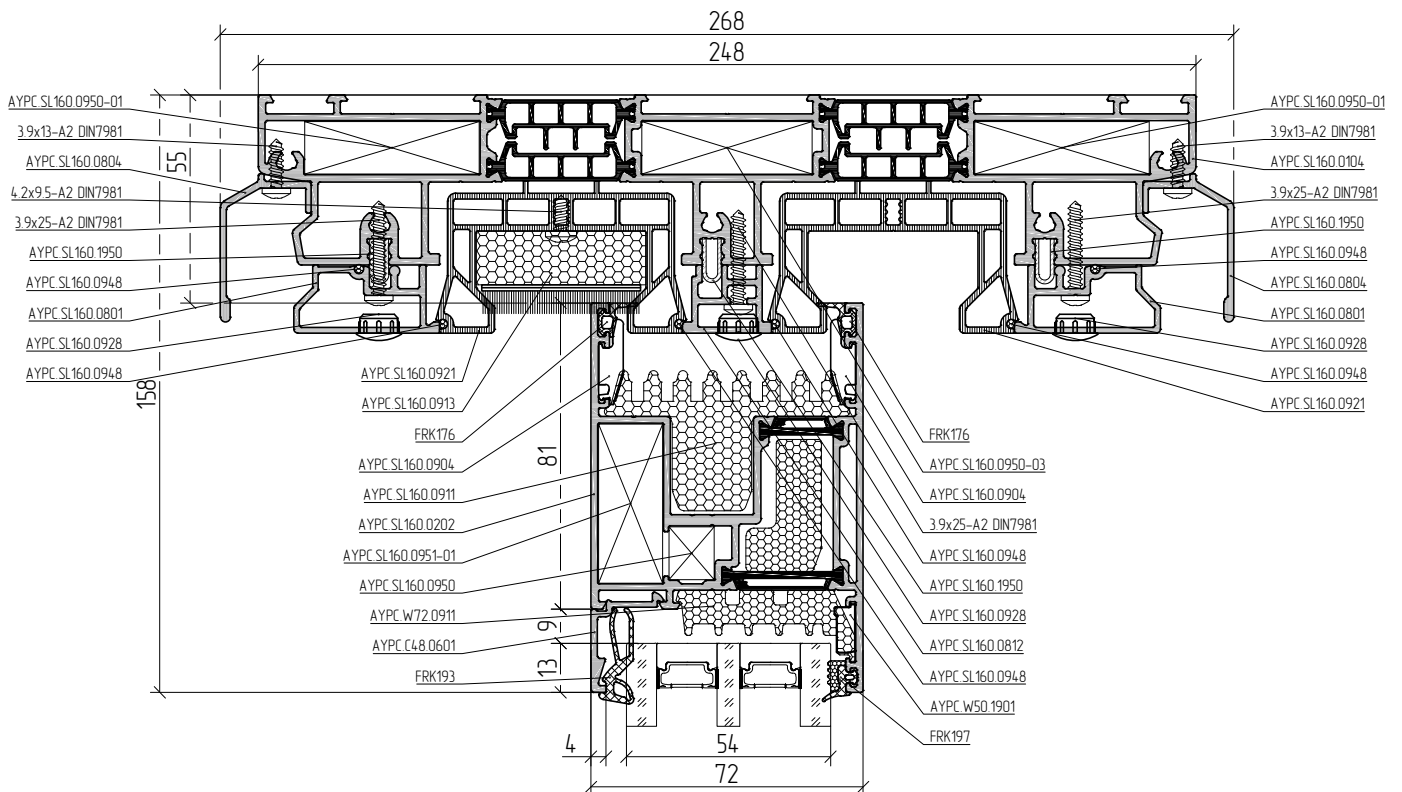

Scale 1:2

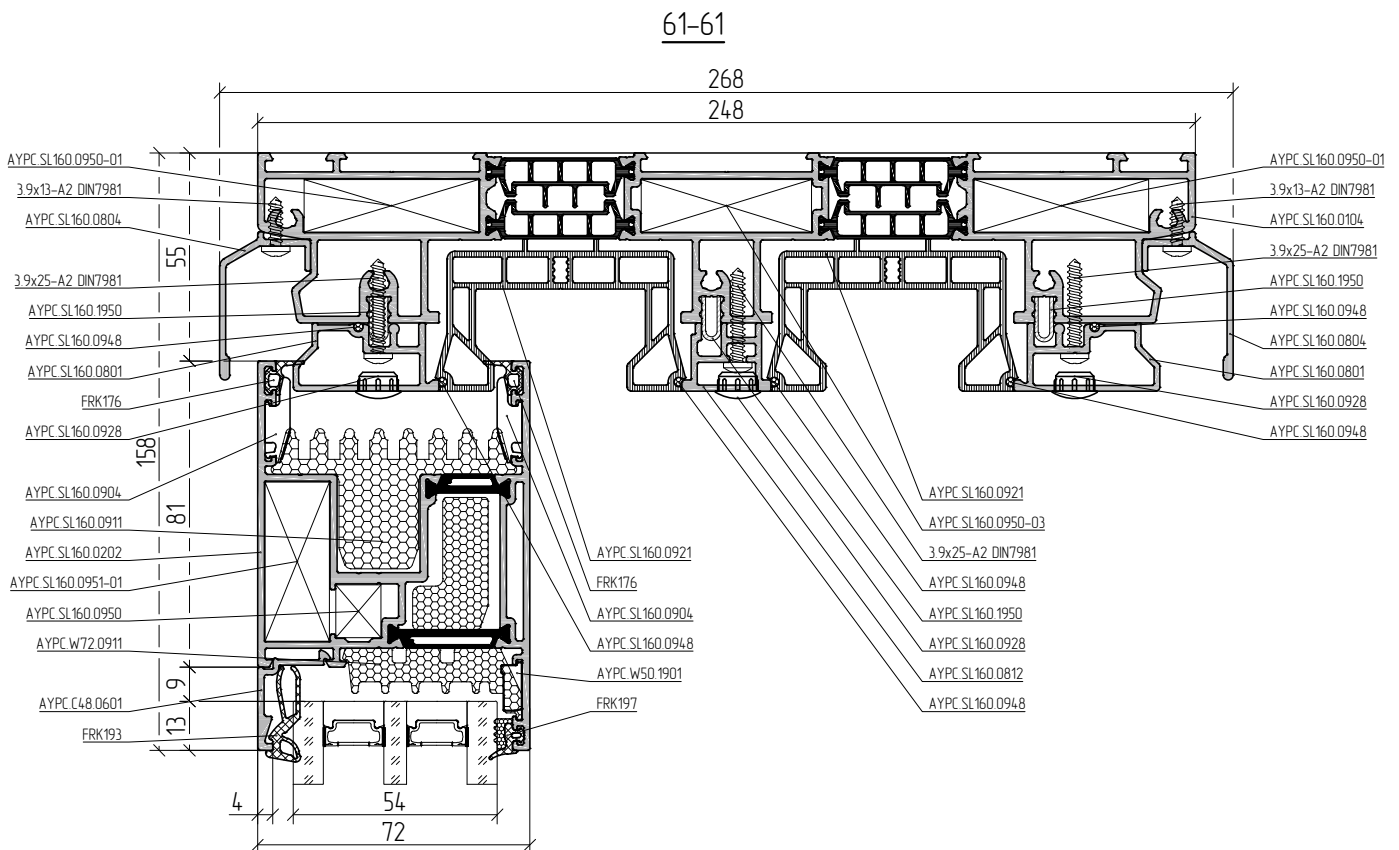
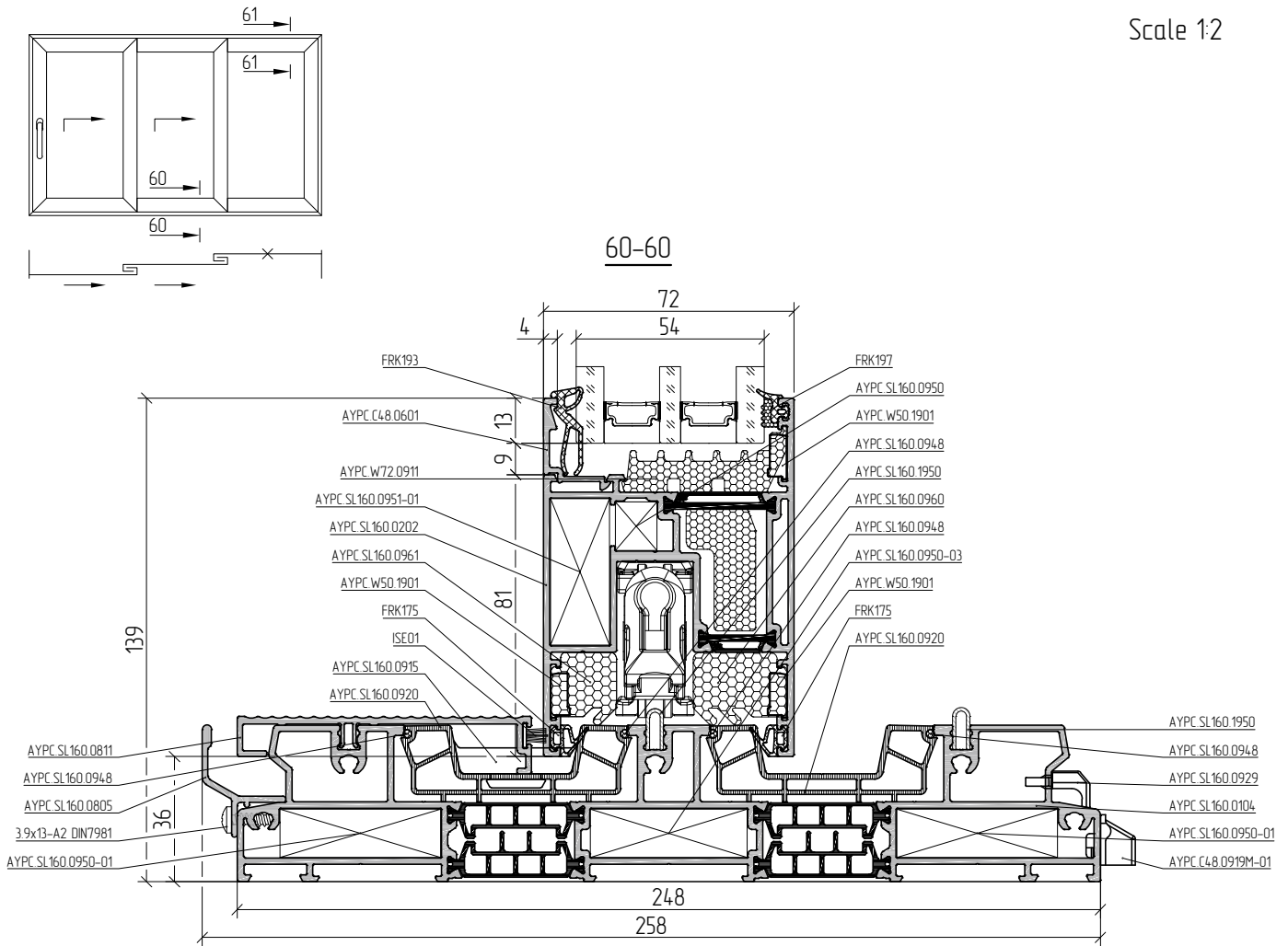

Scale 1:2

62-62

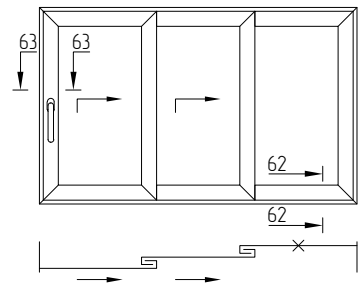
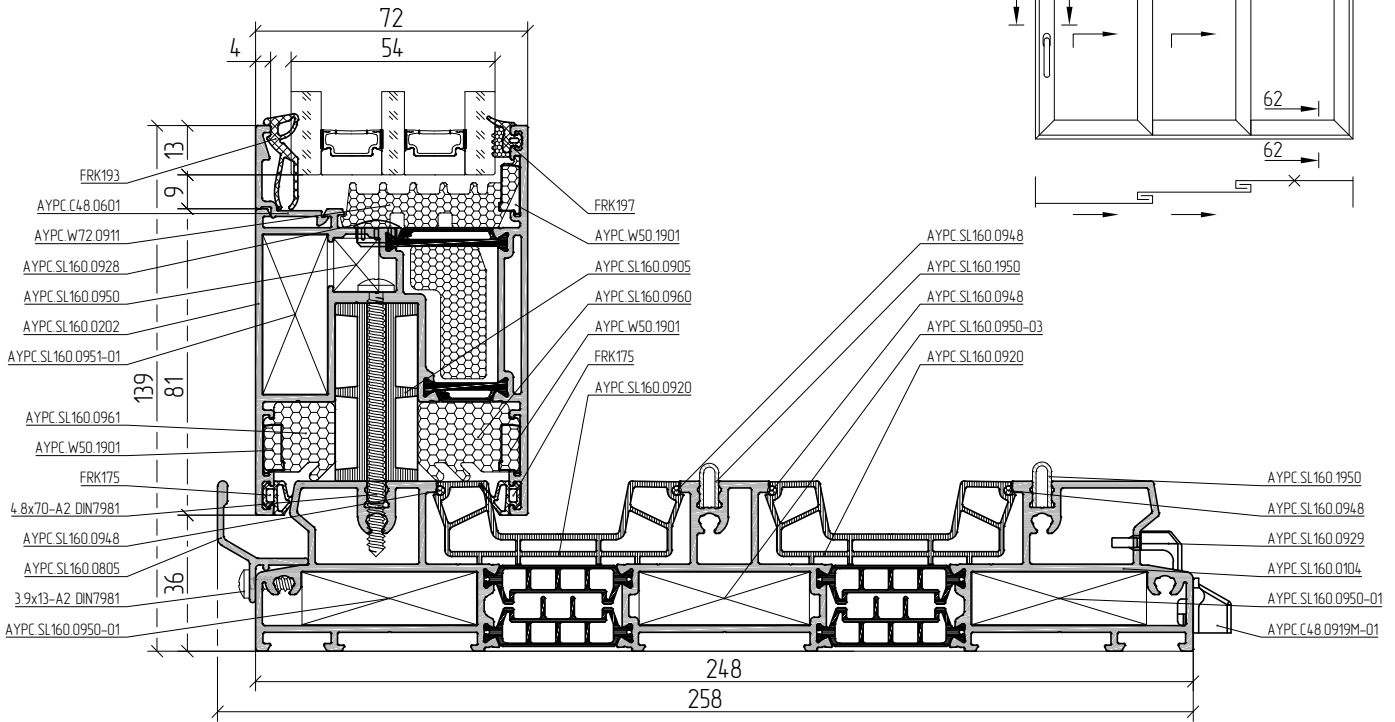

63-63

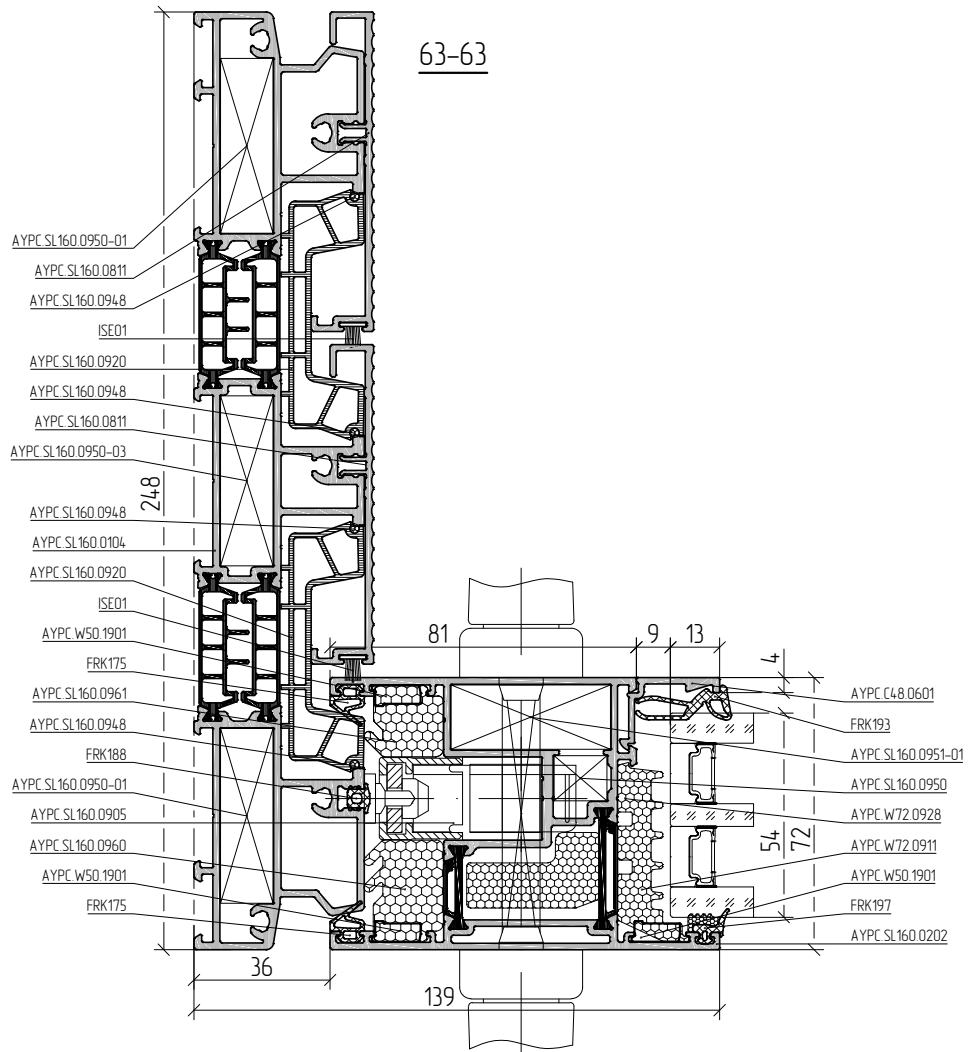

Scale 1:2

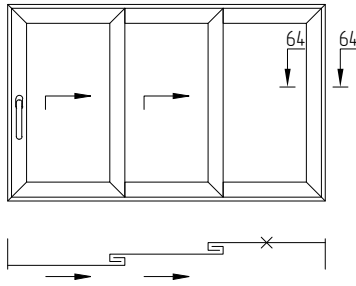

64-64

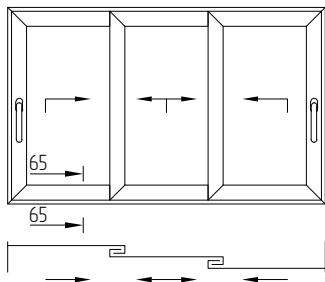
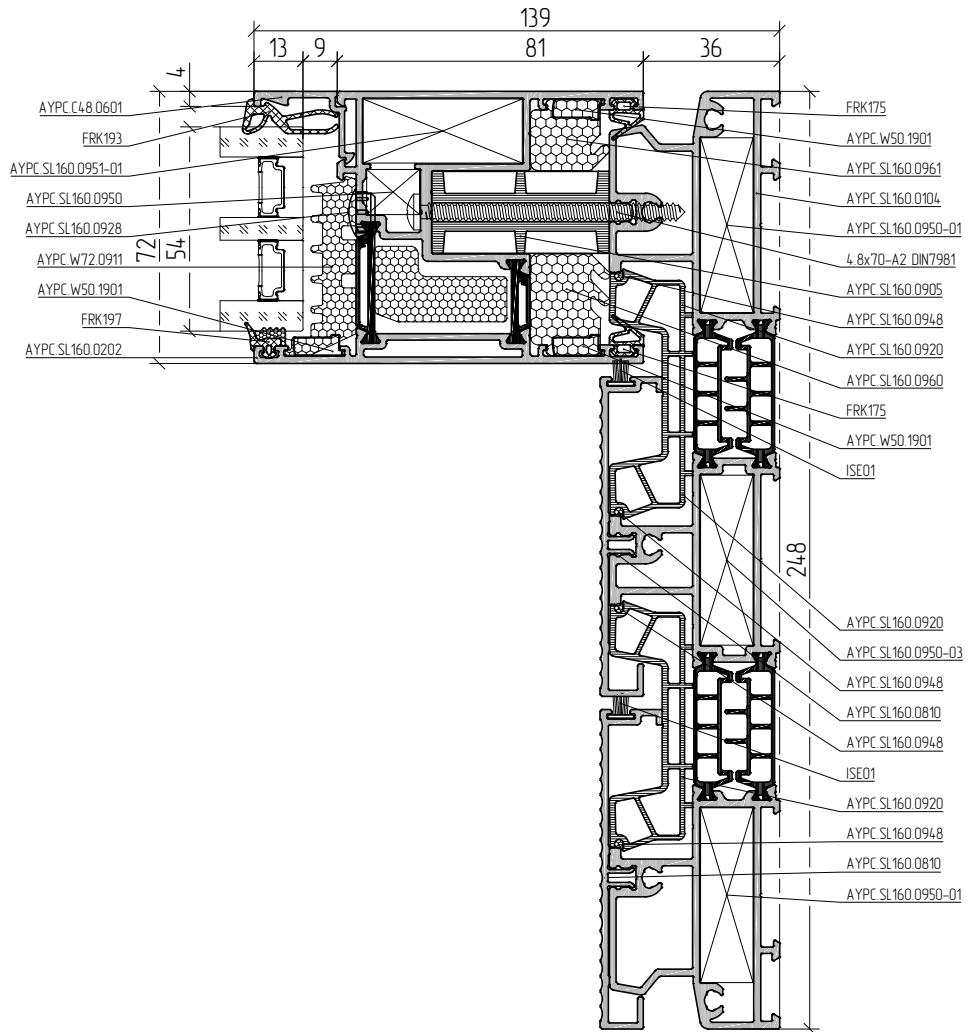

65-65

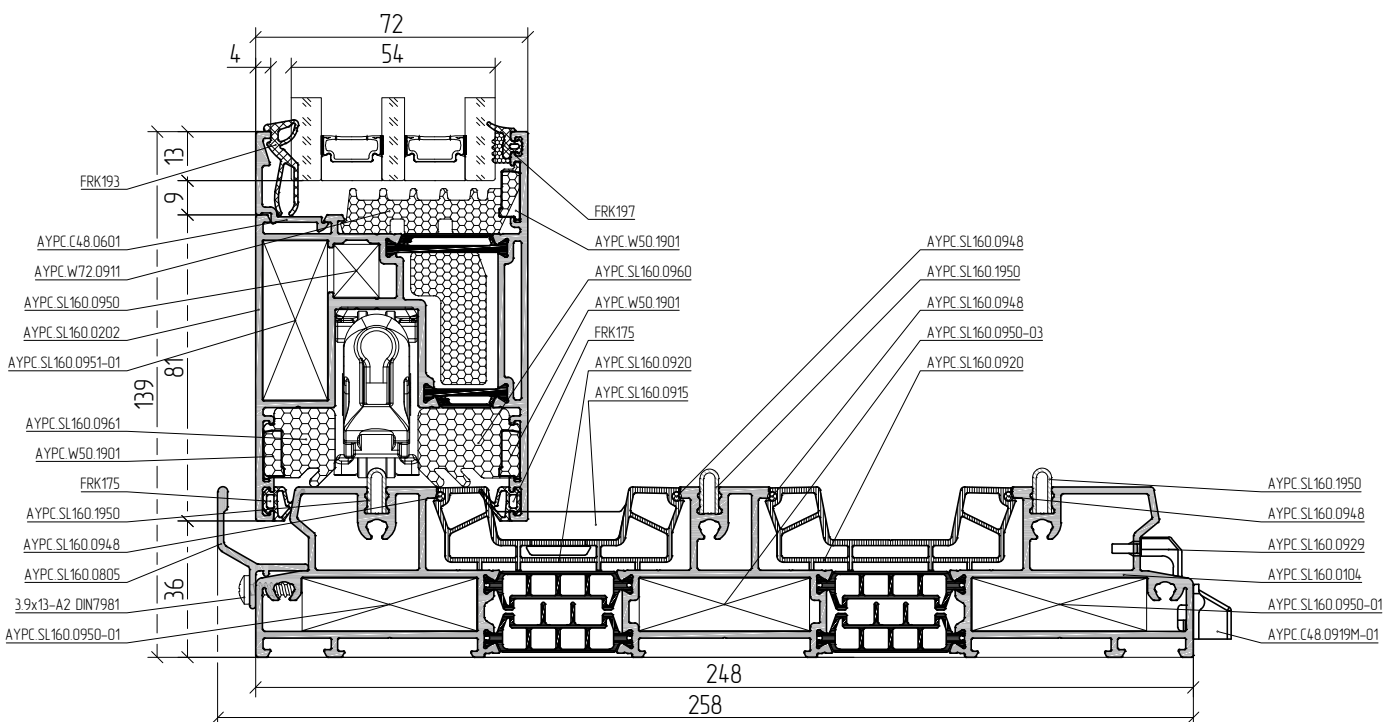

Scale 1:2

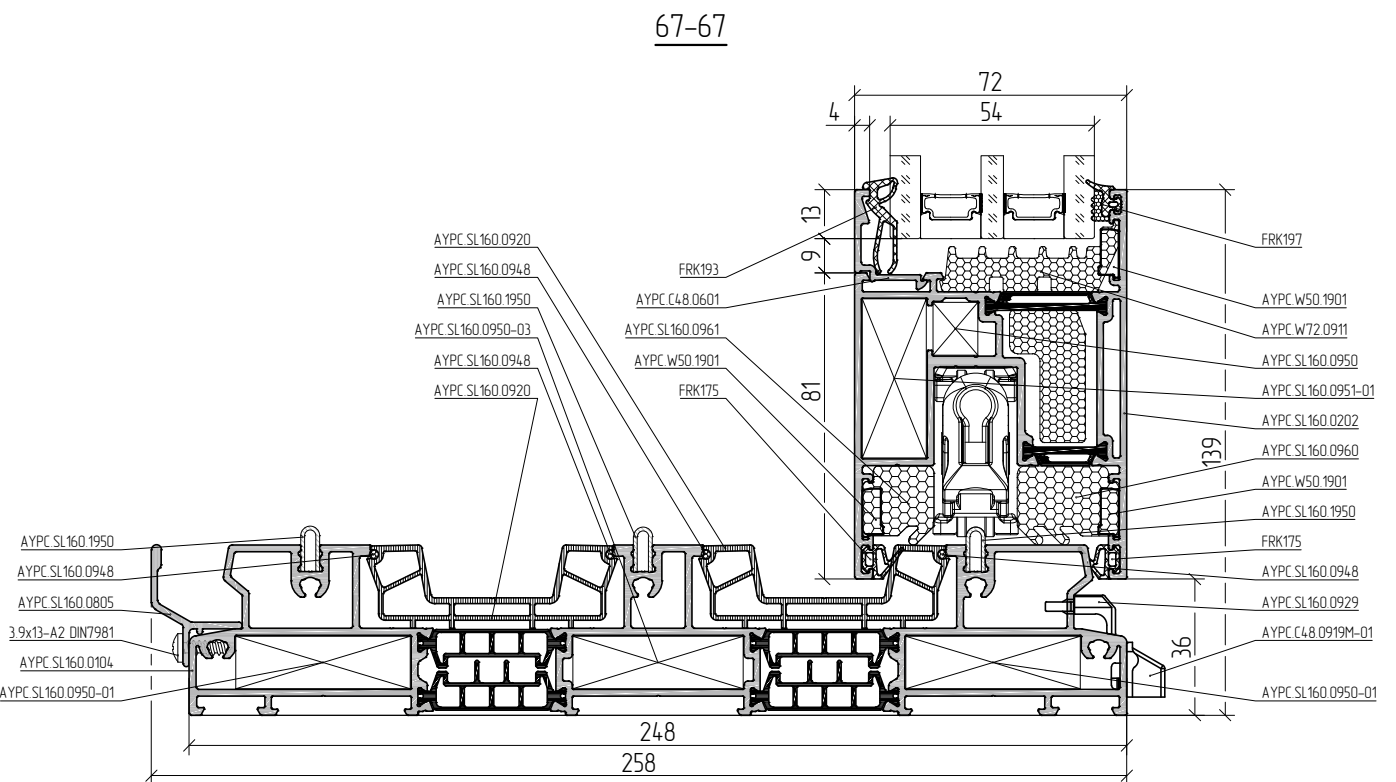
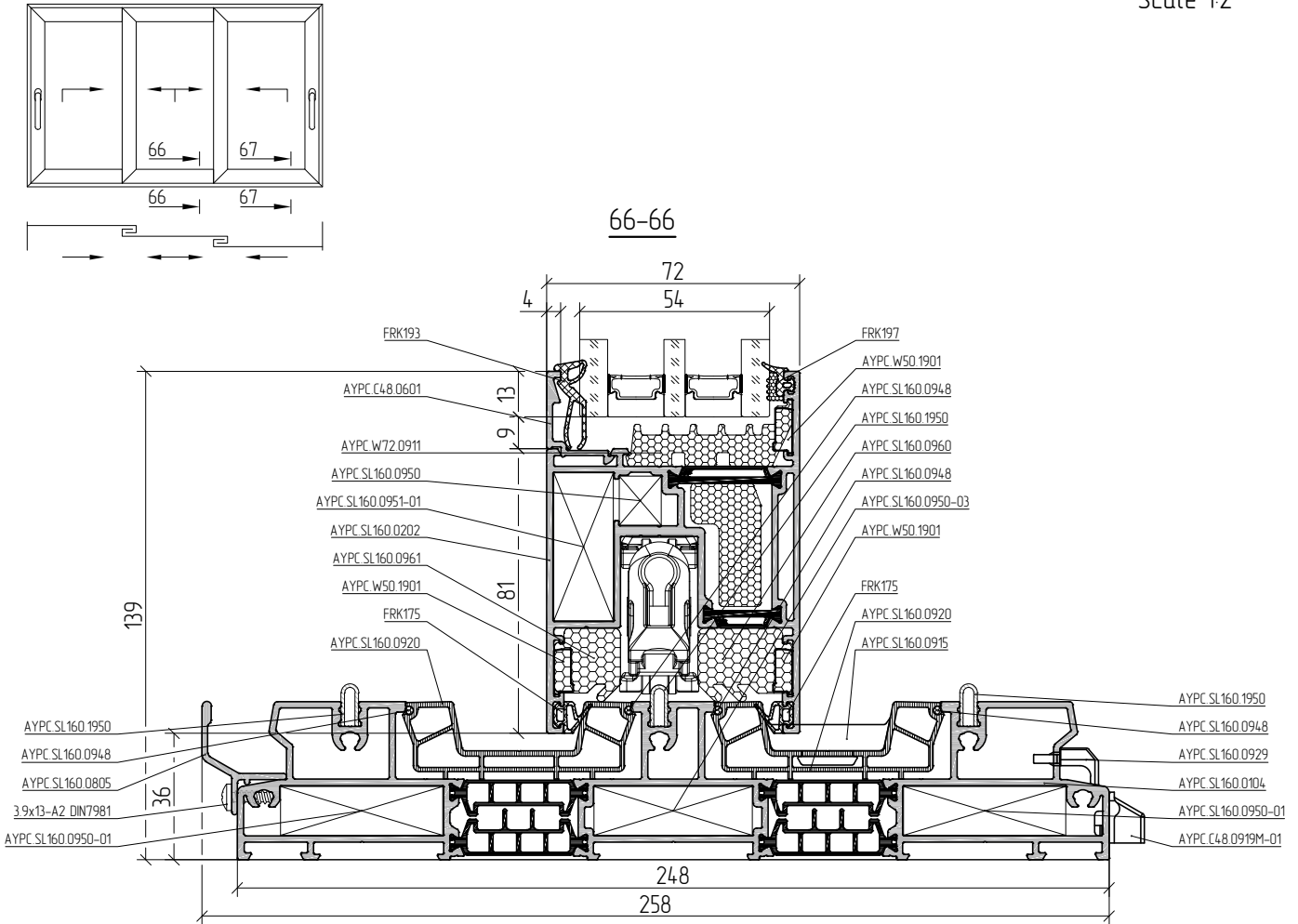

01

02

03

04

05

06

07

08

09

10

Scale 1:2

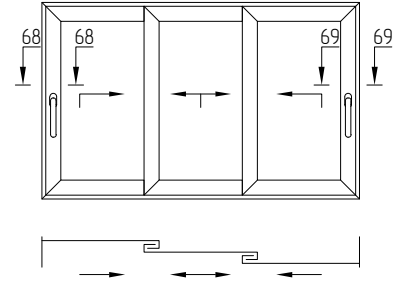

68-68

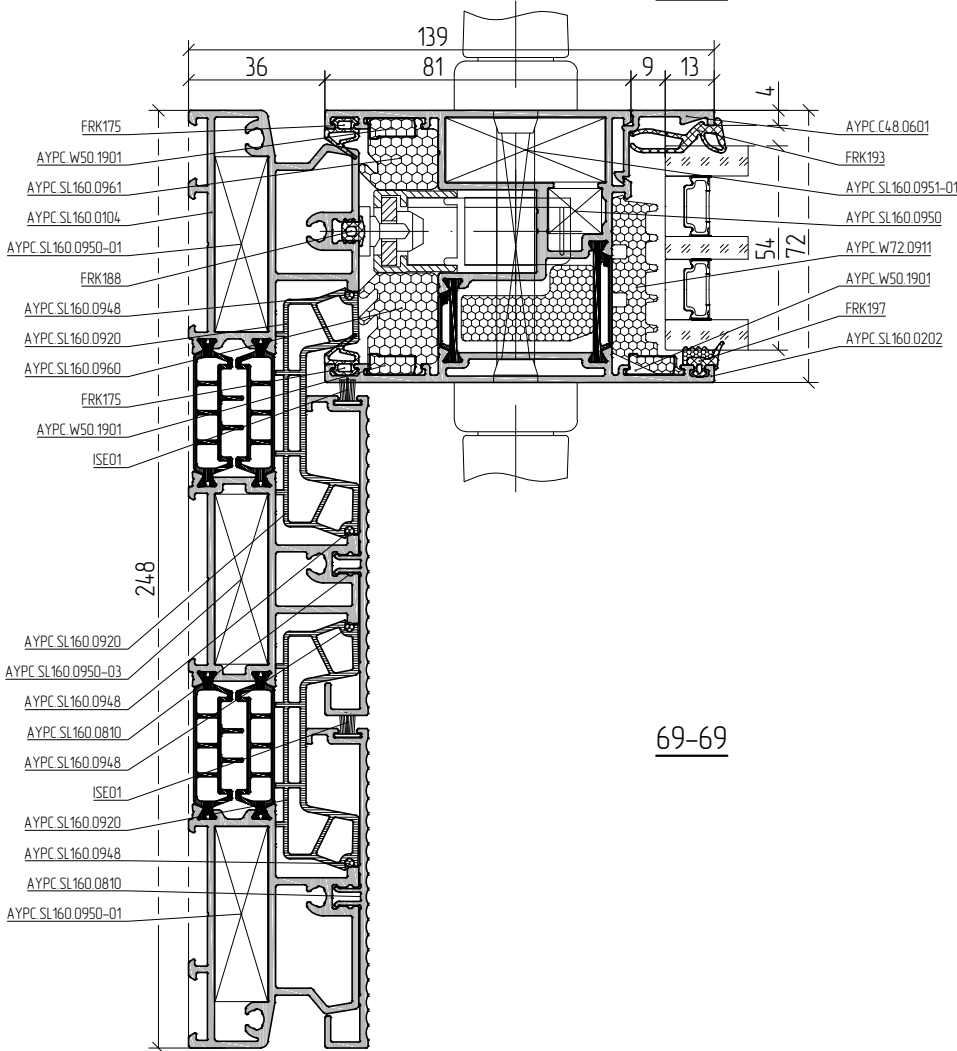

69-69

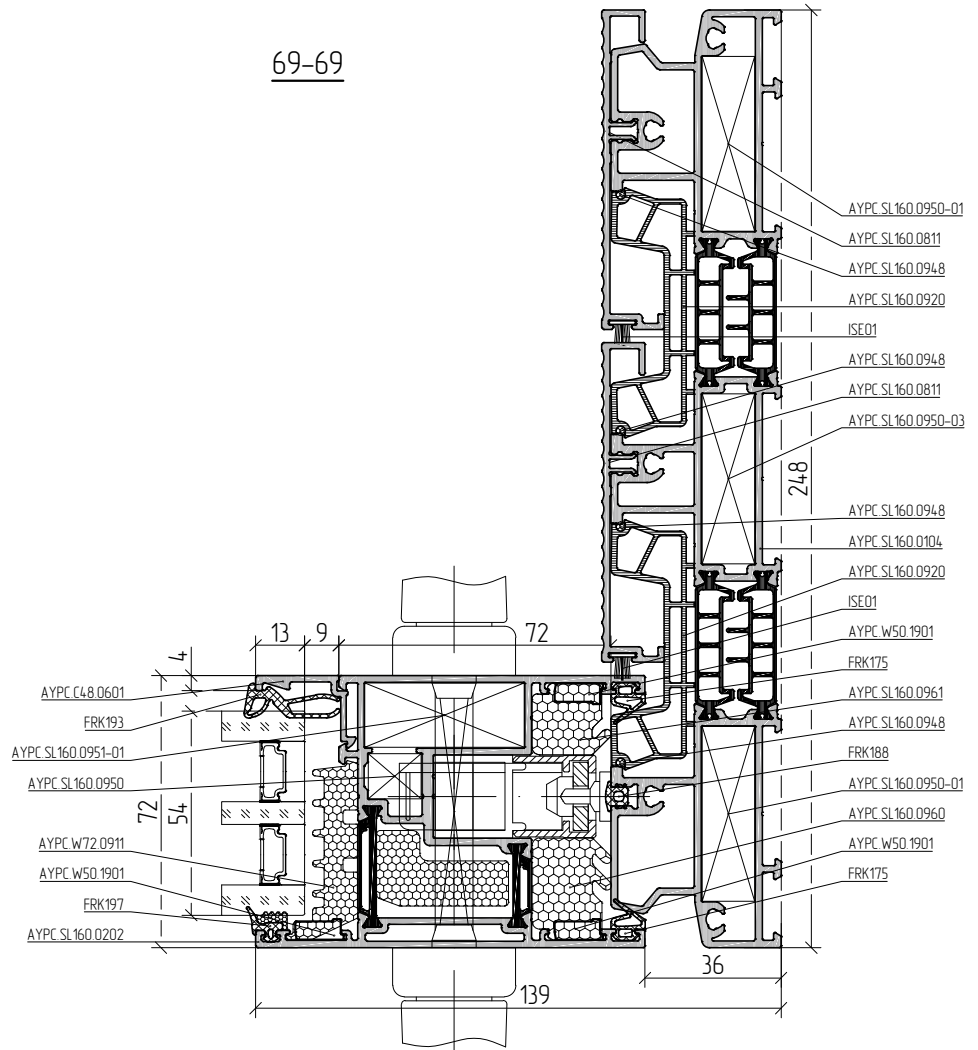

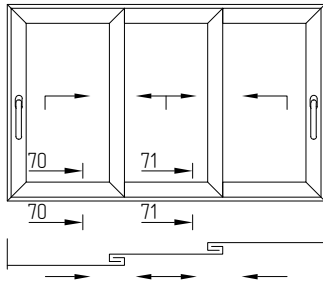

70-70

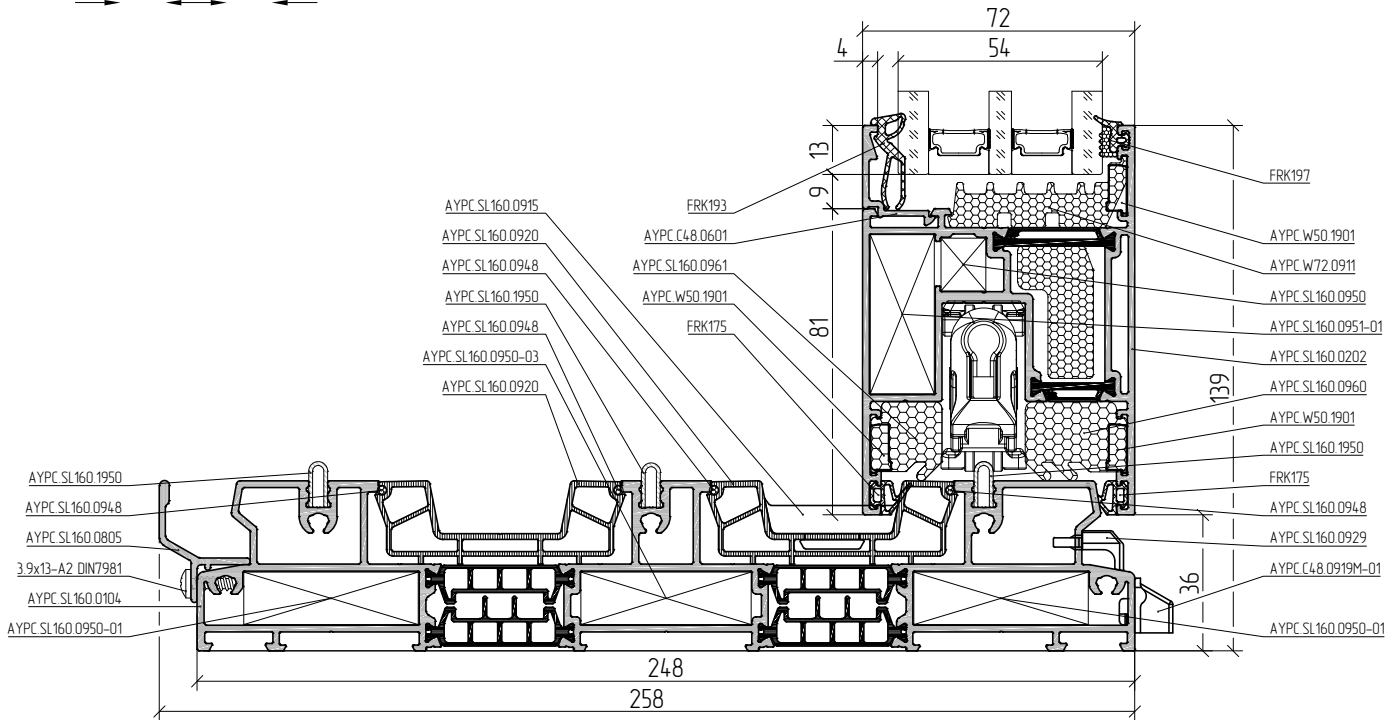

71-71

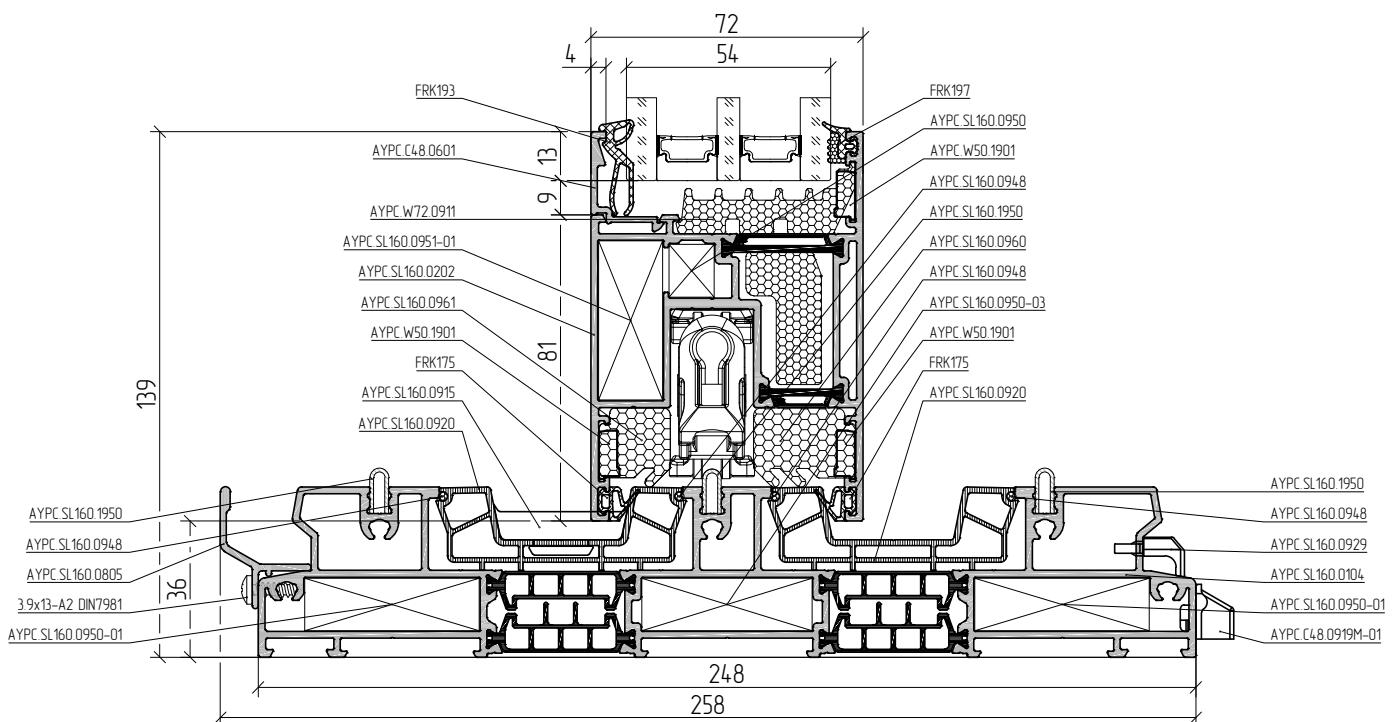

Scale 1:2

72-72

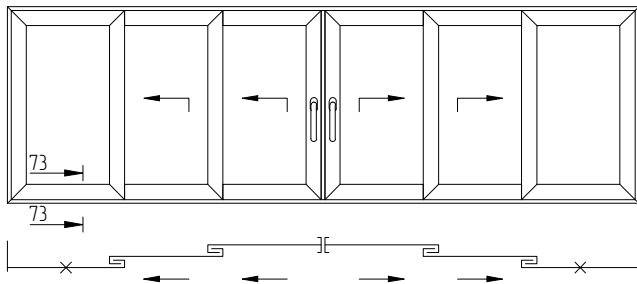
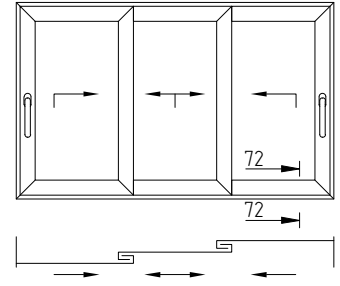
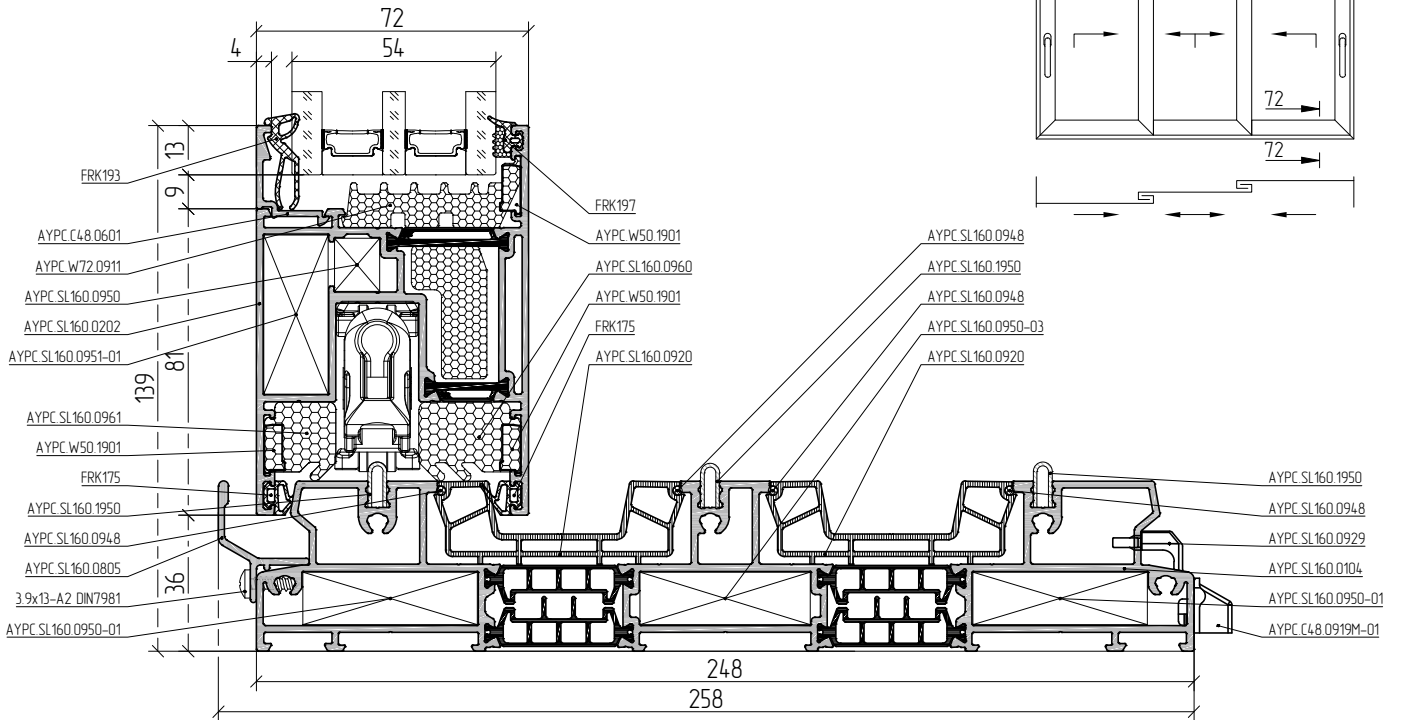

73-73

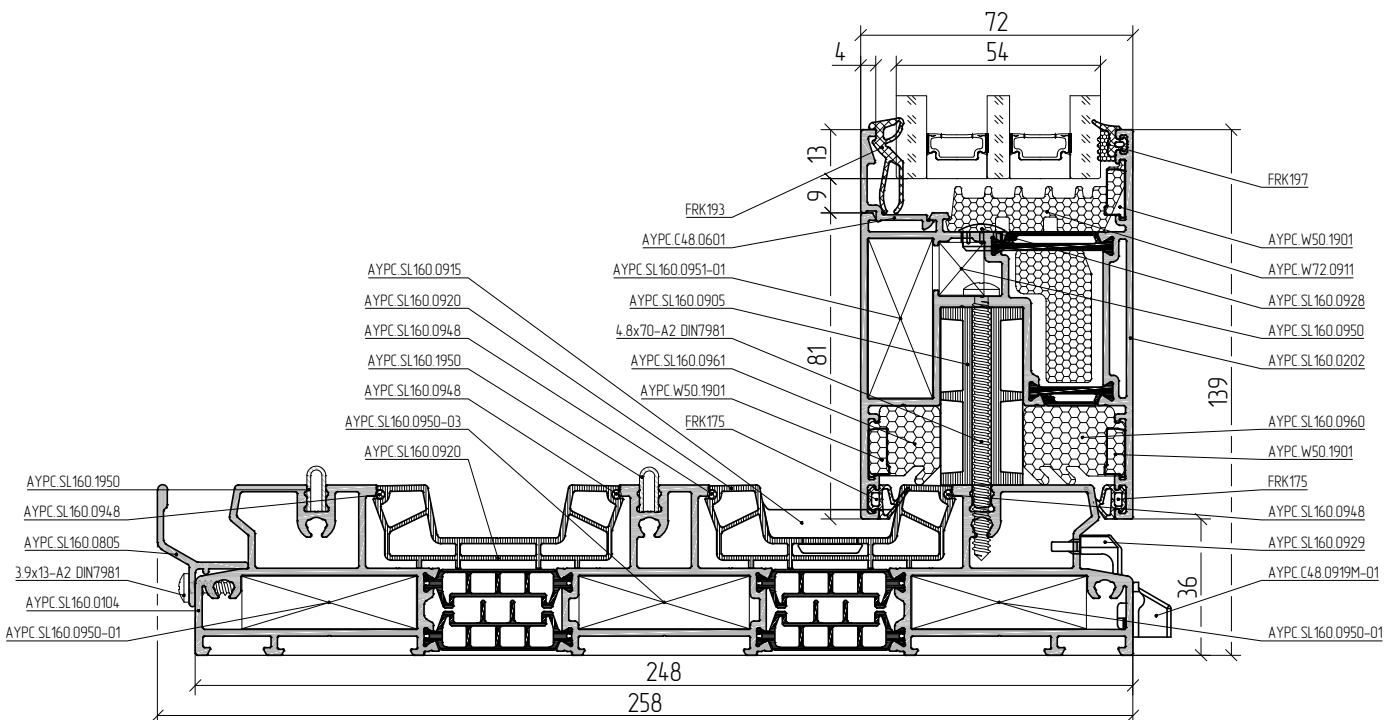

Scale 1:2

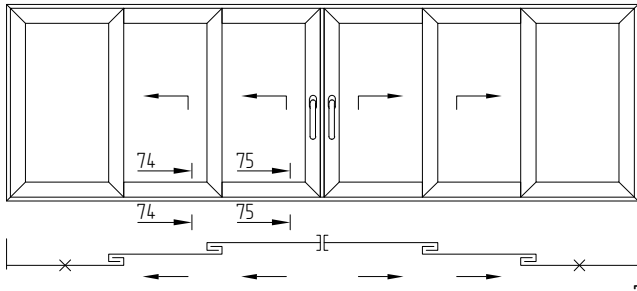

74-74

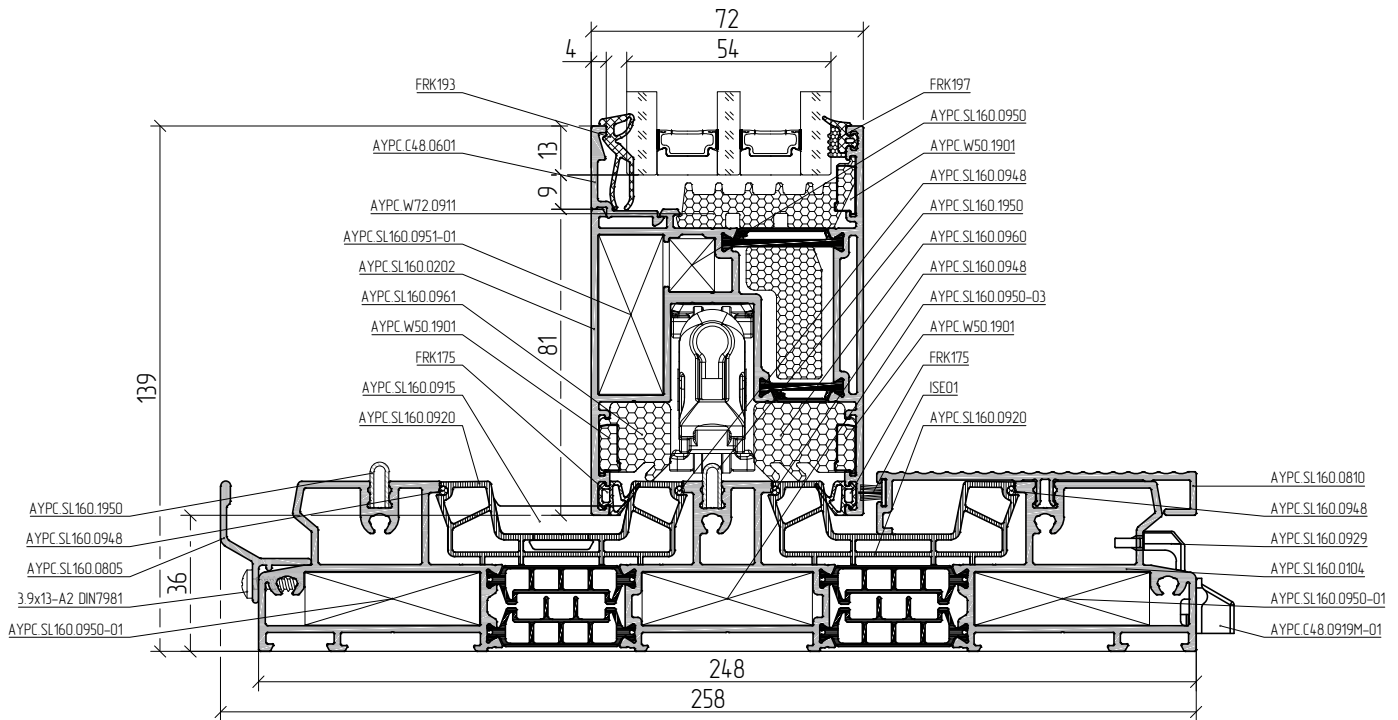

75-75

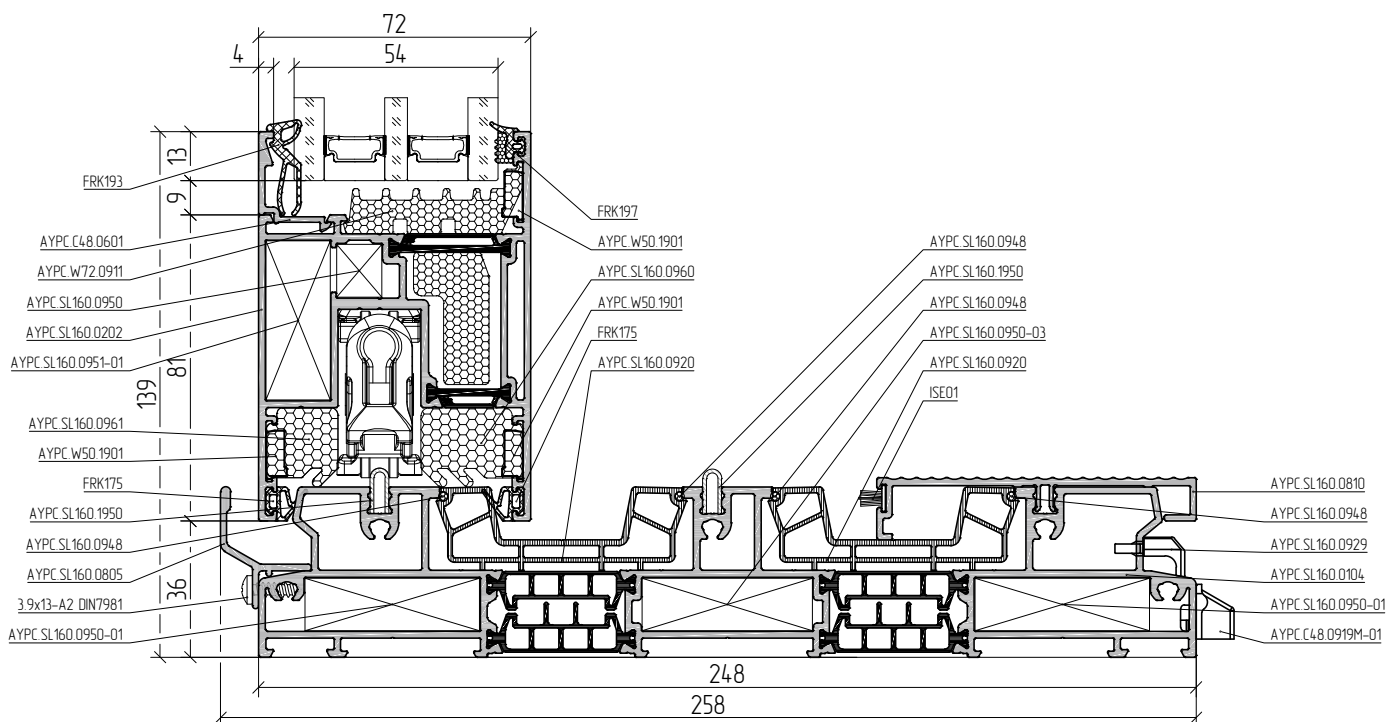

Scale 1:2

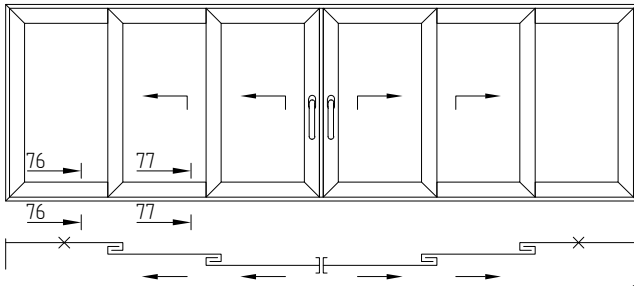

76-76

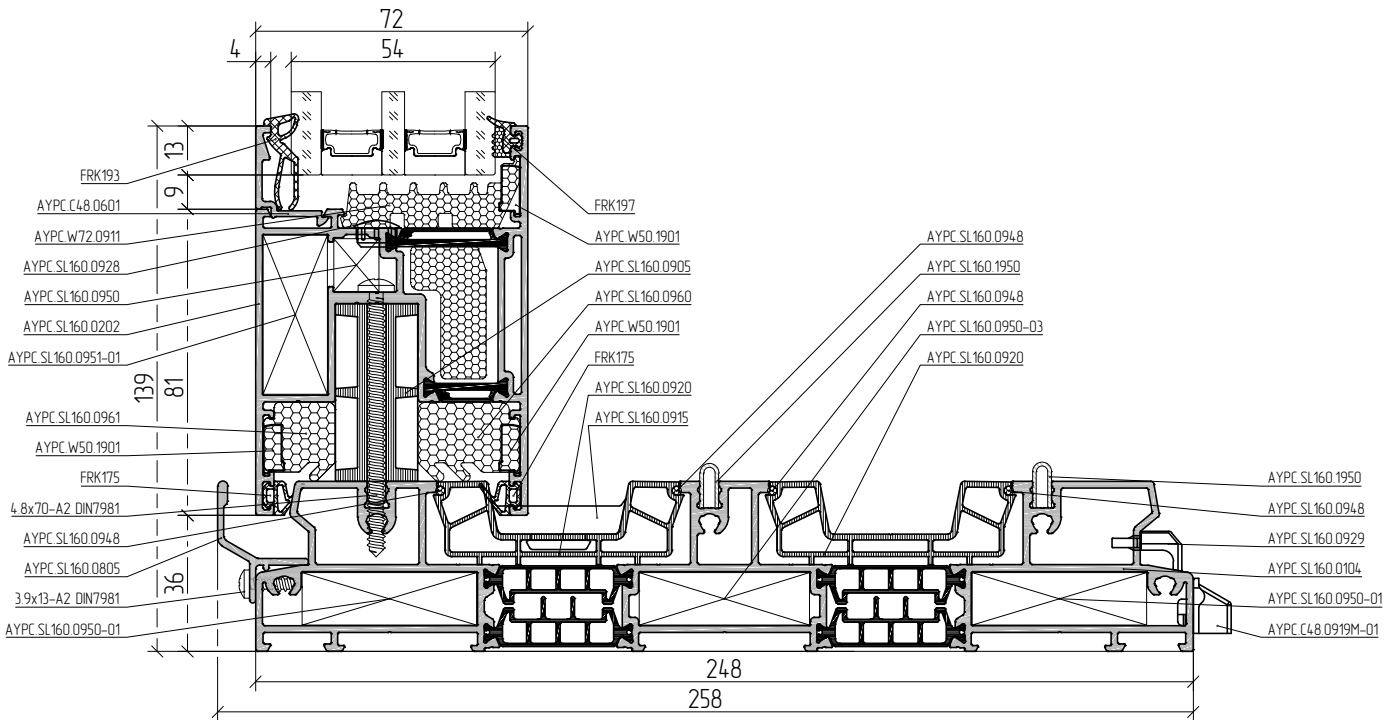

77-77

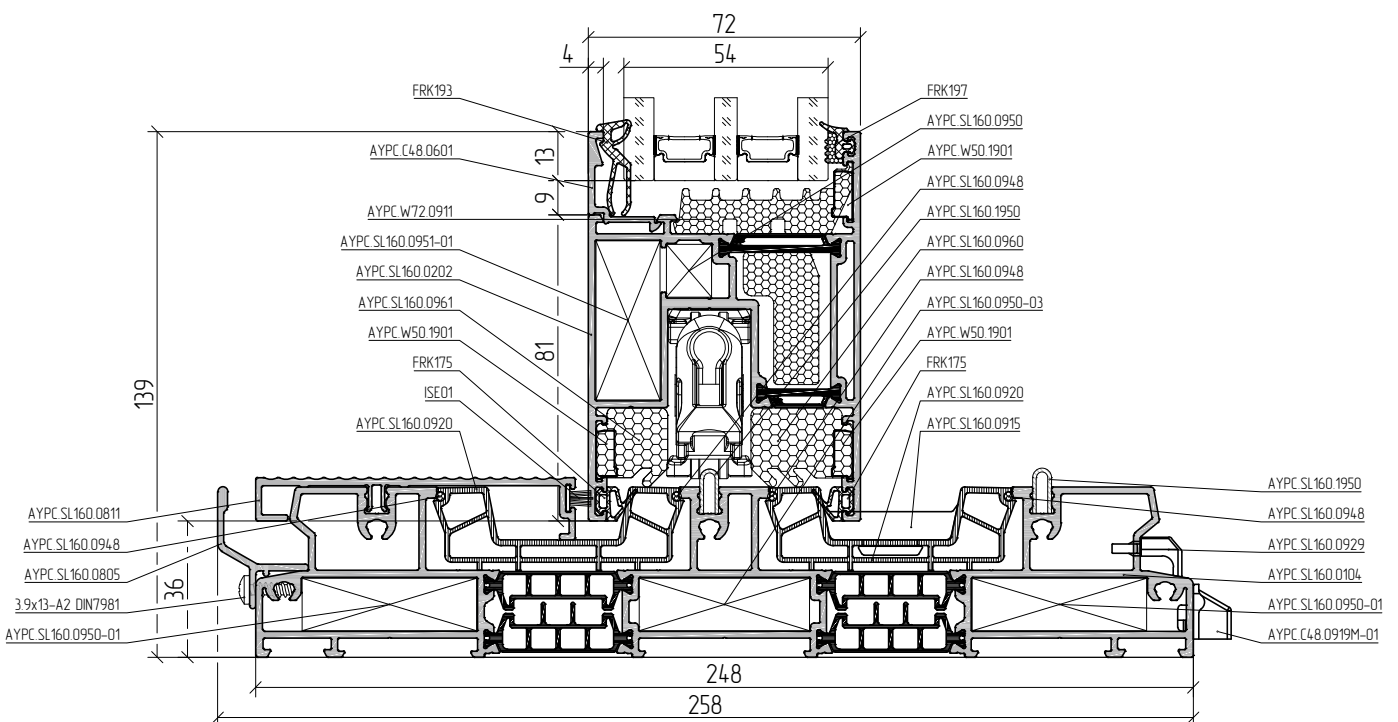

Scale 1:2

01

02

03

04

05

06

07

08

09

10

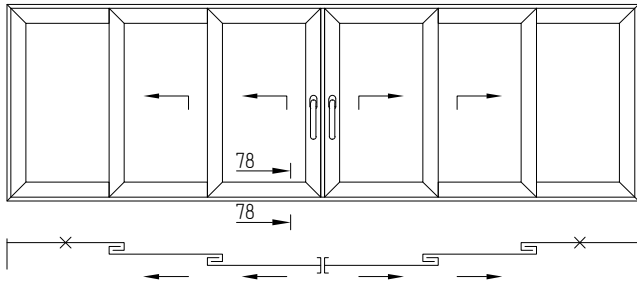

78-78

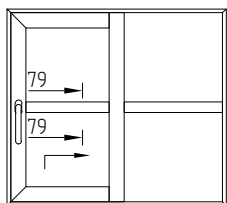
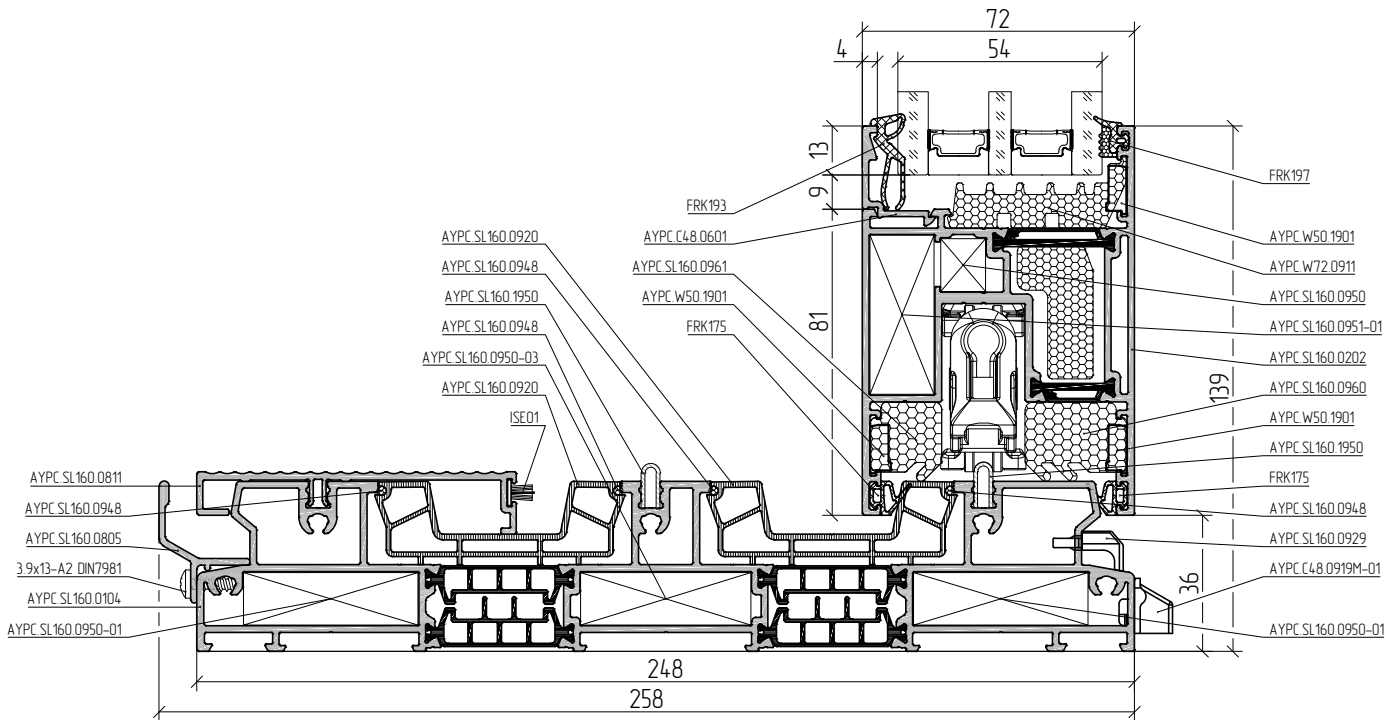

79-79

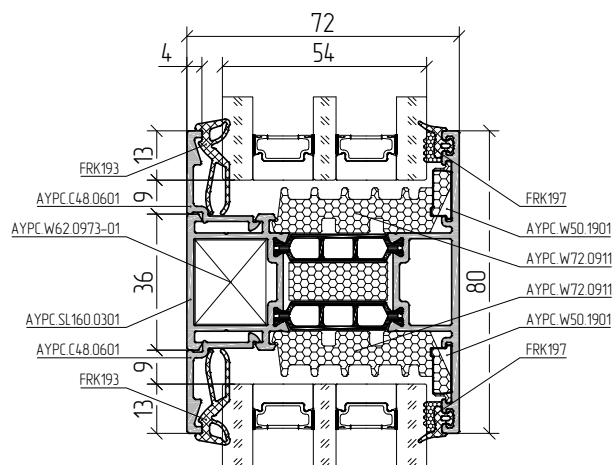

Scale 1:2

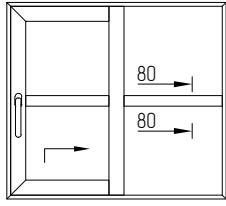

80-80

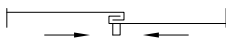
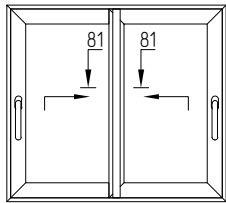
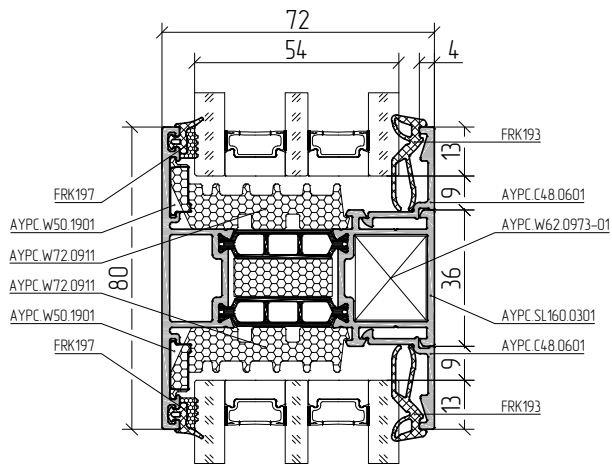

81-81

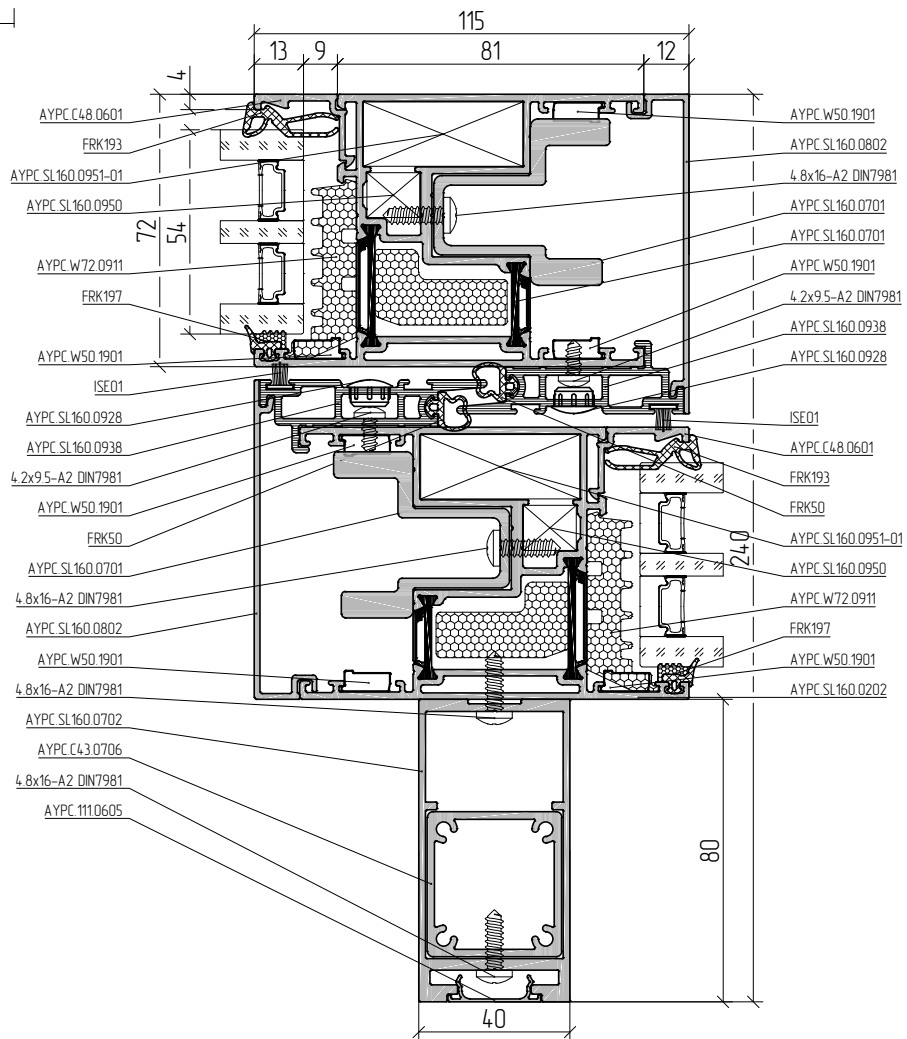

84-84

Scale 1:2

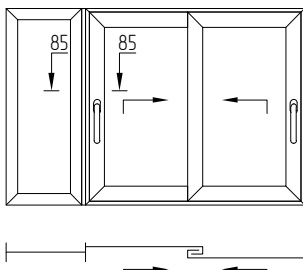
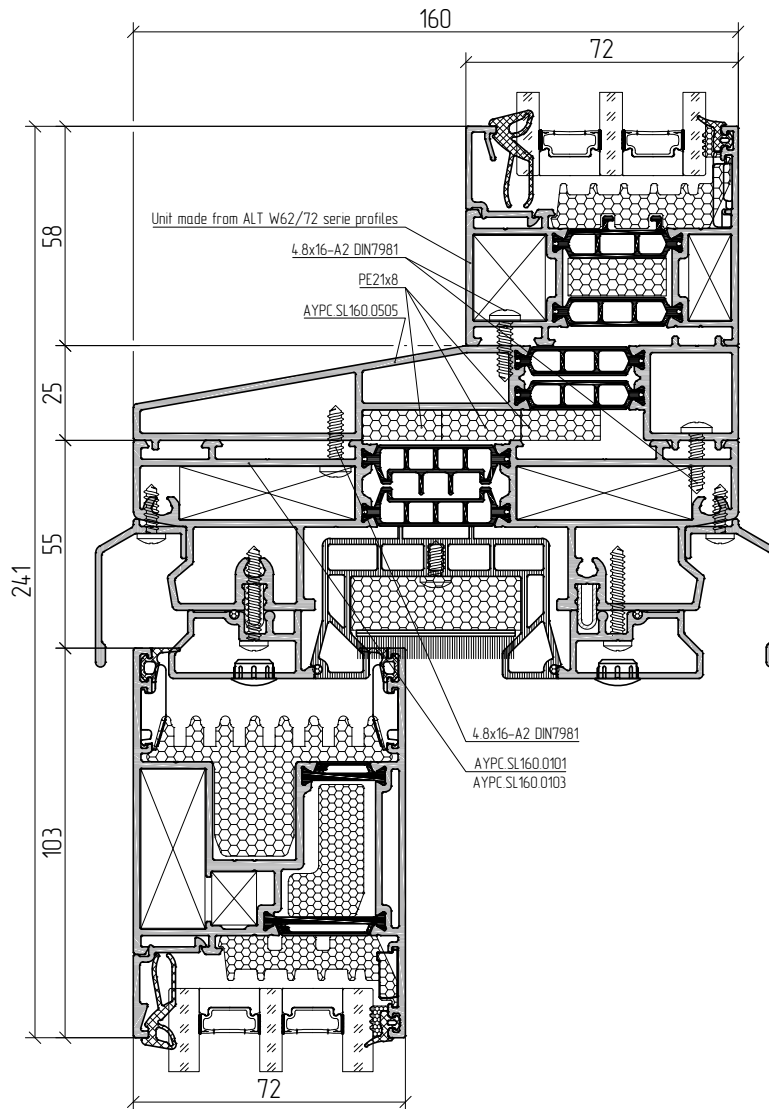
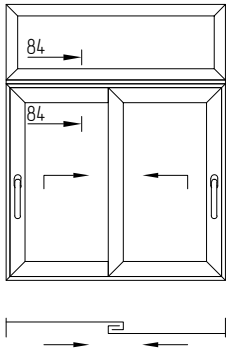

85-85

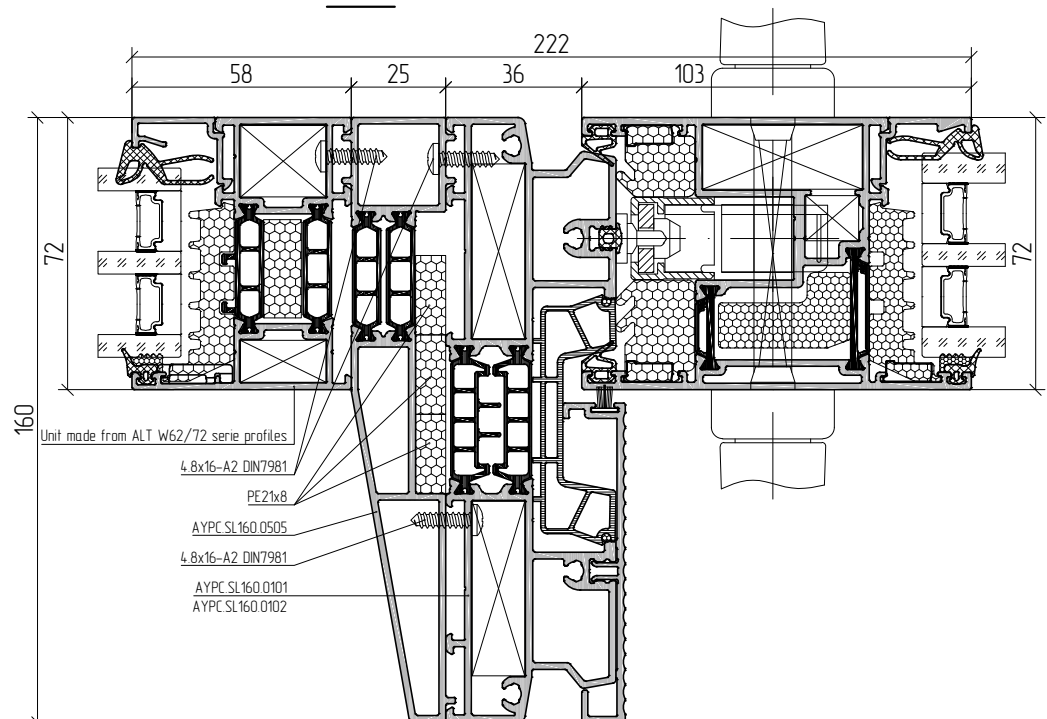

Scale 1:2

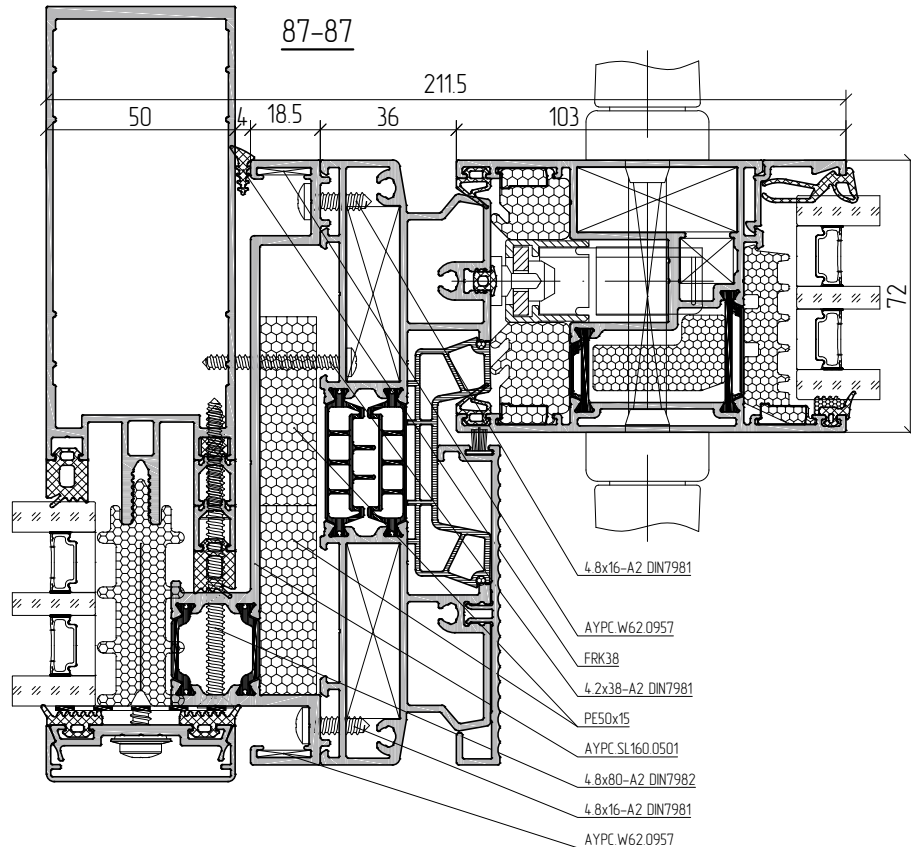
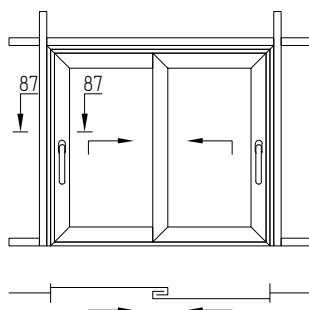
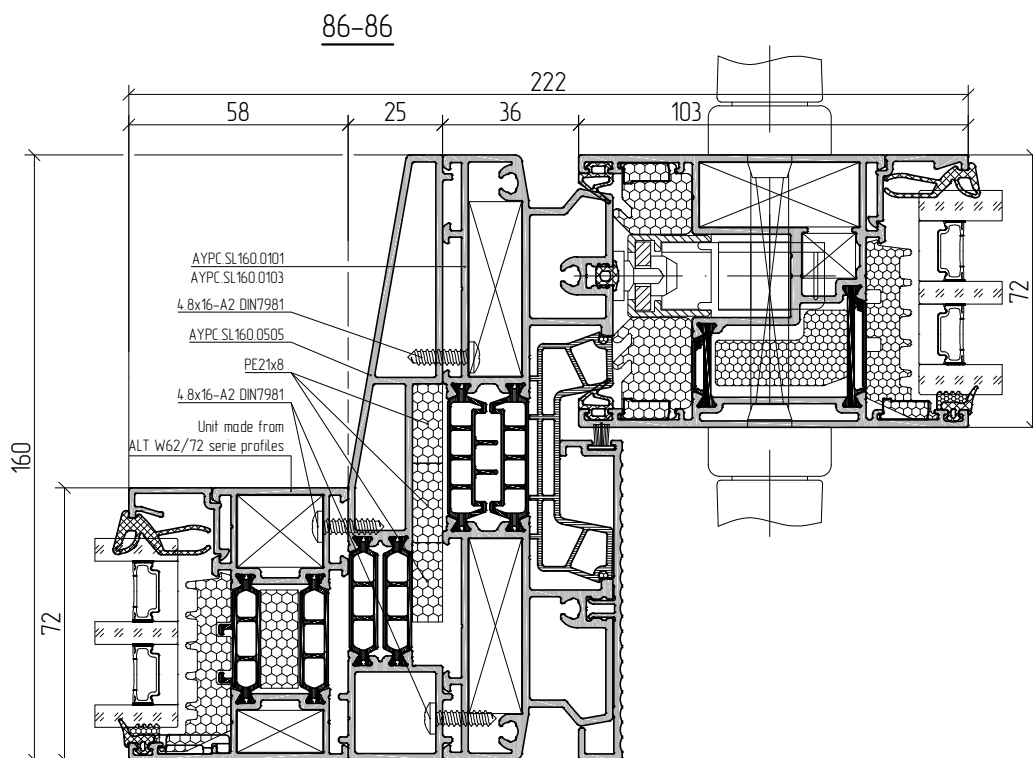
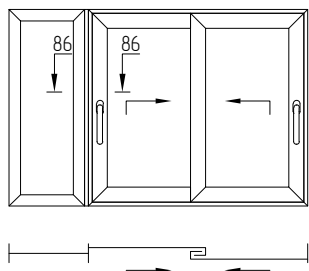

Scale 1:2

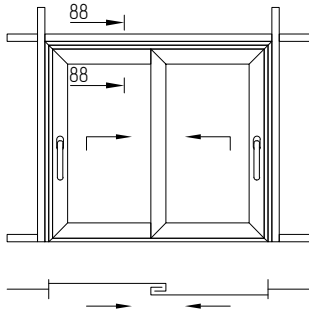

88-88

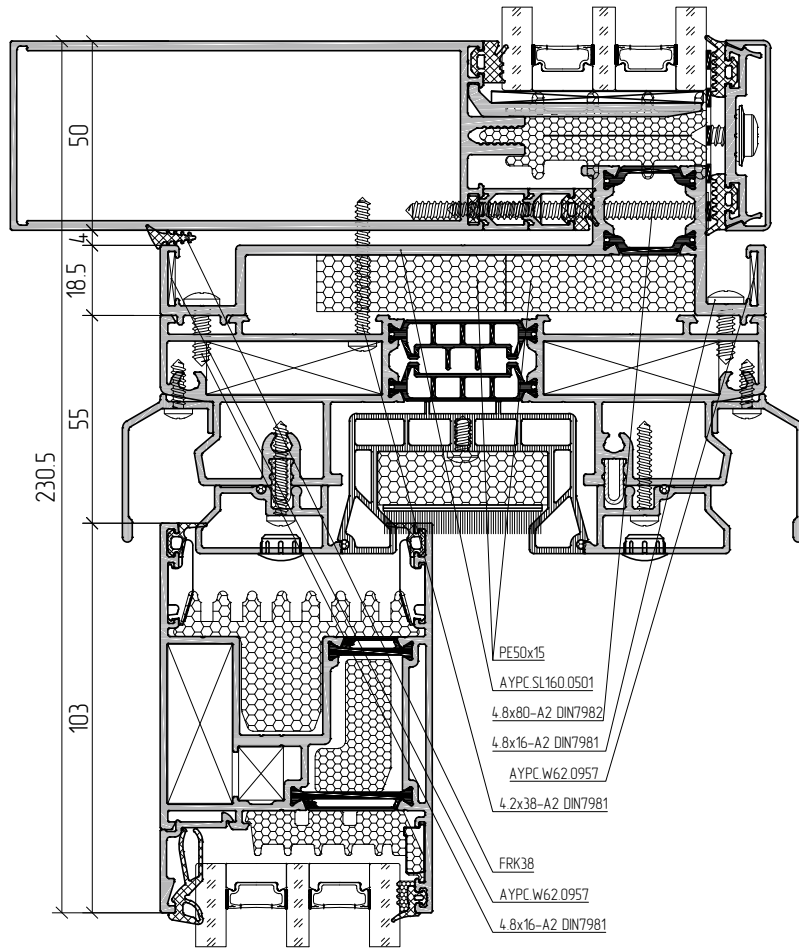

89-89

90-90

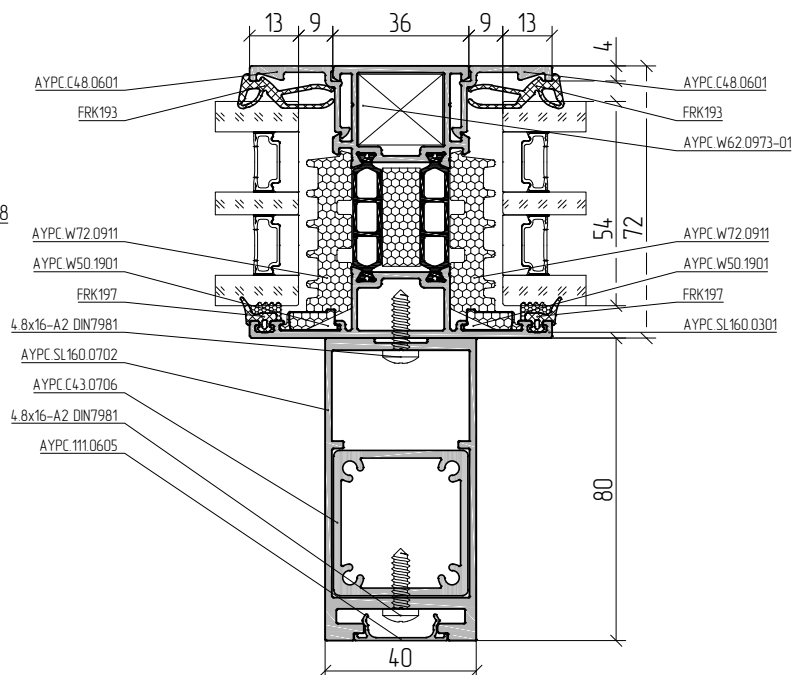
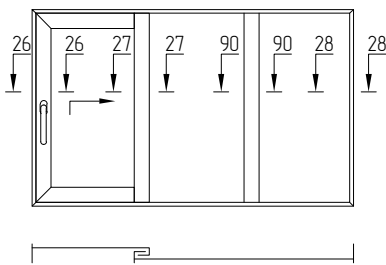
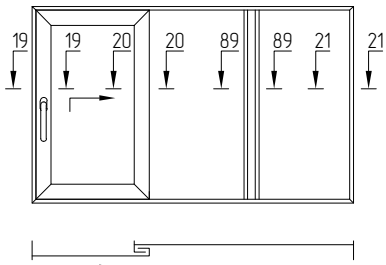

**ALUTECH ALT SL160**

Lifting and sliding
constructions

CALCULATION EXAMPLES

01

02

03

04

05

06

07

08

09

10

Example of lift and slide door calculations. A1, A2, A5, A6 types

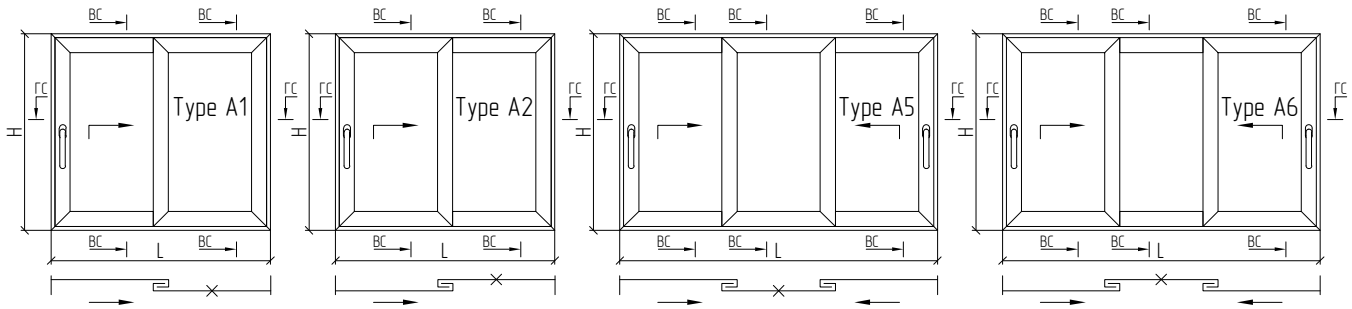

$H1/L1 < 2.5$



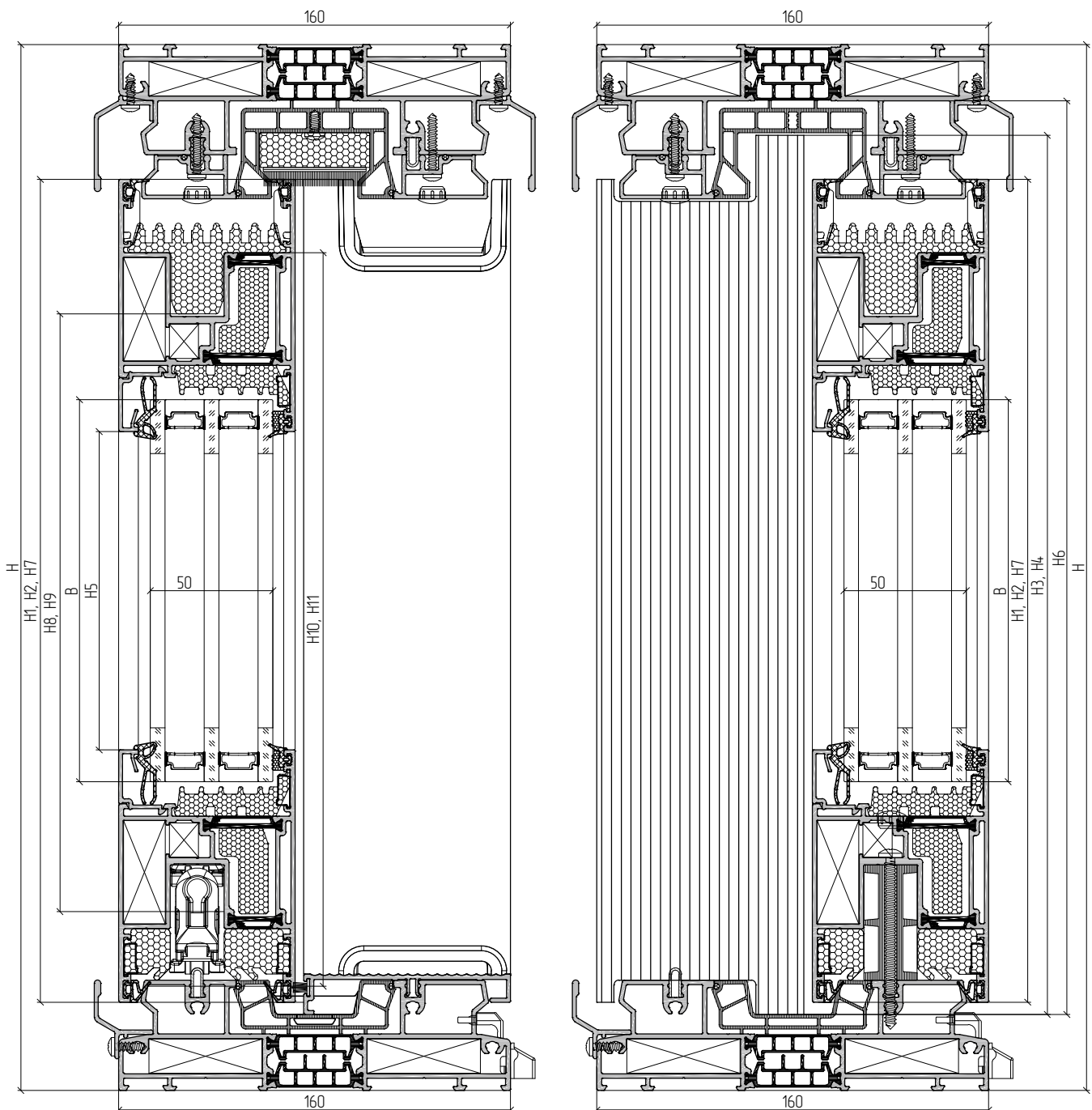





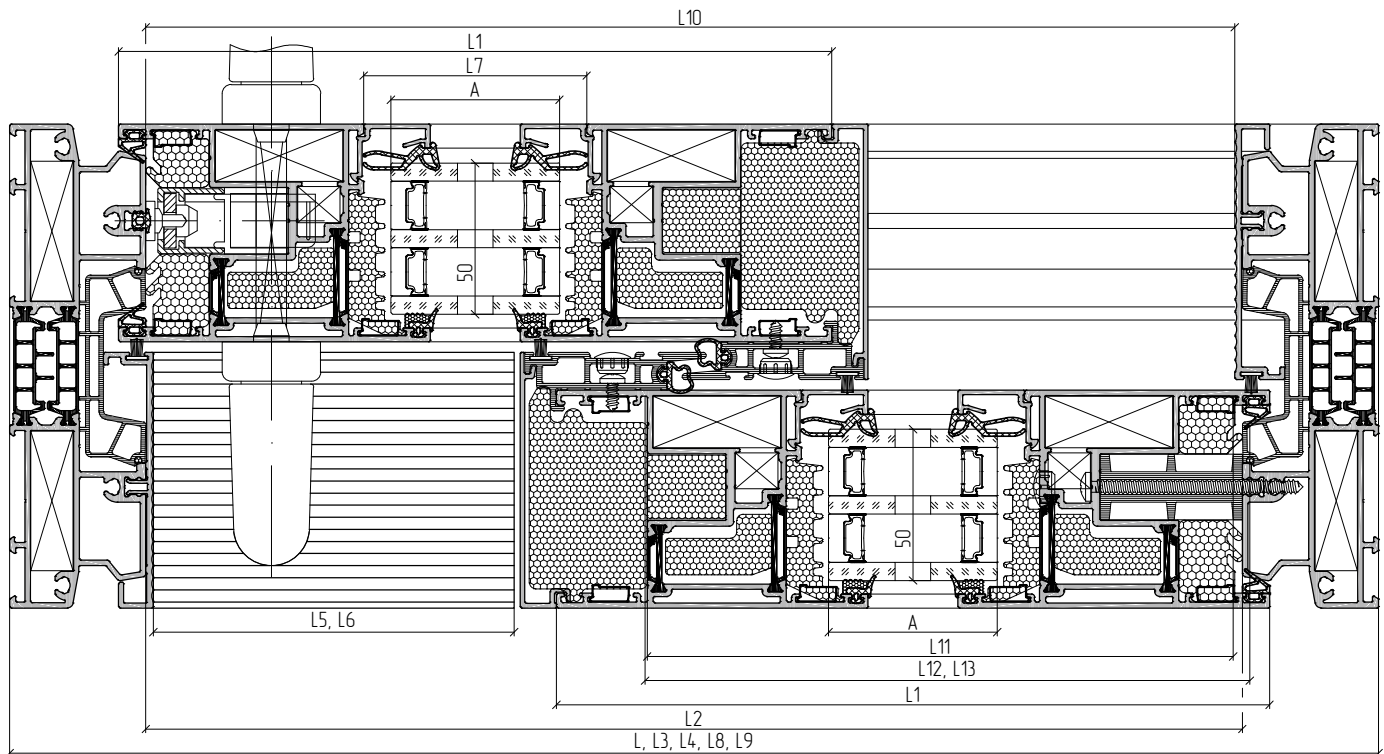

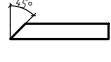
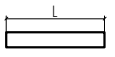



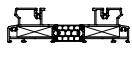
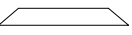
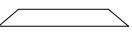

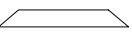
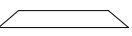

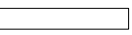

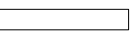
Vertical sections

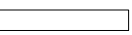

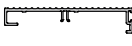
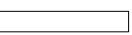
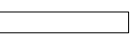
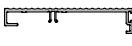
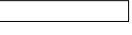
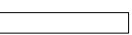

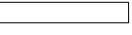
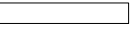





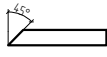
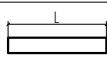
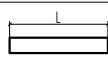
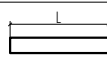
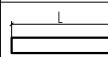

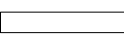

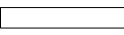

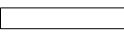

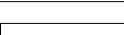



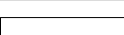



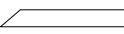
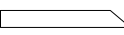



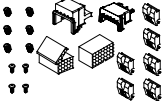
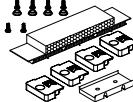

H1/L1 ≤ 25













Horizontal section









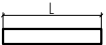
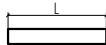
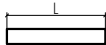
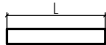

Article	Name Drawing		Type A1		Type A2		Type A5		Type A6	
				1..		1..		1..		1..
Profile										
AYPC.SL160.0101	Frame profile Double track 		L	2	L	2	L	2	L	2
			H	2	H	2	H	2	H	2
AYPC.SL160.0202	Sash profile 		L1=L/2+9.5	4	L1=L/2+9.5	4	L1=(L+110)/3	6	L1=(L+110)/3	6
			H1=H-91	4	H1=H-91	4	H1=H-91	6	H1=H-91	6
AYPC.SL160.0801	Guide rail (top) 		L2=L-90	2	L2=L-90	2	L2=L-90	2	L2=L-90	2
AYPC.SL160.0802	End profile 		H2=H1	2	H2=H1	2	H2=H1	4	H2=H1	4
AYPC.SL160.0804	Drain profile 		L3=L	2	L3=L	2	L3=L	2	L3=L	2
AYPC.SL160.0805	Drain profile 		L4=L	1	L4=L	1	L4=L	1	L4=L	1
AYPC.SL160.0810	Threshold profile Double/triple track 		L5=L/2-107	1	-	-	L5=L/3-80	2	-	-
			H3=H-68	1	H3=H-68	1	H3=H-68	2	-	-
AYPC.SL160.0811	Threshold profile Double/triple track 		-	-	L6=L/2-107	1	-	-	L6=L/3-80	2
			H4=H-68	1	H4=H-68	1	-	-	H4=H-68	2
AYPC.C48.0602	Glass bead profile 		L7=L1-162	4	L7=L1-162	4	L7=L1-162	6	L7=L1-162	6
			H5=H1-206	4	H5=H1-206	4	H5=H1-206	6	H5=H1-206	6
AYPC.SL160.0920	Drain profile 		* L8=L	1	* L8=L	1	* L8=L	1	* L8=L	1
			H6=H-54	2	H6=H-54	2	H6=H-54	2	H6=H-54	2

Article	Name Drawing		Type A1		Type A2		Type A5		Type A6	
				1...		1...		1...		1...
Profile										
AYPC.SL160.0921	Drain profile 		** L9=L	1	** L9=L	1	** L9=L	1	** L9=L	1
AYPC.SL160.0938	Interlock 		H7=H1	2	H7=H1	2	H7=H1	4	H7=H1	4
AYPC.SL160.1950	Stainless steel track 		L10=L-93	1	L10=L-93	1	L10=L-90	1	L10=L-90	1
			100	L/350	100	L/350	100	L/350	100	L/350
AYPC.SL160.0911	Foamed insert 		L11=L1-4-2	2	L11=L1-4-2	2	L11=L1-4-2	3	L11=L1-4-2	3
AYPC.SL160.0912	Foamed insert 		H8=H1-92	2	H8=H1-92	2	H8=H1-92	4	H8=H1-92	4
PE21x26	Thermal insert 		H9=H1-92	2	H9=H1-92	2	H9=H1-92	4	H9=H1-92	4
AYPC.SL160.0960	Thermal insert 		L12=L1-36	2	L12=L1-36	2	L12=L1-36	3	L12=L1-36	3
			H10=H1-36	2	H10=H1-36	2	H10=H1-36	3	H10=H1-36	3
AYPC.SL160.0961	Thermal insert 		L13=L1-36	2	L13=L1-36	2	L13=L1-36	3	L13=L1-36	3
			H11=H1-36	2	H11=H1-36	2	H11=H1-36	3	H11=H1-36	3
AYPC.W72.0911	Rebate insulation 		L14=(A+B)x2-6x100	2	L14=(A+B)x2-6x100	2	L14=(A+B)x2-6x100	3	L14=(A+B)x2-6x100	3

Article	Name Drawing	1...			
		Type A1	Type A2	Type A5	Type A6
Accessories					
AYPC.SL160.0940	Ledge kit 	2	2	4	4
AYPC.SL160.0941	Sealing block 	1	1	2	2
AYPC.SL160.0950	Corner cleat 	8	8	12	12
AYPC.SL160.0950-01	Corner cleat 	8	8	8	8
AYPC.SL160.0951-01	Corner cleat 	8	8	12	12
AYPC.W50.1901	Corner cleat 	24	24	36	36
AYPC.SL160.0905	Fixator 	4	4	2	2
AYPC.SL160.0928	Decorative plug 	L2/250+ H7/150+4	L2/250+ H7/150+4	L2/250+ H7/150+2	L2/250+ H7/150+2
AYPC.SL160.0943	Encapsulating insert 	2	2	2	2
AYPC.SL160.0945	Encapsulating insert 	2	2	2	2
AYPC.SL160.0946	Encapsulating insert 	4	4	4	4
AYPC.SL160.0949	Bearing support 	12	12	18	18
100x56x1(3)	Leveling support 	12(12)	12(12)	18(18)	18(18)

Article	Name Drawing		1...			
			Type A1	Type A2	Type A5	Type A6
Accessories						
AYPC.SL160.0929	Water drain plug		L/500	L/500	L/500	L/500
AYPC.C48.0919M-01	Water drain plug		2	2	2	2
FRK177	Rubber corner		8	8	12	12
FRK178	Rubber corner		4	4	6	6
FRK178-01	Rubber corner		4	4	6	6
FRK179	Rubber corner		8	8	12	12
Hardware						
3.9x13-A2 DIN7981	Self-tapping screw		L3/100	L3/100	L3/100	L3/100
3.9x13-A2 DIN7982	Self-tapping screw		32	32	40	40
3.9x25-A2 DIN7981	Self-tapping screw		L2/250	L2/250	L2/250	L2/250
4.2x9.5-A2 DIN7981	Self-tapping screw		H7/150	H7/150	H7/75	H7/75
4.8x32-A2 DIN7981	Self-tapping screw		8	8	4	4
4.8x70-A2 DIN7981	Self-tapping screw		4	4	2	2
5x10 DIN6325D	Pin		16	16	24	24

Article	Name Drawing		Type A1		Type A2		Type A5		Type A6	
				1...		1...		1...		1...
Gaskets										
FRK50	Gasket		H7	2	H7	2	H7	4	H7	4
FRK175	Rebate gasket		L1x2+H1x2	2	L1x2+H1x2	2	L1x3+H1x2	2	L1x3+H1x2	2
FRK176	Gasket		L1x2	2	L1x2	2	L1x2	3	L1x2	3
FRK188	Gasket		H1	1	H1	1	H1	2	H1	2
FRK193	Wedge gasket		(A+B)x2	2	(A+B)x2	2	(A+B)x2	3	(A+B)x2	3
FRK197	Outside gasket		(A+B)x2	2	(A+B)x2	2	(A+B)x2	3	(A+B)x2	3
AYPC.SL160.0948	Sealing cord		L2x2+H6x4+L8x2+L9x2	1	L2x2+H6x4+L8x2+L9x2	1	L2x2+H6x4+L8x2+L9x2	1	L2x2+H6x4+L8x2+L9x2	1
ISE01	Felt sealing		H3+L5+H4+H7x2	1	H3+H4+L6+H7x2	1	H3x2+L5x2+H7x4	1	H4x2+L6x2+H7x4	1

Infill									
Type A1		Type A2		Type A5		Type A6			
A=L1-180, B=H1-180	2	A=L1-180, B=H1-180	2	A=L1-180, B=H1-180	3	A=L1-180, B=H1-180	3		

1. When manufacturing A5 and A6 type doors with the width of 6500 mm it is necessary to install additional frame connectors and encapsulating inserts. (see page 08.52).

2. Select glass bead profile and rubber gaskets according to the infill thickness (see the section 05 – Glazing table).

* The length of AYPC.SL160.0920 profile is given for calculation of quantity. See dimensions and cutting on page 08.09.

** The length of AYPC.SL160.0921 profile is given for calculation of quantity. See dimensions and cutting on page 08.28.



Example of lift and slide door calculations. Type A4

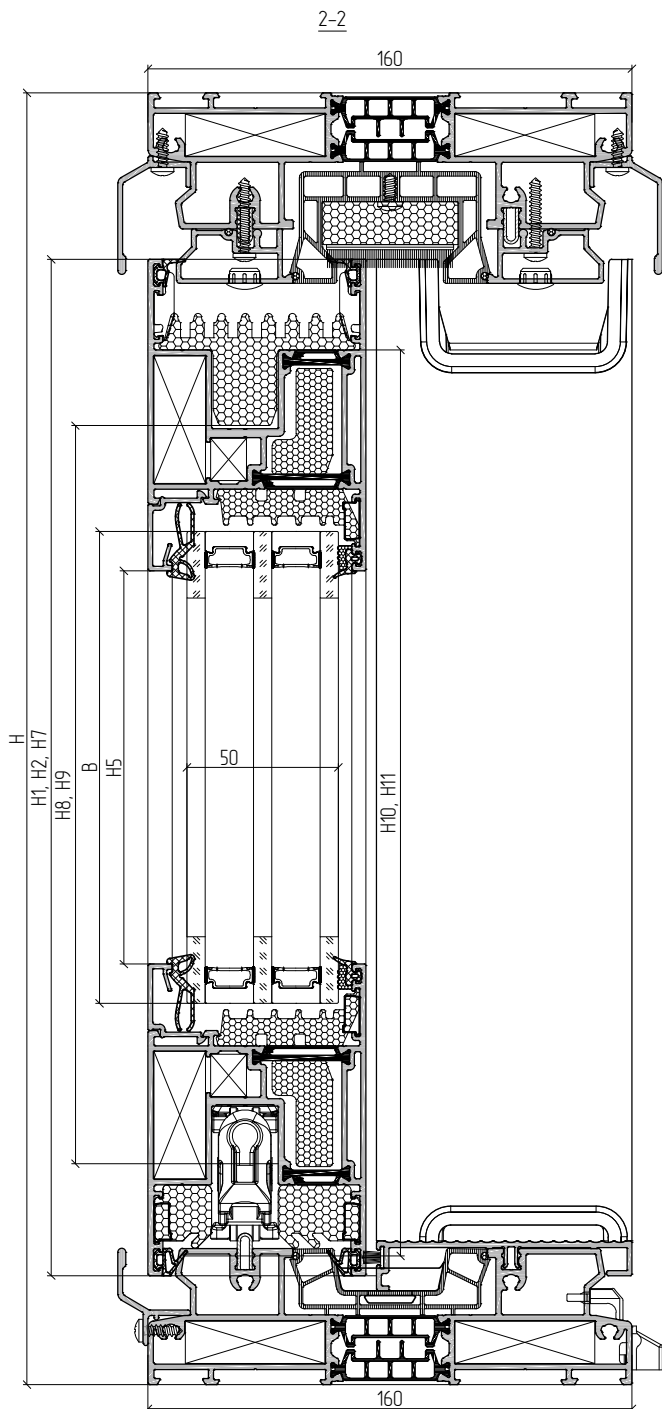
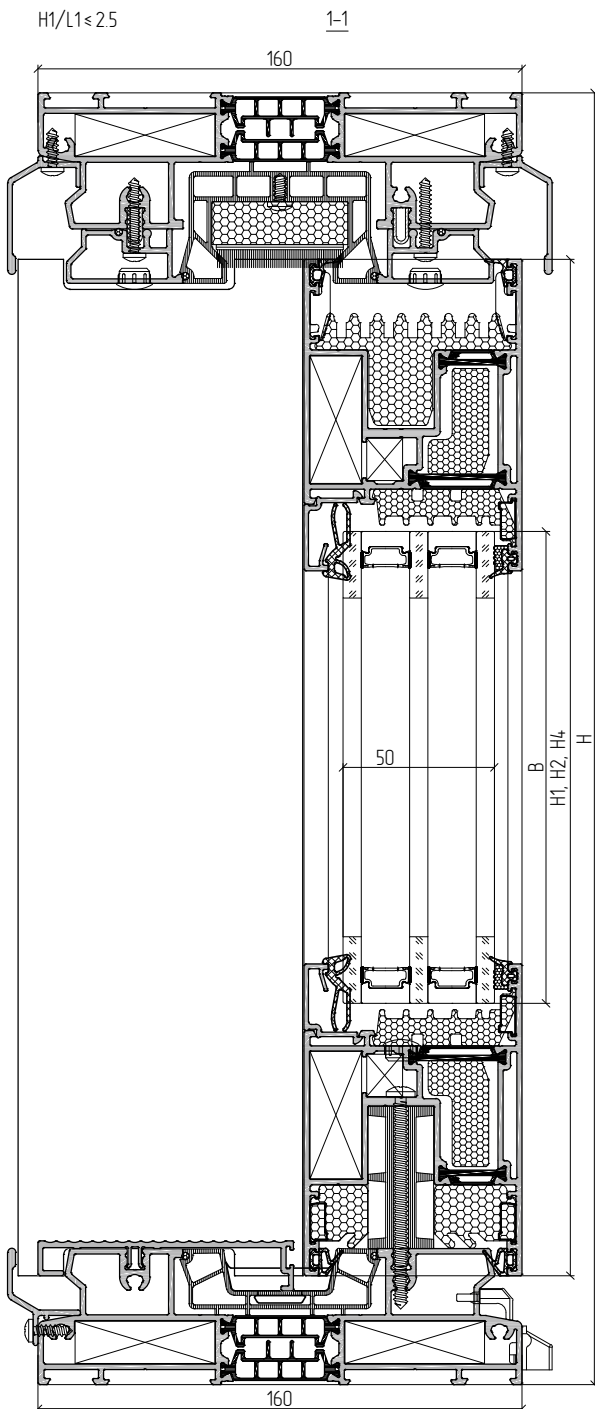
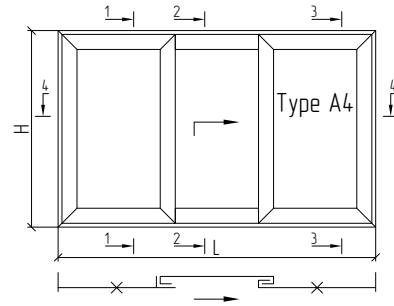

$H1/L1 \leq 25$

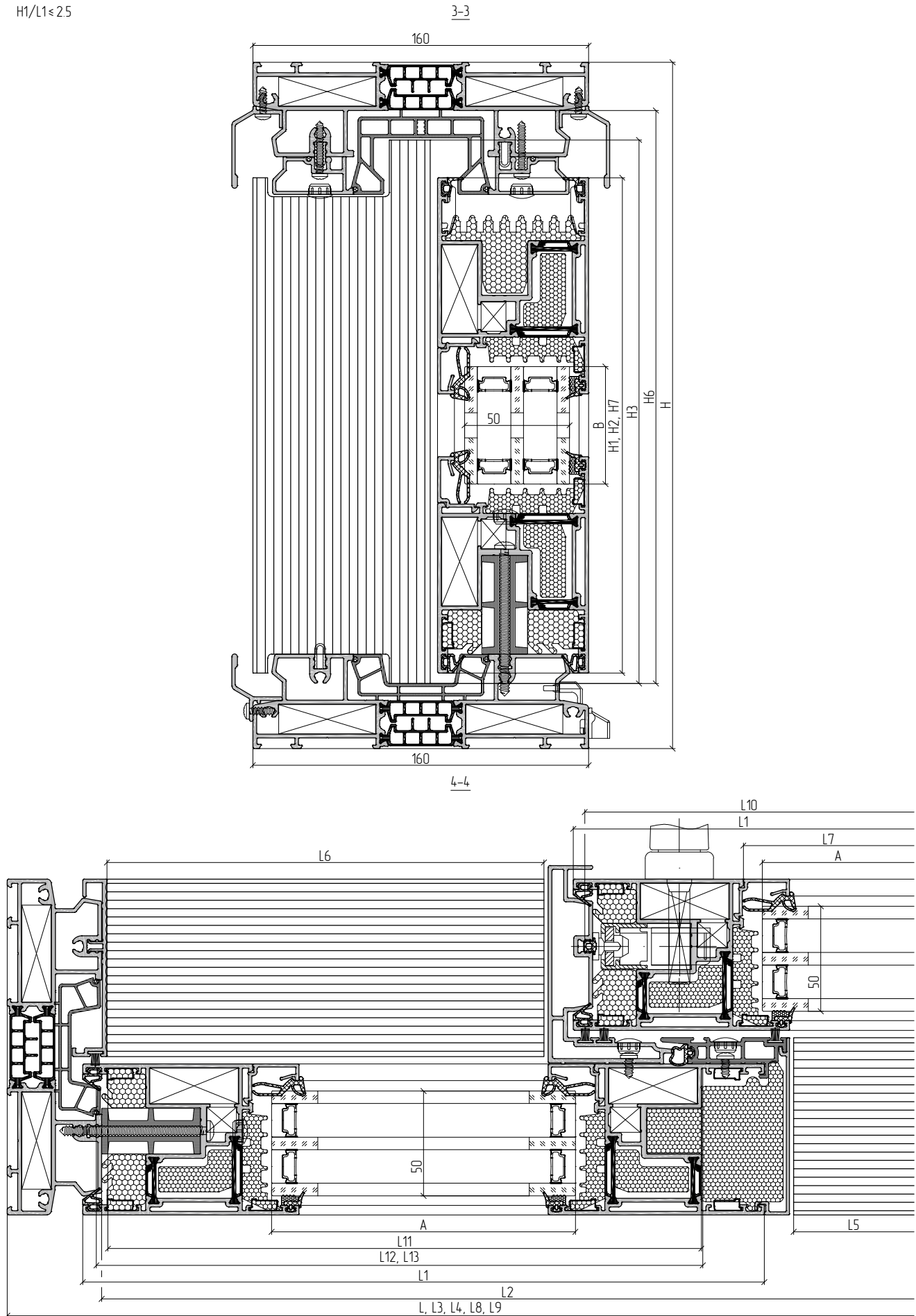

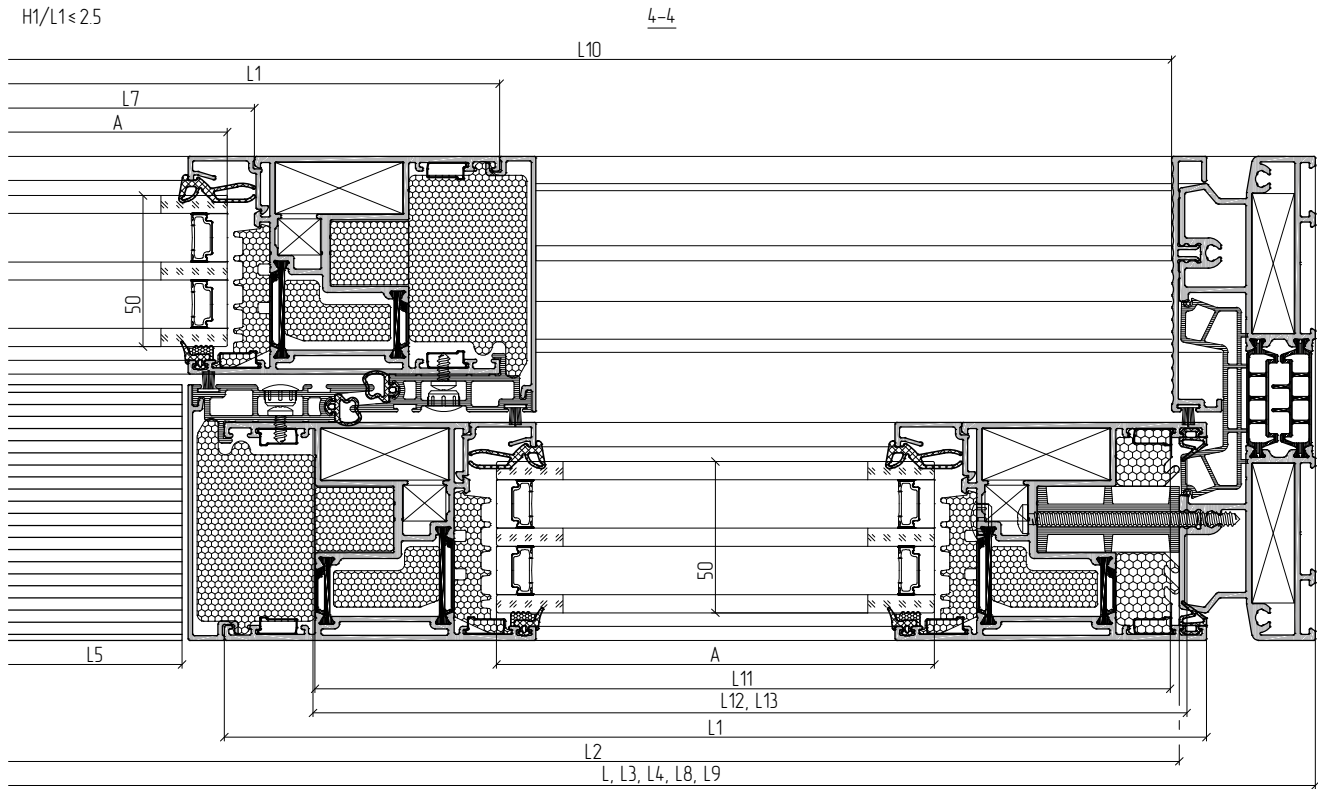

Article	Name Drawing			1..
Profile				
AYPC.SL160.0101	Frame profile Double track 		L	2
			H	2
AYPC.SL160.0202	Sash profile 		$L1=(L+110)/3$	6
			$H1=H-91$	6
AYPC.SL160.0801	Guide rail (top) 		$L2=L-90$	2
AYPC.SL160.0802	End profile 		$H2=H1$	3
AYPC.SL160.0804	Drain profile 		$L3=L$	2
AYPC.SL160.0805	Drain profile 		$L4=L$	1
AYPC.SL160.0810	Threshold profile Double/triple track Double/triple track 		$L5=L/3-173$	1
AYPC.SL160.0811	Threshold profile Double/triple track Double/triple track Double/triple track 		$L6=L/3-80$	1
			$H3=H-68$	2
AYPC.SL160.0813	Frame ledge profile 		$H4=H1$	1
AYPC.C48.0602	Glass bead profile 		$L7=L1-162$	6
			$H5=H1-206$	6
AYPC.SL160.0920	Drain profile 		* $L8=L$	1
			$H6=H-54$	2

Article	Name Drawing			1..
Profile				
AYPC.SL160.0921	Drain profile 		** $L9=L$	1
AYPC.SL160.0938	Interlock 		$H7=H1$	3
AYPC.SL160.1950	Stainless steel track 		$L10=2L/3-35$	1
			100	L/350
AYPC.SL160.0911	Foamed insert 		$L11=L1-42$	3
AYPC.SL160.0912	Foamed insert 		$H8=H1-92$	3
PE21x26	Thermal insert 		$H9=H1-92$	3
AYPC.SL160.0960	Thermal insert 		$L12=L1-36$	3
			$H10=H1-36$	3
AYPC.SL160.0961	Thermal insert 		$L13=L1-36$	3
			$H11=H1-36$	3
AYPC.W72.0911	Sealing block 		$L14=(A+B)x2-6x100$	3

Article	Name	Image	1...
Accessories			
AYPC.SL160.0940	Ledge kit		3
AYPC.SL160.0941	Sealing block		2
AYPC.SL160.0950	Corner cleat		12
AYPC.SL160.0950-01	Corner cleat		8
AYPC.SL160.0951-01	Corner cleat		12
AYPC.W50.1901	Corner cleat		36
AYPC.SL160.0905	Fixator		8
AYPC.SL160.0928	Decorative plug		L2/250+ H7/75+8
AYPC.SL160.0943	Encapsulating insert		2
AYPC.SL160.0945	Encapsulating insert		2
AYPC.SL160.0946	Encapsulating insert		4
AYPC.SL160.0949	Bearing support		18
100x56x1(3)	Leveling support		18(18)
AYPC.SL160.0929	Drain plug		L/500
AYPC.C48.0919M-01	Drain plug		2
FRK177	Rubber corner		12
FRK178	Rubber corner		6
FRK178-01	Rubber corner		6
FRK179	Rubber corner		12
Hardware			
3.9x13-A2 DIN7981	Self-tapping screw		L3/100
3.9x13-A2 DIN7982	Self-tapping screw		40
3.9x25-A2 DIN7981	Self-tapping screw		L2/250
4.2x9.5-A2 DIN7981	Self-tapping screw		H7/75
4.8x32-A2 DIN7981	Self-tapping screw		16
4.8x70-A2 DIN7981	Self-tapping screw		8
5x10 DIN6325D	Pin		24

Article	Name	Image		1...
Gaskets				
FRK50	Gasket		H7	3
FRK175	Rebate gasket		L1x2+H1x2	3
FRK176	Gasket		L1x2	3
FRK188	Gasket		H1	1
FRK193	Wedge gasket		(A+B)x2	3
FRK197	Outside gasket		(A+B)x2	3
AYPC.SL160.0948	Sealing cord		L2x2+H6x4+L8x2+L9x2	1
ISE01	Felt sealing		H3x2+H4x2+L5+L6+H7x3	1

Infill	
A=L1-180, B=H1-180	3



- When manufacturing A5 and A6 type doors with the width of 6500 mm it is necessary to install additional frame connectors and encapsulating inserts. (see page 08.52).
- Select glass bead profile and rubber gaskets according to the infill thickness (see the section 05 - Glazing table).
 - * The length of AYPC.SL160.0920 profile is given for calculation of quantity. See dimensions and cutting on page 08.09.
 - ** The length of AYPC.SL160.0921 profile is given for calculation of quantity. See dimensions and cutting on page 08.28.

Example of lift and slide door calculations. Types A7, A8

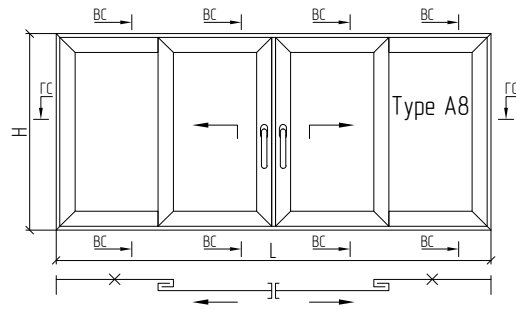
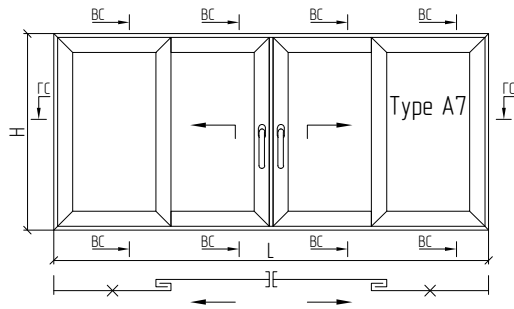

$H1/L1 \leq 25$

Vertical sections

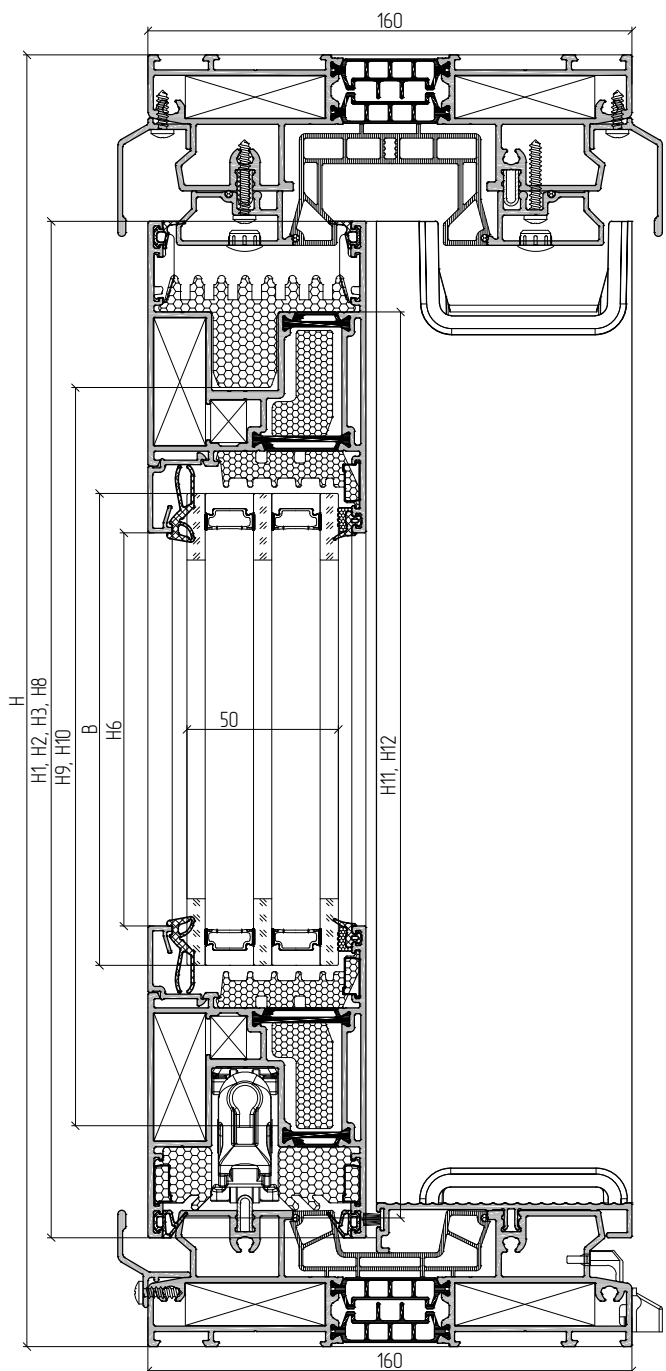
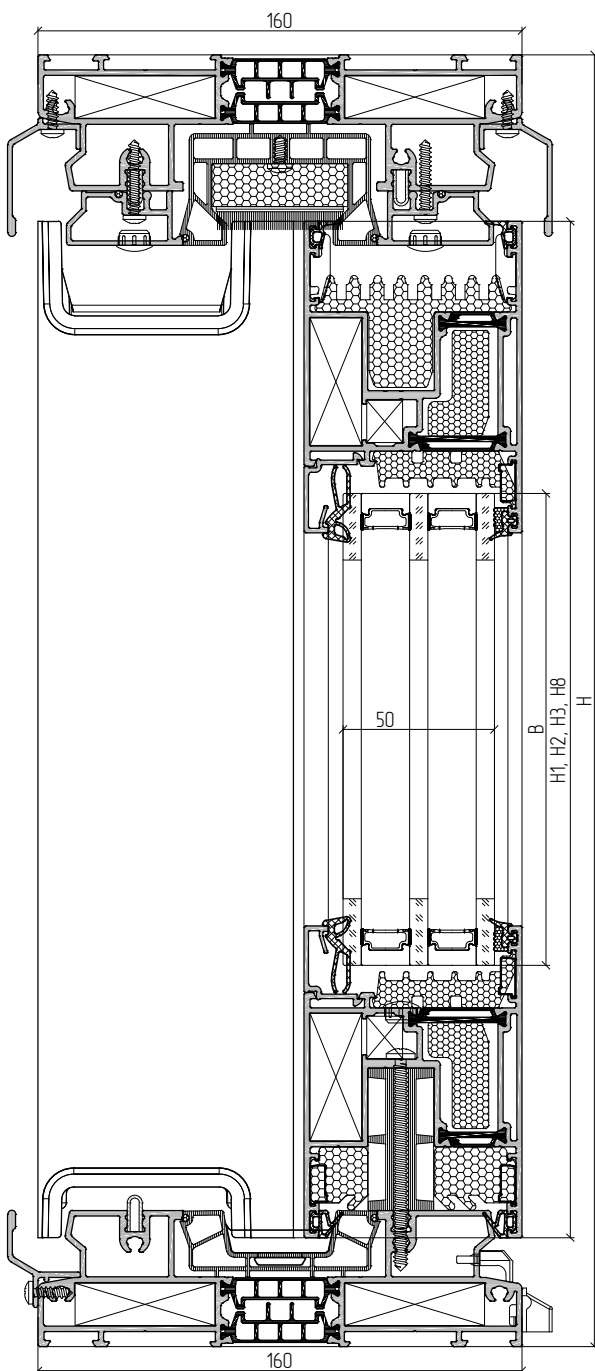

$H1/L1 \leq 25$

Vertical sections

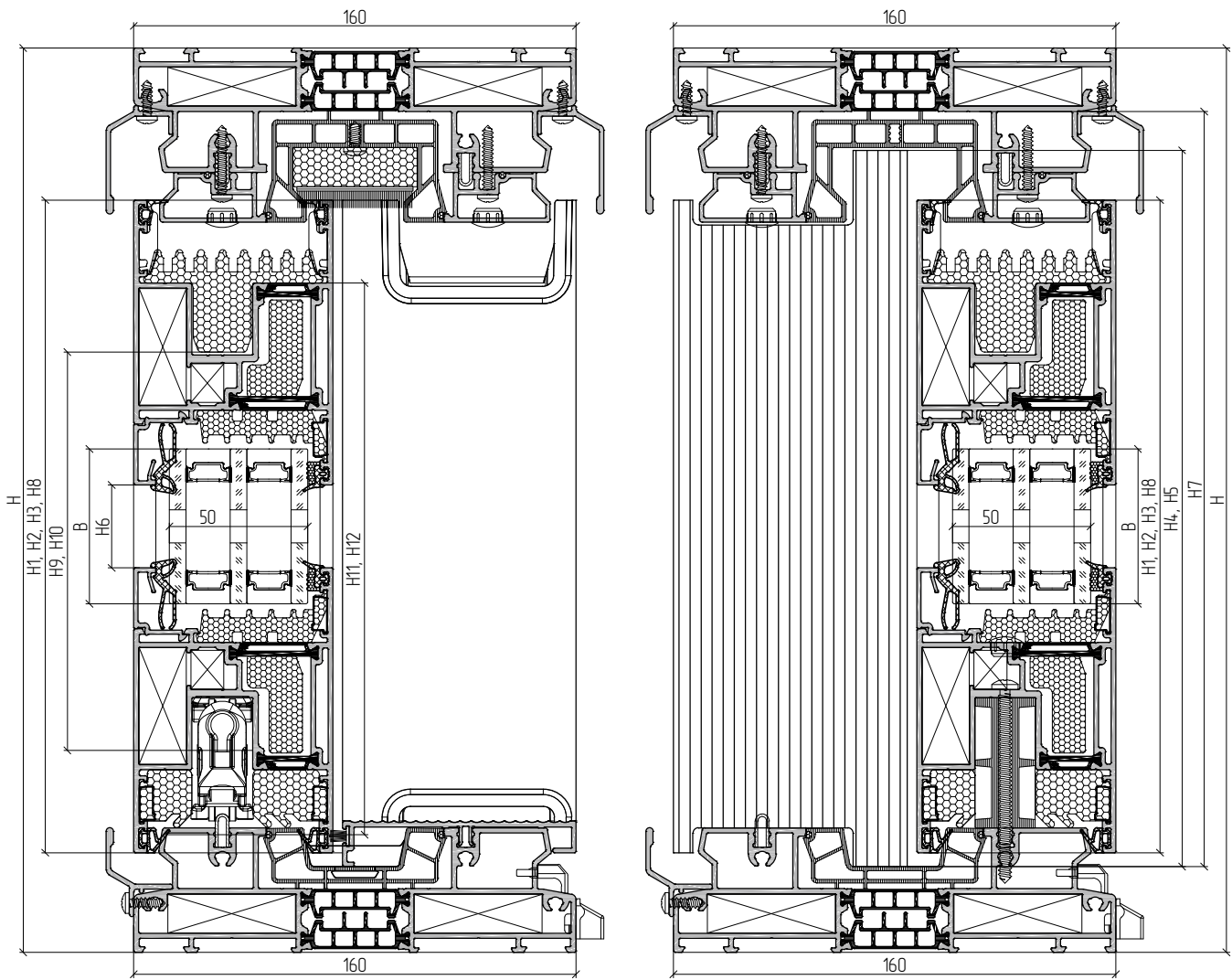



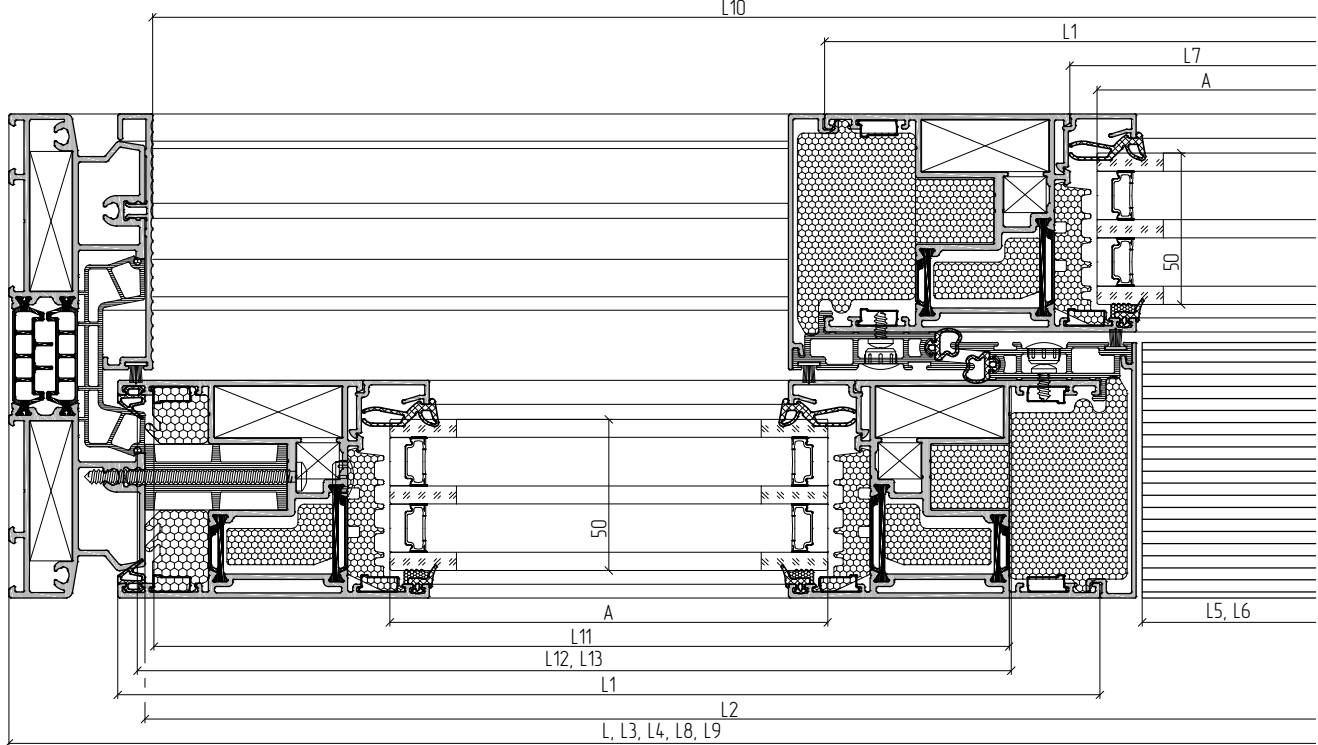





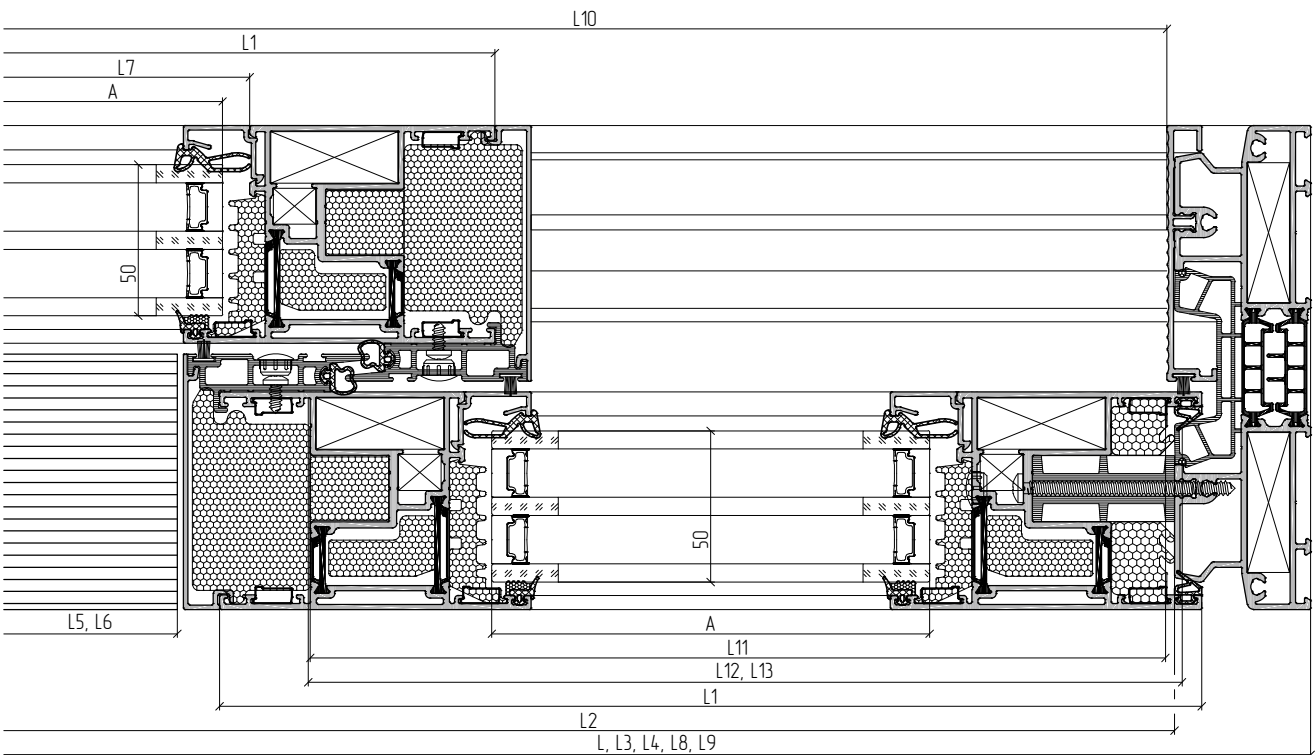
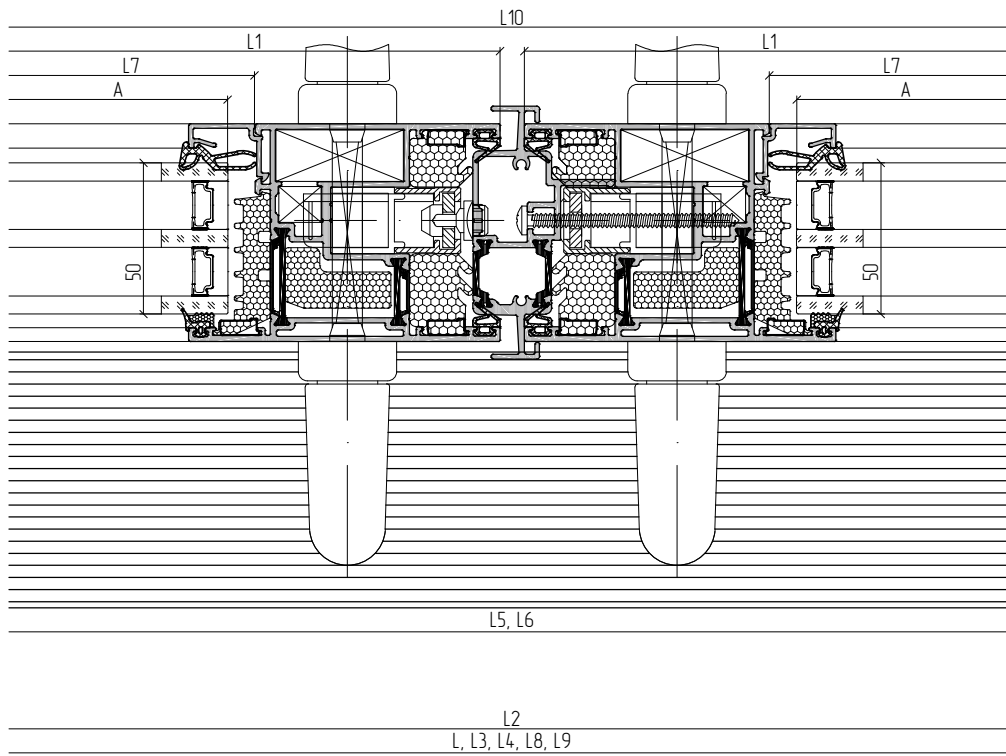

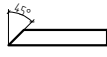
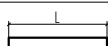
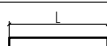
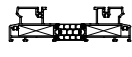
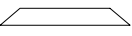

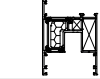
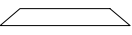

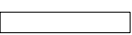
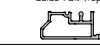

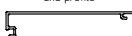
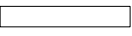



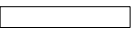

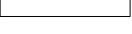
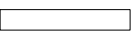
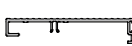
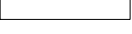
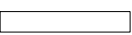
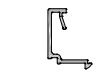
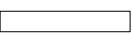
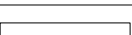

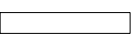
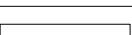

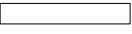

Horizontal sections

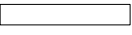

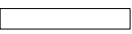
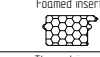
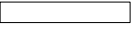
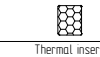
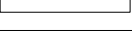

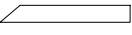

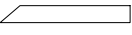

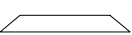

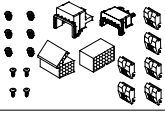
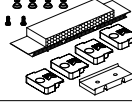

















H1/L1 ≤ 25









Horizontal sections

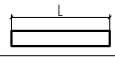
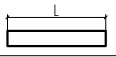

Article	Name Image		Type A7		Type A8	
				1..		1..
AYPC.SL160.0101	Frame profile: Double track 		L	2	L	2
			H	2	H	2
AYPC.SL160.0202	Sash profile 		$L1=(L+102)/4$	8	$L1=(L+102)/4$	8
			$H1=H-91$	8	$H1=H-91$	8
AYPC.SL160.0504	Interlocking profile 		$H2=H1$	1	$H2=H1$	1
AYPC.SL160.0801	Guide rail (top) 		$L2=L-90$	2	$L2=L-90$	2
AYPC.SL160.0802	End profile 		$H3=H1$	4	$H3=H1$	4
AYPC.SL160.0804	Drain profile 		$L3=L$	2	$L3=L$	2
AYPC.SL160.0805	Drain profile 		$L4=L$	1	$L4=L$	1
AYPC.SL160.0810	Threshold profile: Double/triple track 		$L5=L/2-151$	1	-	-
			-	-	$H4=H-68$	2
AYPC.SL160.0811	Threshold profile: Double/triple track 		-	-	$L6=L/2-151$	1
			$H5=H-68$	2	-	-
AYPC.C4.8.0602	Glass bead profile 		$L7=L1-162$	8	$L7=L1-162$	8
			$H6=H1-206$	8	$H6=H1-206$	8
AYPC.SL160.0920	Drain profile 		* $L8=L$	1	* $L8=L$	1
			$H7=H-54$	2	$H7=H-54$	2
AYPC.SL160.0921	Drain profile 		** $L9=L$	1	** $L9=L$	1
AYPC.SL160.0938	Interlock 		$H8=H1$	4	$H8=H1$	4
AYPC.SL160.1950	Stainless steel track 		$L10=L-95$	1	$L10=L-95$	1
			100	L/350	100	L/350
AYPC.SL160.0911	Foamed insert 		$L11=L1-42$	4	$L11=L1-42$	4
AYPC.SL160.0912	Foamed insert 		$H9=H1-92$	4	$H9=H1-92$	4
PE21x26	Thermal insert 		$H10=H1-92$	4	$H10=H1-92$	4
AYPC.SL160.0960	Thermal insert 		$L12=L1-36$	4	$L12=L1-36$	4
			$H11=H1-36$	4	$H11=H1-36$	4
AYPC.SL160.0961	Thermal insert 		$L13=L1-36$	4	$L13=L1-36$	4
			$H12=H1-36$	4	$H12=H1-36$	4
AYPC.W72.0911	Rebate insulation 		$L14=(A+B)x2-6x100$	4	$L14=(A+B)x2-6x100$	4

Article	Name	1...	
		Type A7	Type A8
Accessories			
AYPC.SL160.0940	Ledge kit 	4	4
AYPC.SL160.0941	Sealing block 	2	2
AYPC.SL160.0950	Corner cleat 	16	16
AYPC.SL160.0950-01	Corner cleat 	8	8
AYPC.SL160.0951-01	Corner cleat 	16	16
AYPC.W50.1901	Corner cleat 	48	48
AYPC.SL160.0905	Fixator 	8	8
AYPC.SL160.0928	Decorative plug 	L2/250+ H2/450+ H8/75+8	L2/250+ H2/450+ H8/75+8
AYPC.SL160.0933	Interlock plug 	2	2
AYPC.SL160.0943	Encapsulating insert 	2	2
AYPC.SL160.0945	Encapsulating insert 	2	2
AYPC.SL160.0946	Encapsulating insert 	4	4
AYPC.SL160.0949	Bearing support 	24	24

Article	Name	1...	
		Type A7	Type A8
Accessories			
100x56x1(3)	Leveling support 	24(24)	24(24)
AYPC.SL160.0929	Water drain plug 	L/500	L/500
AYPC.C48.0919M-01	Water drain plug 	2	2
FRK177	Rubber corner 	16	16
FRK178	Rubber corner 	8	8
FRK178-01	Rubber corner 	8	8
FRK179	Rubber corner 	16	16
Hardware			
3.9x13-A2 DIN7981	Self-tapping screw 	L3/100	L3/100
3.9x13-A2 DIN7982	Self-tapping screw 	52	52
3.9x25-A2 DIN7981	Self-tapping screw 	L2/250	L2/250
4.2x9.5-A2 DIN7981	Self-tapping screw 	H8/75	H8/75
4.8x32-A2 DIN7981	Self-tapping screw 	16	16
4.8x70-A2 DIN7981	Self-tapping screw 	H2/450+8	H2/450+8
5x10 DIN6325D	Pin 	32	32

Article	Name	Type A7		Type A8	
			1...		1...
Gaskets					
FRK50	Gasket 	H7	4	H7	4
FRK175	Rebate gasket 	L1x2+H1x2	4	L1x2+H1x2	4
FRK176	Gasket 	L1x2	4	L1x2	4
FRK193	Wedge gasket 	(A+B)x2	4	(A+B)x2	4
FRK197	Outside gasket 	(A+B)x2	4	(A+B)x2	4
AYPC.SL160.0948	Sealing cord 	L2x2+H7x4+L8x2+L9x2	1	L2x2+H7x4+L8x2+L9x2	1
ISE01	Felt sealing 	L5+H5x2+H8x4	1	H4x2+L6+H8x4	1

Infill			
Type A7		Type A8	
A=L1-180, B=H1-180	4	A=L1-180, B=H1-180	4







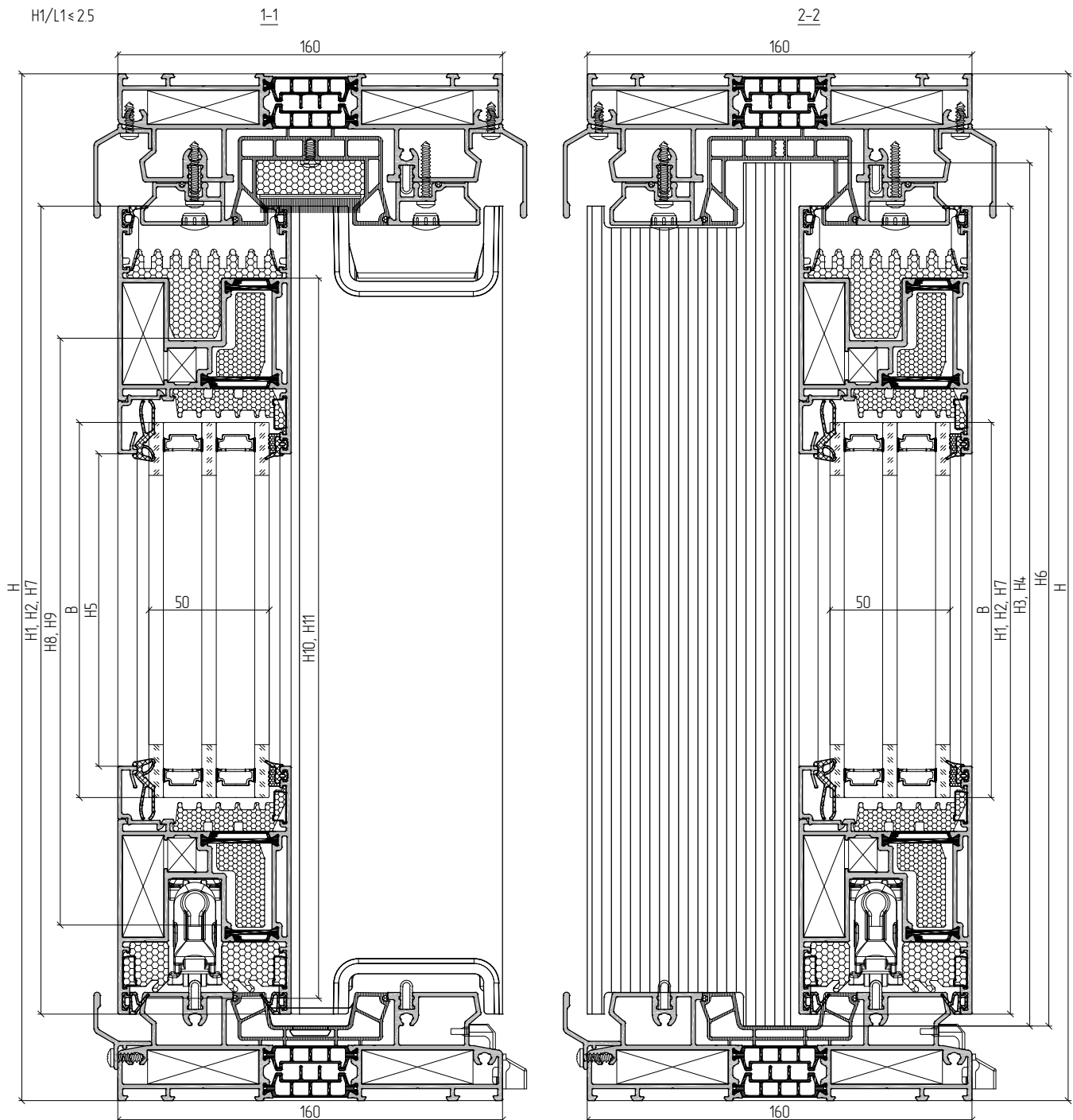
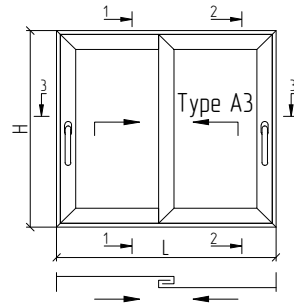

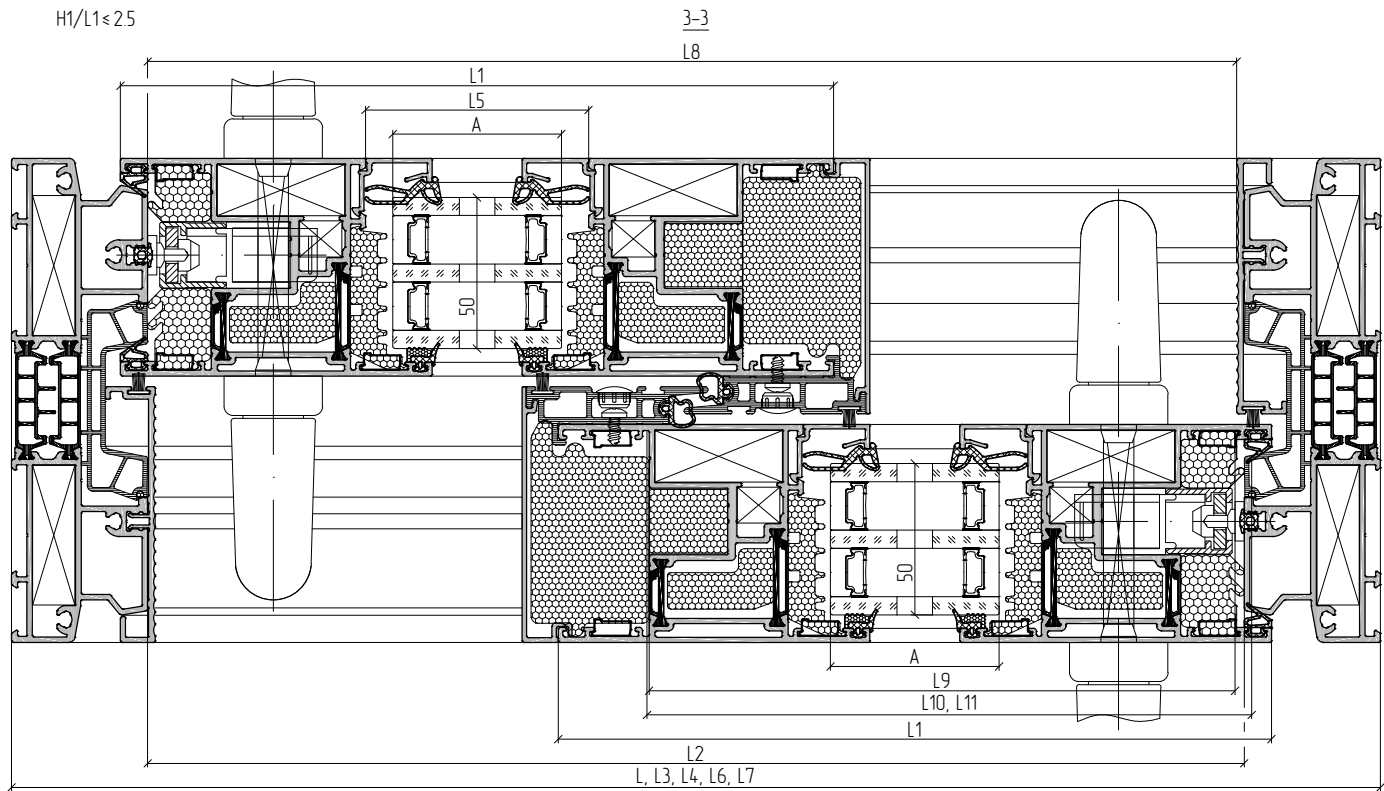

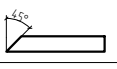
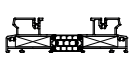
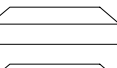
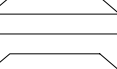

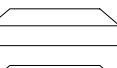
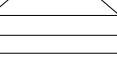

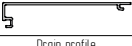
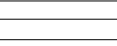

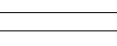

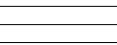
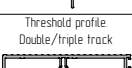
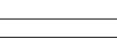
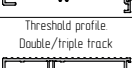
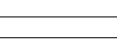

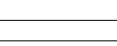

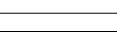
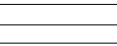

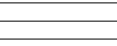
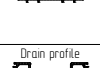
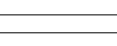

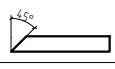
- When manufacturing A5 and A6 type doors with the width of 6500 mm it is necessary to install additional frame connectors and encapsulating inserts. (see page 08.52).
 - Select glass bead profile and rubber gaskets according to the infill thickness (see the section 05 – Glazing table).
- * The length of AYPC.SL160.0920 profile is given for calculation of quantity. See dimensions and cutting on page 08.09.
 ** The length of AYPC.SL160.0921 profile is given for calculation of quantity. See dimensions and cutting on page 08.28.

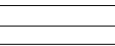
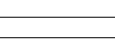
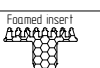
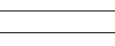
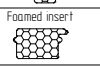
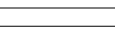
Example of lift and slide door calculations. Type A3

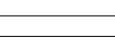

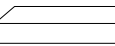
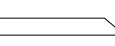

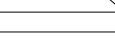
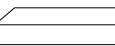
Article	Name	Image		L	1..
Profile					
AYPC.SL160.0101	Frame profile: Double track			L	2
				H	2
AYPC.SL160.0202	Sash profile			$L1=L/2+9.5$	4
				$H1=H-91$	4
AYPC.SL160.0801	Guide rail (top)			$L2=L-90$	2
AYPC.SL160.0802	End profile			$H2=H1$	2
AYPC.SL160.0804	Drain profile			$L3=L$	2
AYPC.SL160.0805	Drain profile			$L4=L$	1
AYPC.SL160.0810	Threshold profile: Double/triple track			$H3=H-68$	1
AYPC.SL160.0811	Threshold profile: Double/triple track			$H4=H-68$	1
AYPC.C48.0602	Glass bead profile			$L5=L-162$	4
				$H5=H1-206$	4
AYPC.SL160.0920	Drain profile			* $L6=L$	1
				$H6=H-54$	2
AYPC.SL160.0921	Drain profile			** $L7=L$	1
AYPC.SL160.0938	Interlock			$H7=H1$	2

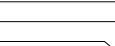
Article	Name	Image		L	1..
Profile					
AYPC.SL160.1950	Stainless steel track			$L8=L-93$	2
				100	$L/350$
AYPC.SL160.0911	Foamed insert			$L9=L-42$	2
AYPC.SL160.0912	Foamed insert			$H8=H1-92$	2
PE21x26	Thermal insert			$H9=H1-92$	2
AYPC.SL160.0960	Thermal insert			$L10=L-36$	2
				$H10=H1-36$	2
AYPC.SL160.0961	Thermal insert			$L11=L-36$	2
				$H11=H1-36$	2
AYPC.W72.0911	Rebate insulation			$L12=(A+B)x2-6x100$	2

Article	Name	Image	1...
Accessories			
AYPC.SL160.0940	Ledge kit		2
AYPC.SL160.0941	Sealing block		1
AYPC.SL160.0950	Corner cleat		8
AYPC.SL160.0950-01	Corner cleat		8
AYPC.SL160.0951-01	Corner cleat		8
AYPC.W50.1901	Corner cleat		24
AYPC.SL160.0928	Decorative plug		L2/250+ H7/150
AYPC.SL160.0943	Encapsulating insert		2
AYPC.SL160.0945	Encapsulating insert		2
AYPC.SL160.0946	Encapsulating insert		4
AYPC.SL160.0949	Bearing support		12
100x56x1(3)	Leveling support		12(12)
AYPC.SL160.0929	Water drain plug		L/500
AYPC.C48.0919M-01	Water drain plug		L/500
FRK177	Rubber corner		8
FRK178	Rubber corner		4
FRK178-01	Rubber corner		4
FRK179	Rubber corner		8
Hardware			
3.9x13-A2 DIN7981	Self-tapping screw		L3/100
3.9x13-A2 DIN7982	Self-tapping screw		32
3.9x25-A2 DIN7981	Self-tapping screw		L2/250
4.2x9.5-A2 DIN7981	Self-tapping screw		H7/150
5x10 DIN6325D	Pin		16

Article	Name	Image		1...
Gaskets				
FRK50	Gasket		H7	2
FRK175	Rebate gasket		L1x2+H1x2	2
FRK176	Gasket		L1x2	2
FRK188	Gasket		H1	2
FRK193	Wedge gasket		(A+B)x2	2
FRK197	Outside gasket		(A+B)x2	2
AYPC.SL160.0948	Sealing cord		L2x2+L6x2+H6x4+L7x2	1
ISE01	Felt sealing		H3+H4+H7x2	1

Infill	
A=L1-180, B=H1-180	2



- When manufacturing A5 and A6 type doors with the width of 6500 mm it is necessary to install additional frame connectors and encapsulating inserts. (see page 08.52).
- Select glass bead profile and rubber gaskets according to the infill thickness (see the section 05 - Glazing table).
 - * The length of AYPC.SL160.0920 profile is given for calculation of quantity. See dimensions and cutting on page 08.09.
 - ** The length of AYPC.SL160.0921 profile is given for calculation of quantity. See dimensions and cutting on page 08.28.

Example of lift and slide door calculations. Types A9, A10

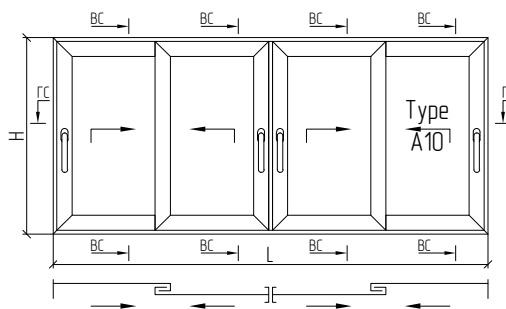
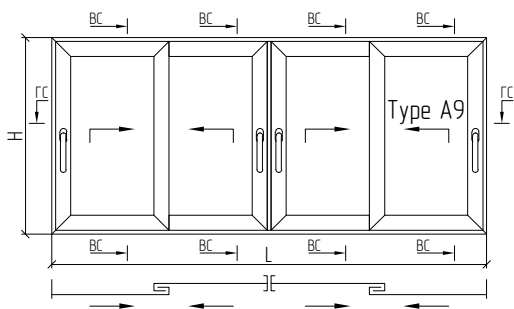

$H1/L1 \leq 25$

Vertical sections

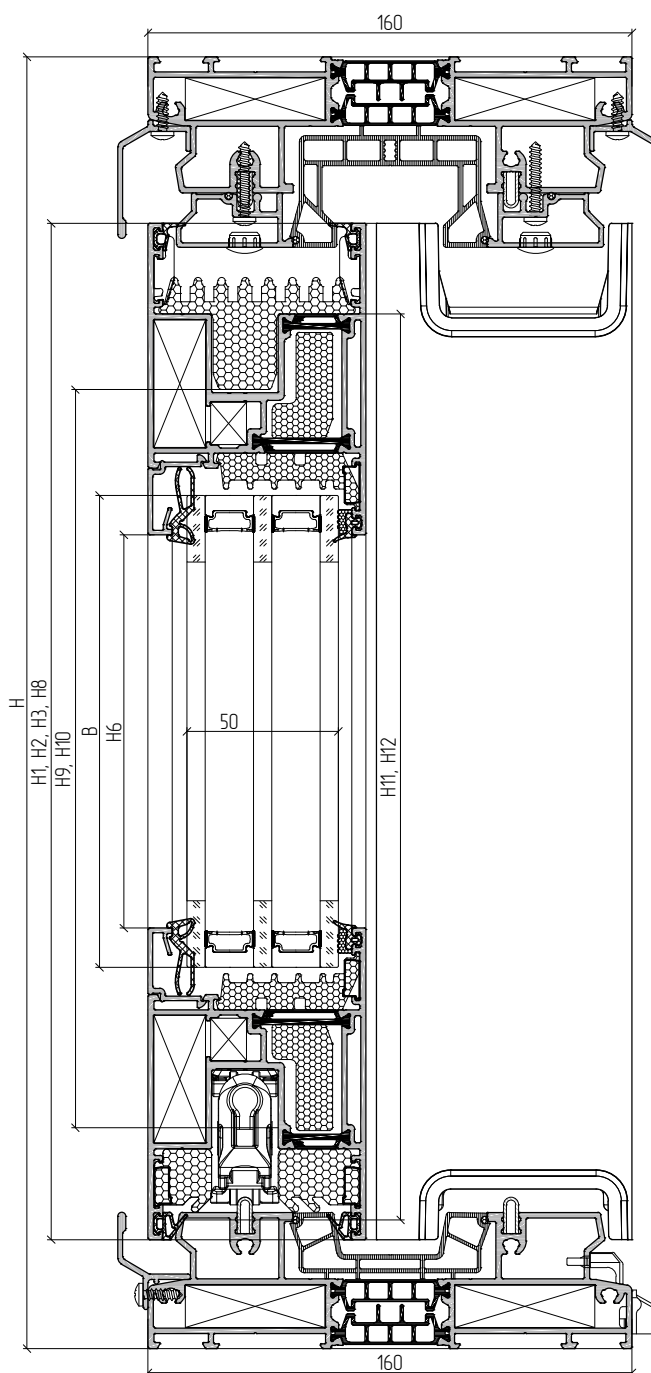
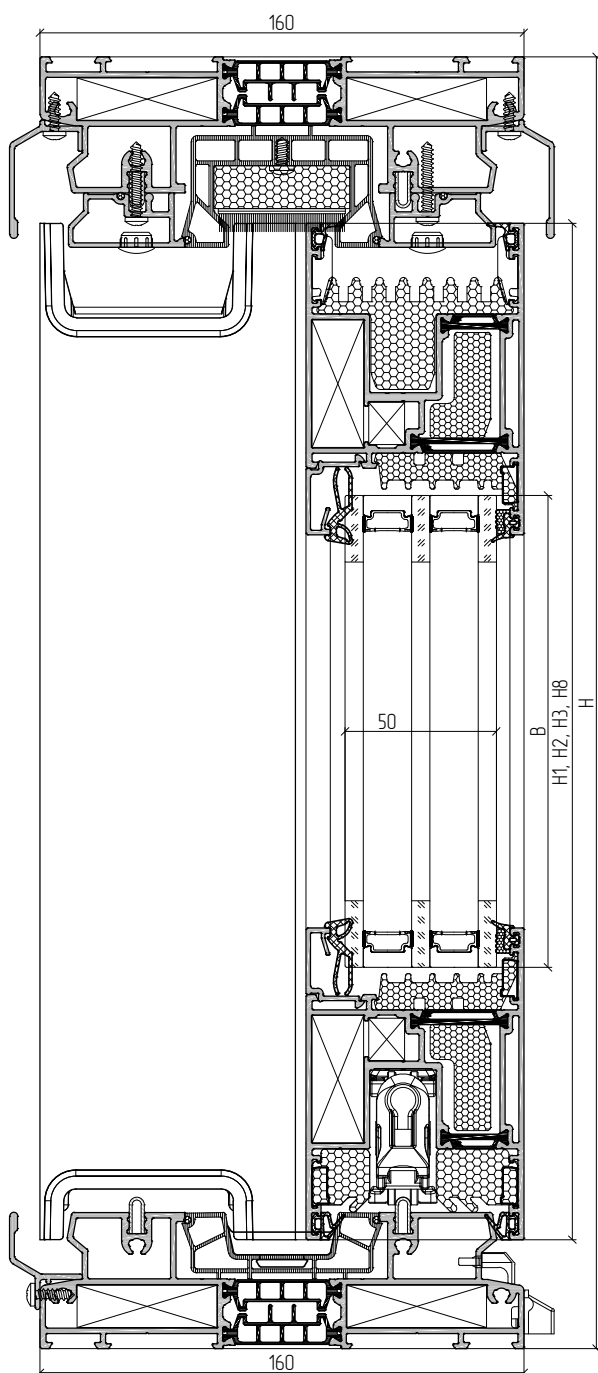

$H1/L1 \leq 25$

Vertical sections

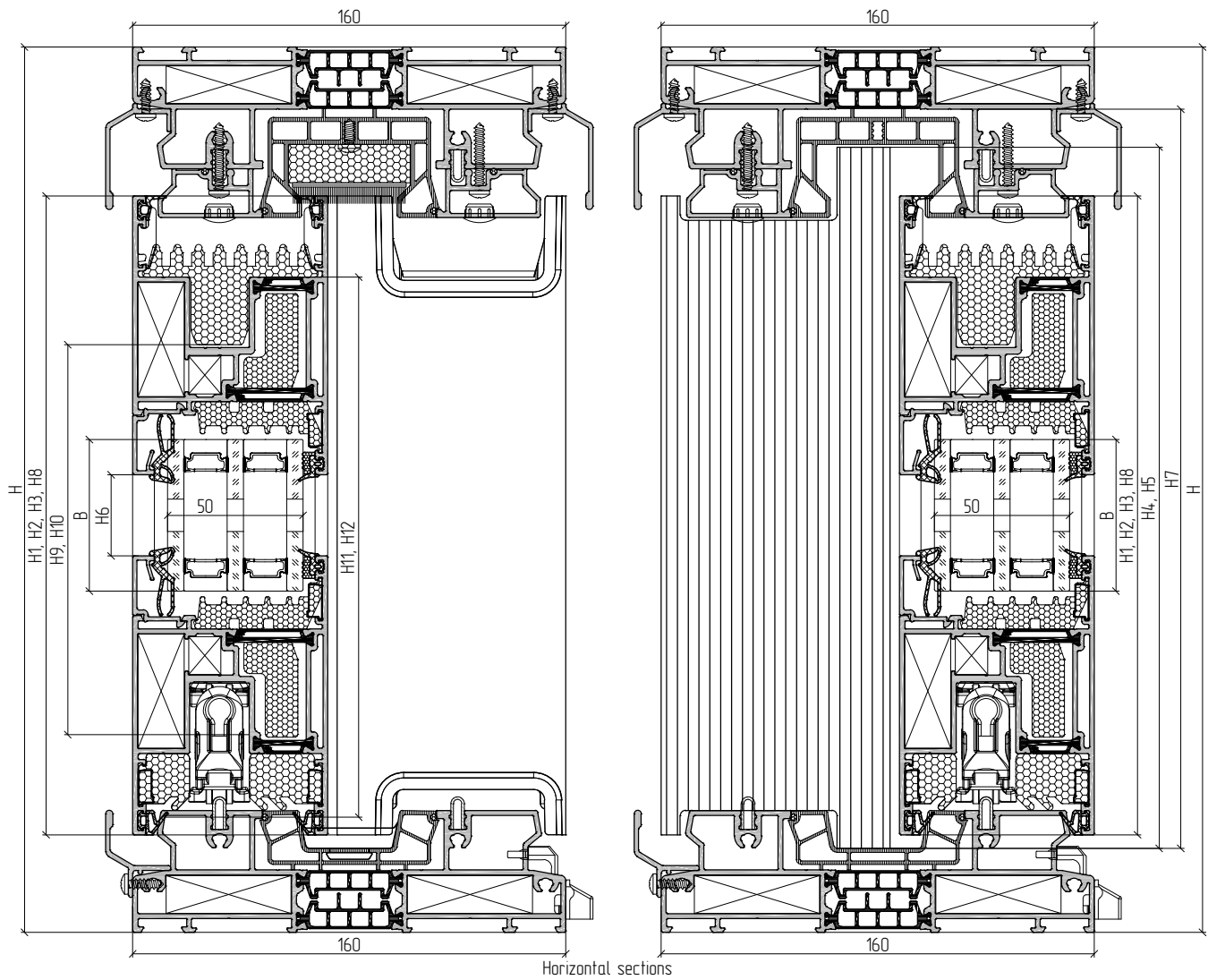



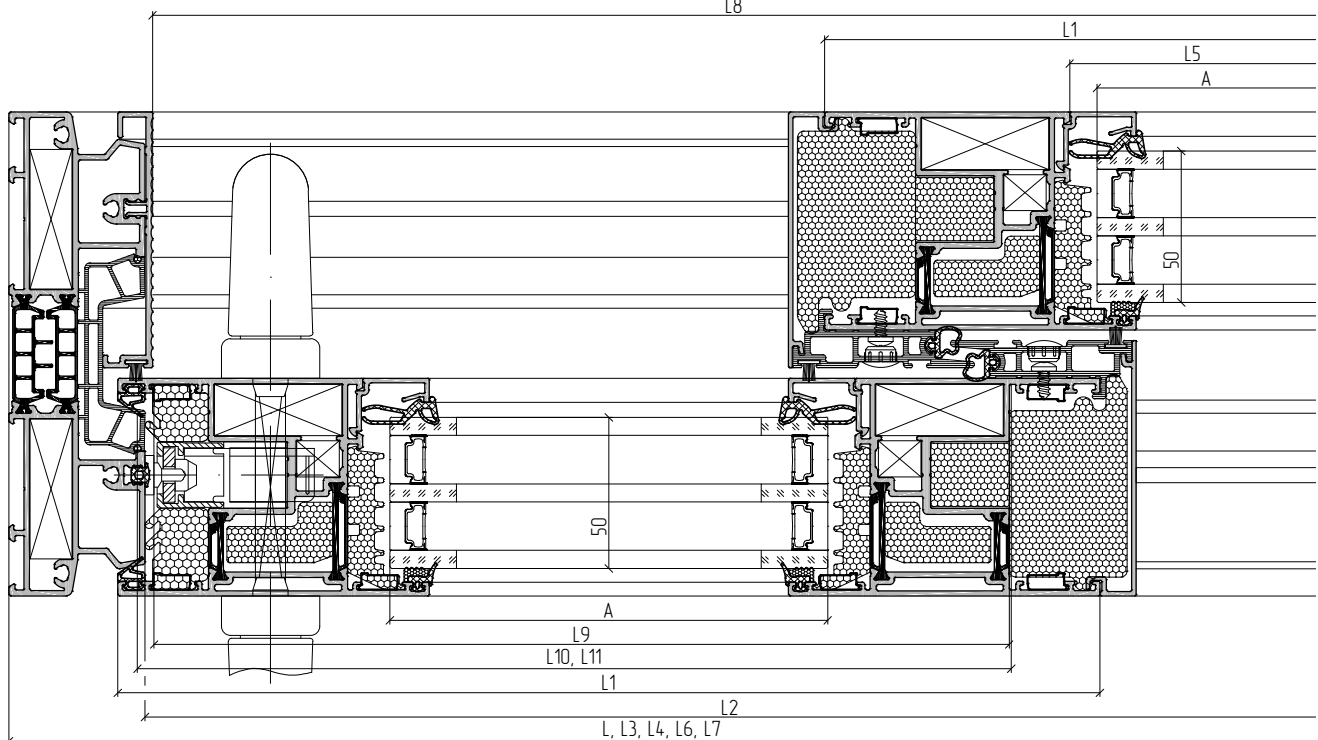





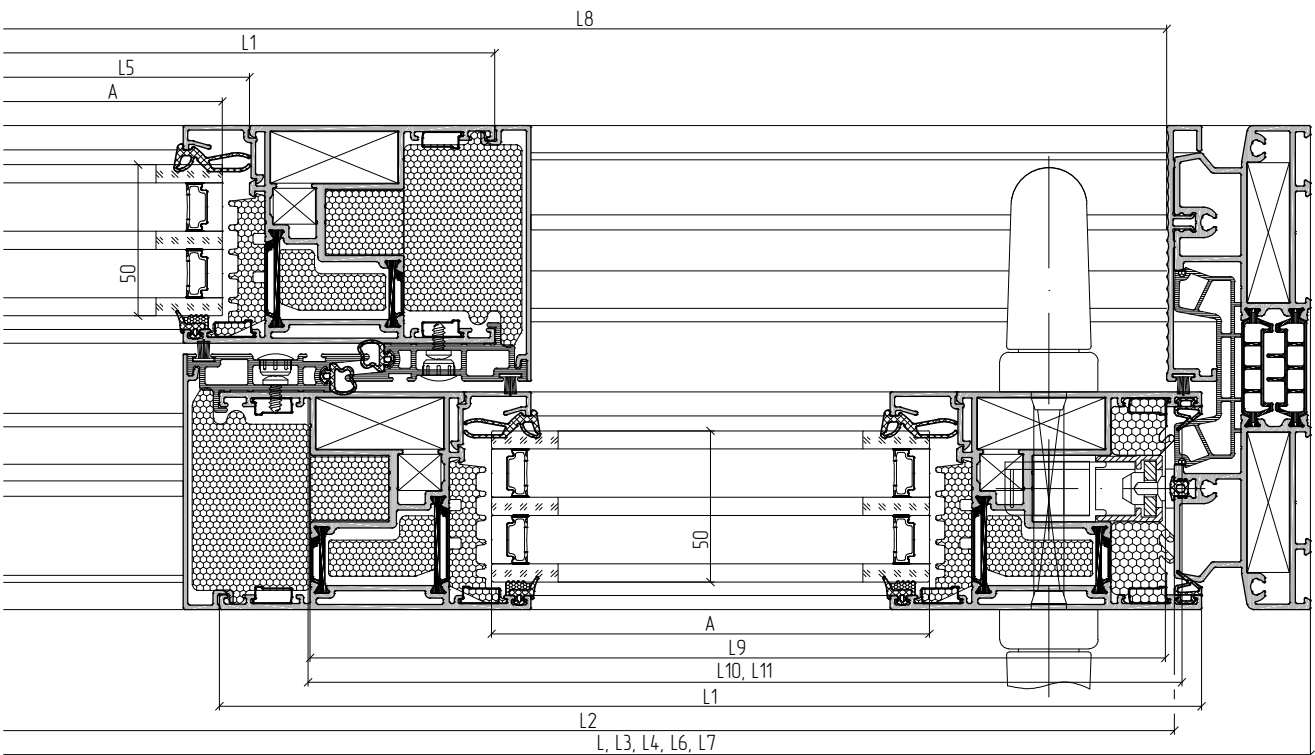
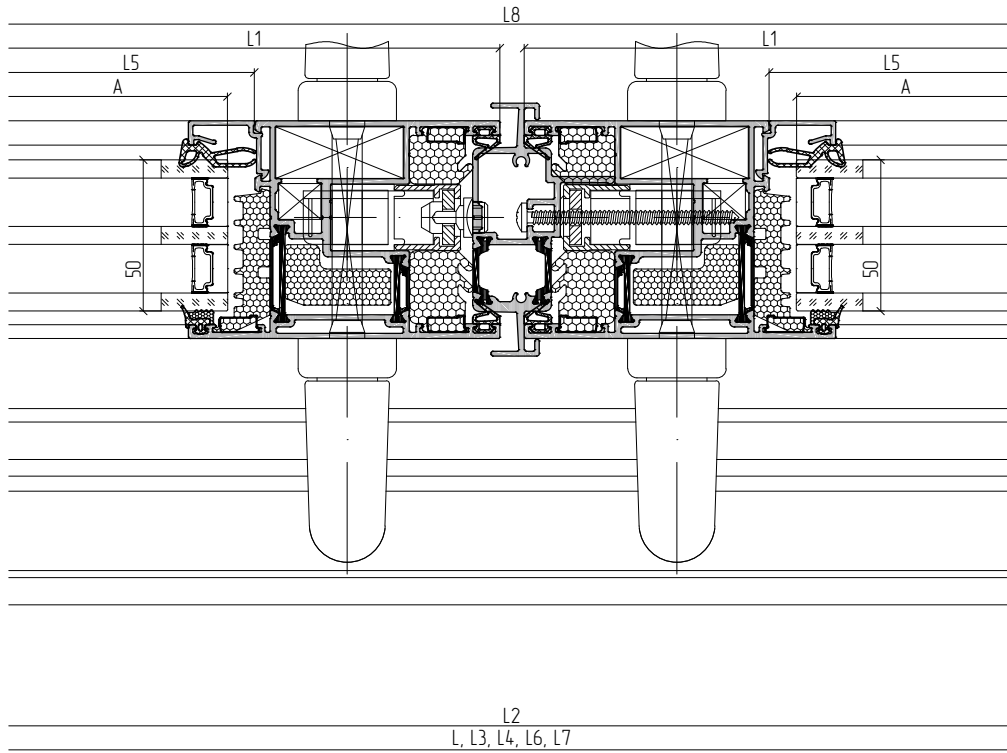

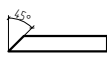
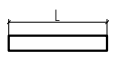
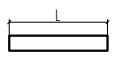
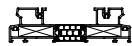
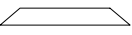

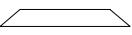
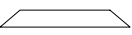

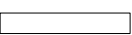

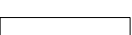





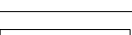
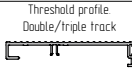
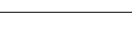
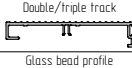
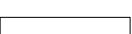

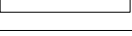
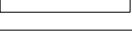

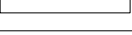
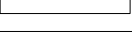





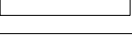



L8

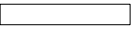

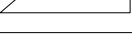
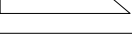







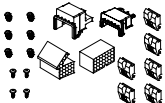
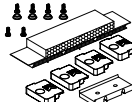















H1/L1 ≤ 25









Horizontal sections

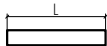
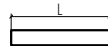

Article	Name Image		Type A9		Type A10	
				1..		1..
Profile						
AYPC.SL160.0101	Frame profile Double track 		L	2	L	2
			H	2	H	2
AYPC.SL160.0202	Sash profile 		$L1=(L+102)/4$	8	$L1=(L+102)/4$	8
			$H1=H-91$	8	$H1=H-91$	8
AYPC.SL160.0504	Interlocking profile 		$H2=H1$	1	$H2=H1$	1
AYPC.SL160.0801	Guide rail (top) 		$L2=L-90$	2	$L2=L-90$	2
AYPC.SL160.0802	End profile 		$H3=H1$	4	$H3=H1$	4
AYPC.SL160.0804	Drain profile 		$L3=L$	2	$L3=L$	2
AYPC.SL160.0805	Drain profile 		$L4=L$	1	$L4=L$	1
AYPC.SL160.0811	Threshold profile Double/triple track 		$H4=H-68$	2	-	-
AYPC.SL160.0810	Threshold profile Double/triple track 		-	-	$H5=H-68$	2
AYPC.C48.0602	Glass bead profile 		$L5=L1-162$	8	$L5=L1-162$	8
			$H6=H1-206$	8	$H6=H1-206$	8
AYPC.SL160.0920	Drain profile 		* $L6=L$	1	* $L6=L$	1
			$H7=H-54$	2	$H7=H-54$	2
AYPC.SL160.0921	Drain profile 		** $L7=L$	1	** $L7=L$	1
AYPC.SL160.0938	Interlock 		$H8=H1$	4	$H8=H1$	4
AYPC.SL160.1950	Stainless steel track 		$L8=L-95$	2	$L8=L-95$	2
			100	L/350	100	L/350
AYPC.SL160.0911	Foamed insert 		$L9=L1-42$	4	$L9=L1-42$	4
AYPC.SL160.0912	Foamed insert 		$H9=H1-92$	4	$H9=H1-92$	4
PE21x26	Thermal insert 		$H10=H1-92$	4	$H10=H1-92$	4
AYPC.SL160.0960	Thermal insert 		$L10=L1-36$	4	$L10=L1-36$	4
			$H11=H1-36$	4	$H11=H1-36$	4
AYPC.SL160.0961	Thermal insert 		$L11=L1-36$	4	$L11=L1-36$	4
			$H12=H1-36$	4	$H12=H1-36$	4
AYPC.W72.0911	Rebate insulation 		$L12=(A+B)x2-6x100$	4	$L12=(A+B)x2-6x100$	4

Article	Name	1...	
		Type A9	Type A10
Accessories			
AYPC.SL160.0940	Ledge kit 	4	4
AYPC.SL160.0941	Sealing block 	2	2
AYPC.SL160.0950	Corner cleat 	16	16
AYPC.SL160.0950-01	Corner cleat 	8	8
AYPC.SL160.0951-01	Corner cleat 	16	16
AYPC.W50.1901	Corner cleat 	48	48
AYPC.SL160.0928	Decorative plug 	L2/250+ H2/450+ H8/75	L2/250+ H2/450+ H8/75
AYPC.SL160.0933	Interlock plug 	2	2
AYPC.SL160.0943	Encapsulating insert 	2	2
AYPC.SL160.0945	Encapsulating insert 	2	2
AYPC.SL160.0946	Encapsulating insert 	4	4
AYPC.SL160.0949	Bearing support 	24	24

Article	Name	1...	
		Type A9	Type A10
Accessories			
100x56x1(3)	Leveling support 	24(24)	24(24)
AYPC.SL160.0929	Water drain plug 	L/500	L/500
AYPC.C48.0919M-01	Water drain plug 	L/500	L/500
FRK177	Rubber corner 	16	16
FRK178	Rubber corner 	8	8
FRK178-01	Rubber corner 	8	8
FRK179	Rubber corner 	16	16
Hardware			
3.9x13-A2 DIN7981	Self-tapping screw 	L3/100	L3/100
3.9x13-A2 DIN7982	Self-tapping screw 	52	52
3.9x25-A2 DIN7981	Self-tapping screw 	L2/250	L2/250
4.2x9.5-A2 DIN7981	Self-tapping screw 	H8/75	H8/75
4.8x70-A2 DIN7981	Self-tapping screw 	H2/450	H2/450
5x10 DIN6325D	Pin 	32	32

Article	Name	Image	Type A9		Type A10	
				1...		1...
Gaskets						
FRK50	Gasket 	H8	4	H8	4	
FRK175	Rebate gasket 	L1x2+H1x2	4	L1x2+H1x2	4	
FRK176	Gasket 	L1x2	4	L1x2	4	
FRK188	Gasket 	H1	2	H1	2	
FRK193	Wedge gasket 	(A+B)x2	4	(A+B)x2	4	
FRK197	Outside gasket 	(A+B)x2	4	(A+B)x2	4	
AYPC.SL160.0948	Sealing cord 	L2x2+L6x2+H7x4+L7x2	1	L2x2+L6x2+H7x4+L7x2	1	
ISE01	Felt sealing 	H4x2+H8x4	1	H5x2+H8x4	1	

Infill			
Type A9		Type A10	
A=L1-180, B=H1-180	4	A=L1-180, B=H1-180	4



- When manufacturing A5 and A6 type doors with the width of 6500 mm it is necessary to install additional frame connectors and encapsulating inserts. (see page 08.52).
 - Select glass bead profile and rubber gaskets according to the infill thickness (see the section 05 - Glazing table).
- * The length of AYPC.SL160.0920 profile is given for calculation of quantity. See dimensions and cutting on page 08.09.
 ** The length of AYPC.SL160.0921 profile is given for calculation of quantity. See dimensions and cutting on page 08.28.

Example of lift and slide door calculations. Types B1, B2

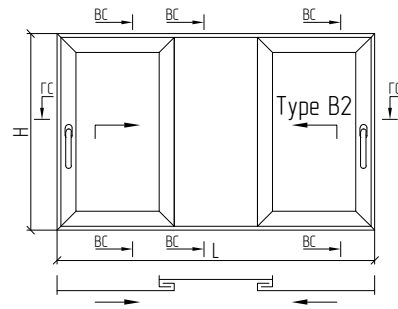
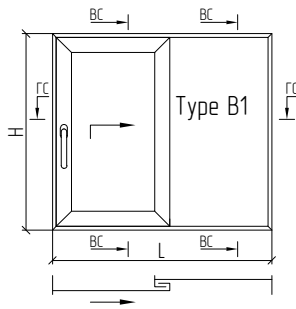





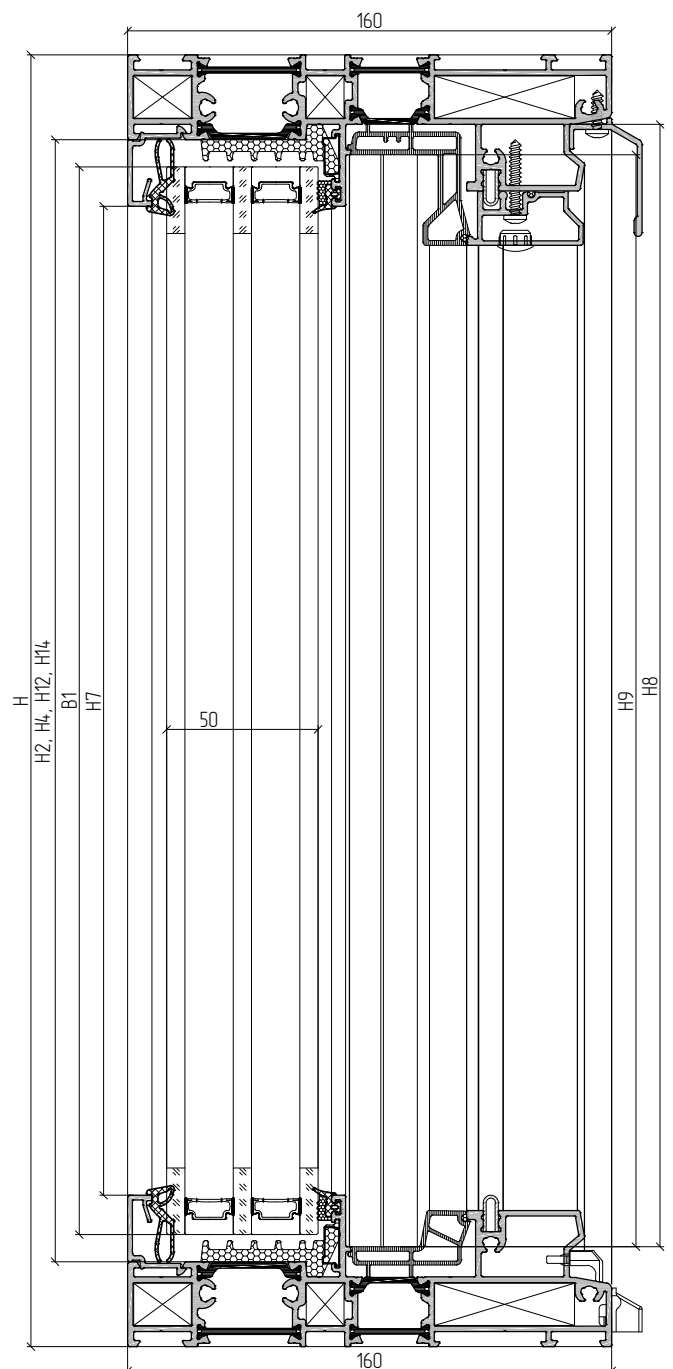
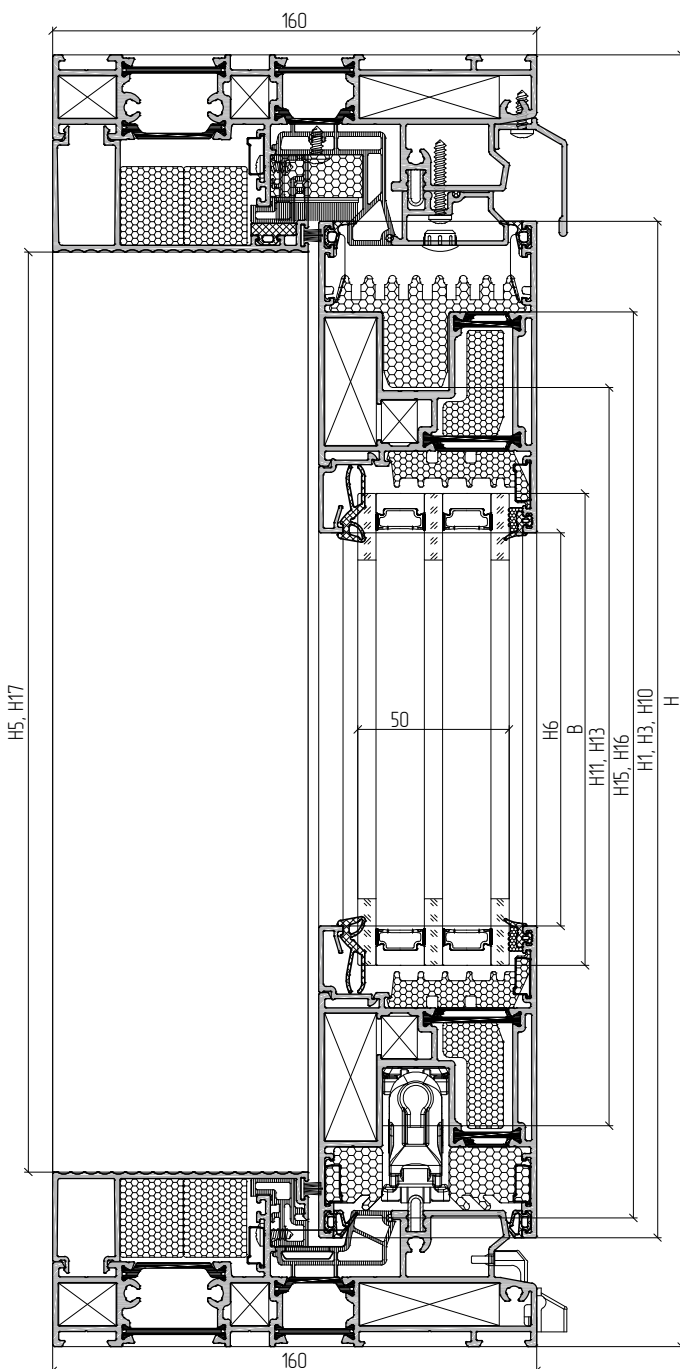

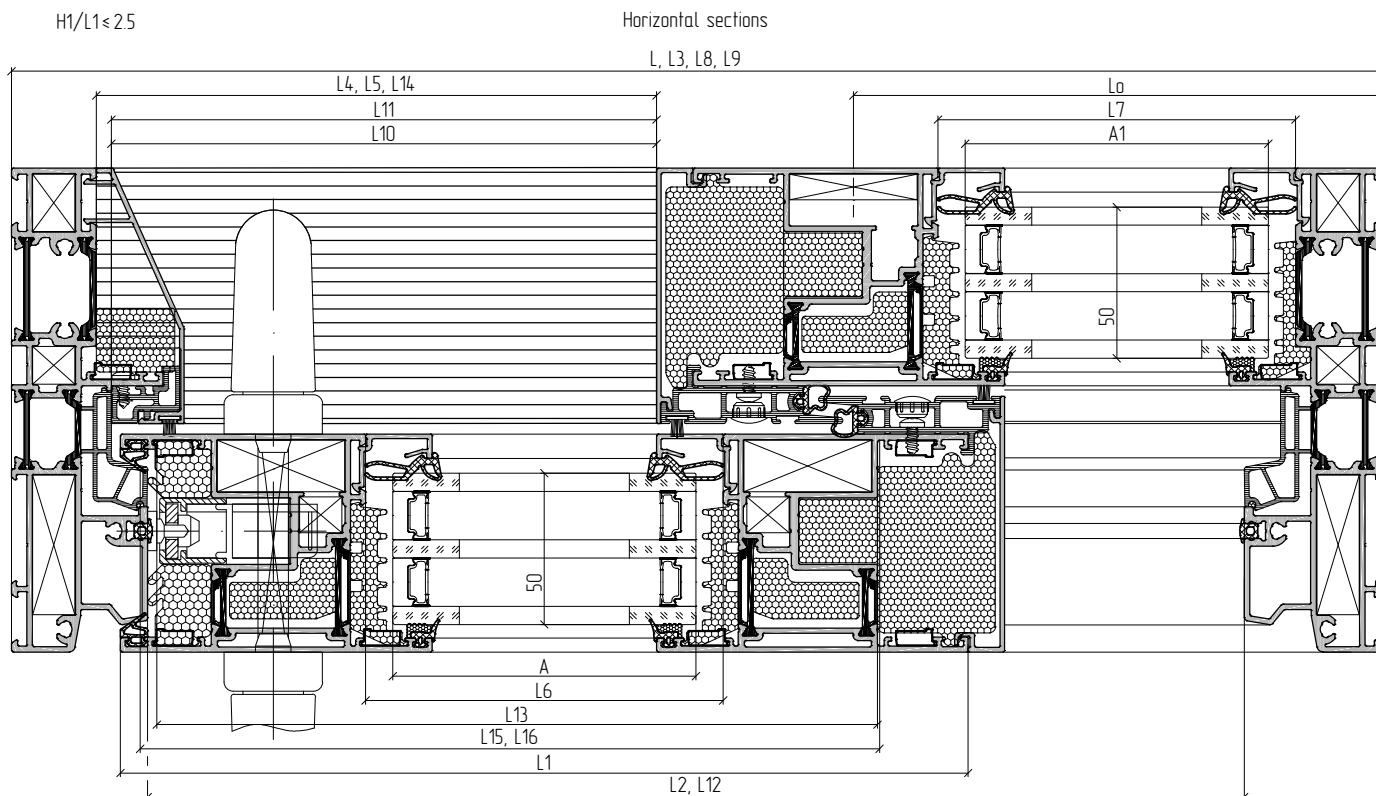

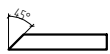
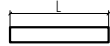
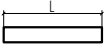



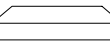

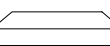
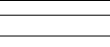
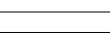
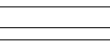
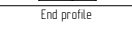
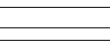
$H1/L1 < 25$

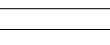

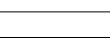
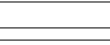

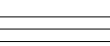
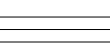
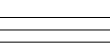



Vertical sections

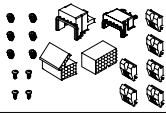



























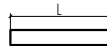
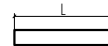

Article	Name Image		Type B1		Type B2	
				1..		1..
Profile						
AYPC.SL160.0102	Frame profile: Double track		L	2	L	2
			H	2	H	2
AYPC.SL160.0202	Sash profile		$L1=L/2+54$	2	$L1=(L+110)/3$	4
			H1=H-91	2	H1=H-91	4
			H2=H-56	1	H2=H-56	2
AYPC.SL160.0801	Guide rail (top)		L2=L-90	1	L2=L-90	1
AYPC.SL160.0802	End profile		H3=H1	1	H3=H1	2
			H4=H2	1	H4=H2	2
AYPC.SL160.0804	Drain profile		L3=L	1	L3=L	1
AYPC.SL160.0806	Threshold profile: Single track		$L4=L/2-41$	1	$L4=L/3-58$	2
AYPC.SL160.0807	Threshold profile: Single track		H5=H-123	1	H5=H-123	2
AYPC.SL160.0808	Threshold profile: Single track		$L5=L/2-41$	1	$L5=L/3-58$	2
AYPC.C48.0602	Glass bead profile		L6=L1-162	2	L6=L1-162	4
			H6=H1-206	2	H6=H1-206	4
			$L7=L/2-108$	2	$L7=L/3-125,4$	2
			H7=H-100	2	H7=H-100	2
AYPC.SL160.0922	Drain profile		* L8=L	1	* L8=L	1

Article	Name Image		Type B1		Type B2	
				1..		1..
Profile						
AYPC.SL160.0923	Drain profile 		** L9=L	1	** L9=L	1
			H8=H-56	2	H8=H-56	2
AYPC.SL160.0924	Drain profile 		L10=L/2-46	1	L10=L/3-63.5	2
			L11=L/2-46	1	L11=L/3-63.5	2
			H9=H-66	1	H9=H-66	2
AYPC.SL160.0938	Interlock 		H10=H1	2	H10=H1	4
AYPC.SL160.1950	Stainless steel track 		L12=L-90	1	L12=L-90	1
			100	L/700	100	L/700
AYPC.SL160.0911	Foamed insert 		L13=L1-42	1	L13=L1-42	2
AYPC.SL160.0912	Foamed insert 		H11=H1-92	1	H11=H1-92	2
			H12=H2	1	H12=H2	2
PE21x26	Thermal insert 		H13=H1-92	1	H13=H1-92	2
			H14=H2	1	H14=H2	2
			L14=L4	4	L14=L4	8
			H17=H5	1	H17=H5	2
AYPC.SL160.0960	Thermal insert 		L15=L1-36	1	L15=L1-36	2
			H15=H1-36	1	H15=H1-36	2
AYPC.SL160.0961	Thermal insert 		L16=L1-36	1	L16=L1-36	2
			H16=H1-36	1	H16=H1-36	2
AYPC.SL160.0947	Rebate insulation 		L17=A1x2+B1-4x100	1	L17=A1x2-2x100	1
AYPC.W72.0911	Rebate insulation 		L18=(A+B)x2-6x100	1	L18=(A+B)x2-6x100	2
			L19=B1-2x100	1	L19=B1x2-4x100	1

Article	Name Image	1..	
		Type B1	Type B2
Accessories			
AYPC.SL160.0940	Ledge kit 	1	2
AYPC.SL160.0942	Sealing block 	1	2
AYPC.SL160.0950	Corner cleat 	8	12
AYPC.SL160.0950-01	Corner cleat 	4	4
AYPC.SL160.0950-02	Corner cleat 	4	4
AYPC.SL160.0951-01	Corner cleat 	4	8
AYPC.W50.1901	Corner cleat 	20	36
AYPC.W62.0951-03	T-cleat 	2	4
AYPC.SL160.0928	Decorative plug 	L2/500+ H10/150	L2/500+ H10/75

Article	Name Image	1..	
		Type B1	Type B2
Accessories			
AYPC.SL160.0943	Encapsulating insert 	2	2
AYPC.SL160.0946	Encapsulating insert 	6	6
AYPC.SL160.0939	Bearing support 	6	6
AYPC.SL160.0949	Bearing support 	6	12
100x56x1(3)	Leveling support 	12(12)	18(18)
AYPC.SL160.0929	Water drain plug 	L/500	L/500
AYPC.C48.0919M-01	Water drain plug 	2	2
FRK177	Rubber corner 	4	8
FRK178	Rubber corner 	2	4
FRK178-01	Rubber corner 	2	4
FRK179	Rubber corner 	8	12

Article	Name Image	1..	
		Type B1	Type B2
Hardware			
3.9x9.5-A2 DIN7981	Self-tapping screw 	H9/300+ L10/300+ L11/300	H9/150+ L10/150+ L11/150
3.9x13-A2 DIN7981	Self-tapping screw 	L3/300	L3/300
3.9x13-A2 DIN7982	Self-tapping screw 	32	40
3.9x25-A2 DIN7981	Self-tapping screw 	L2/500	L2/500
4.2x9.5-A2 DIN7981	Self-tapping screw 	H10/150	H10/75
5x10 DIN6325D	Pin 	8	16

Article	Name Image	Type B1		Type B2	
			1..		1..
Gaskets					
FRK50	Gasket 	H10	2	H10	4
FRK128	Gasket 	L10	1	L10	2
FRK175	Rebate gasket 	L1x2+H1x2	1	L1x2+H1x2	2
FRK176	Gasket 	L1x2	1	L1x2	2
FRK188	Gasket 	H1	2	H1	2
FRK193	Wedge gasket 	(A+B)x2+(A1+B1)x2	1	(A+B)x4+(A1+B1)x2	1
FRK197	Outside gasket 	(A+B)x2+(A1+B1)x2	1	(A+B)x4+(A1+B1)x2	1
AYPC.SL160.0948	Sealing cord 	L2+L8+H8x2+L9	1	L2+L8+H8x2+L9	1
ISE01	Felt sealing 	L4+H5+L5+H10x2	1	L4x2+H5x2+L5x2+H10x4	1

Infill			
Type B1		Type B2	
A=L1-180, B=H1-180	1	A=L1-180, B=H1-180	2
A1=L/2-126, B1=H-74	1	A1=L/3-143.5, B1=H-74	1

The distance to AYPC.W62.0951-03 transom insert axle	
Type B1	Type B2
Lo=L/2-52	Lo=L/3+34.7



- When manufacturing A5 and A6 type doors with the width of 6500 mm it is necessary to install additional frame connectors and encapsulating inserts. (see page 08.52).
 - Select glass bead profile and rubber gaskets according to the infill thickness (see the section 05 - Glazing table).
- * The length of AYPC.SL160.0920 profile is given for calculation of quantity. See dimensions and cutting on page 08.09.
 ** The length of AYPC.SL160.0921 profile is given for calculation of quantity. See dimensions and cutting on page 08.28.

Example of lift and slide door calculations. Type B3

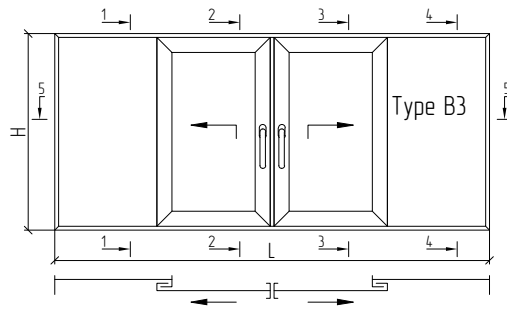

$H1/L1 \leq 25$

1-1

2-2

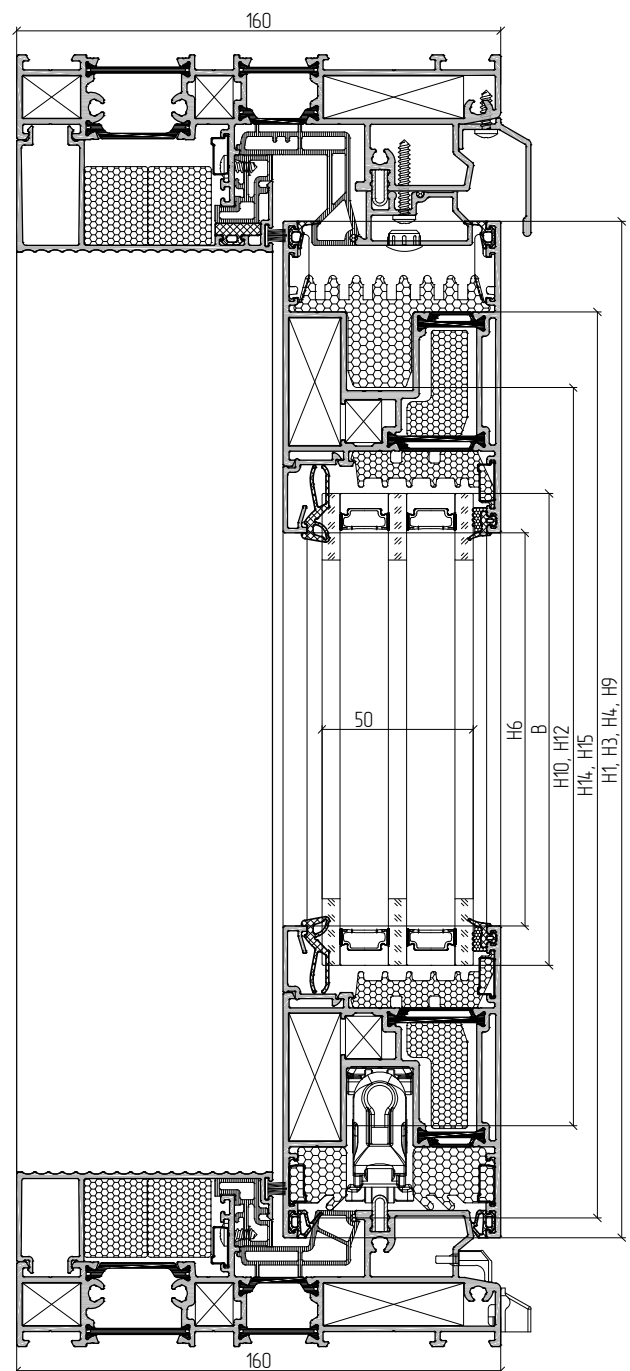
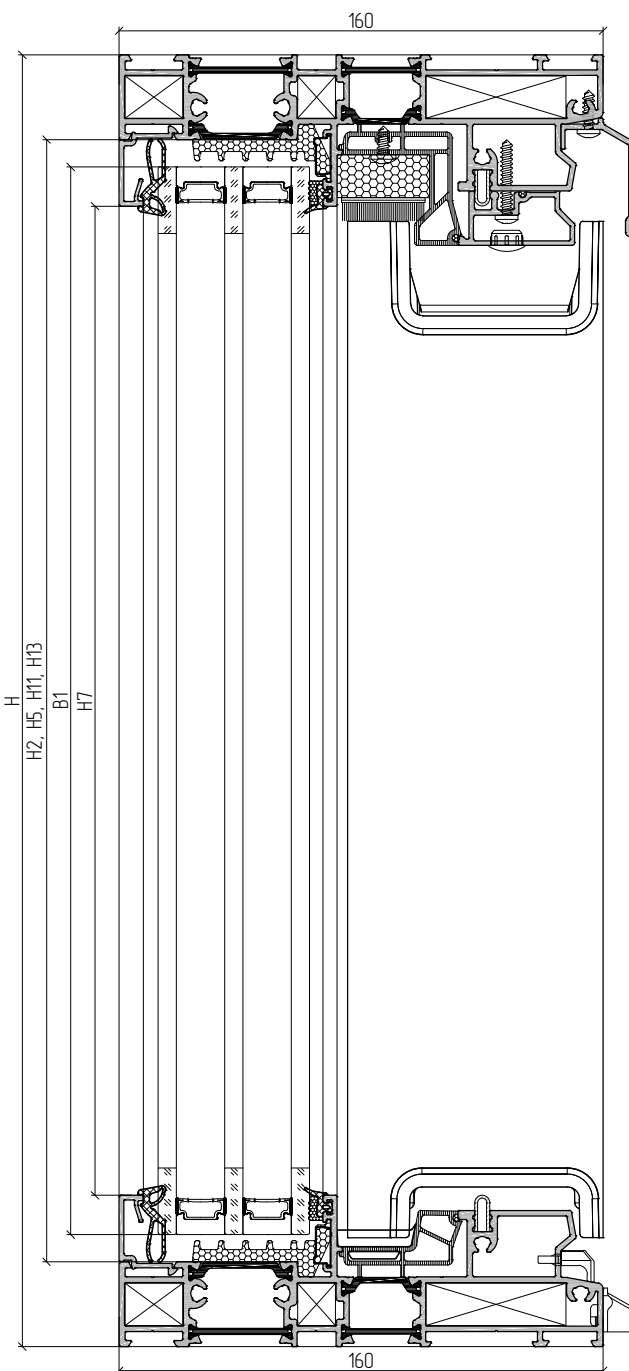

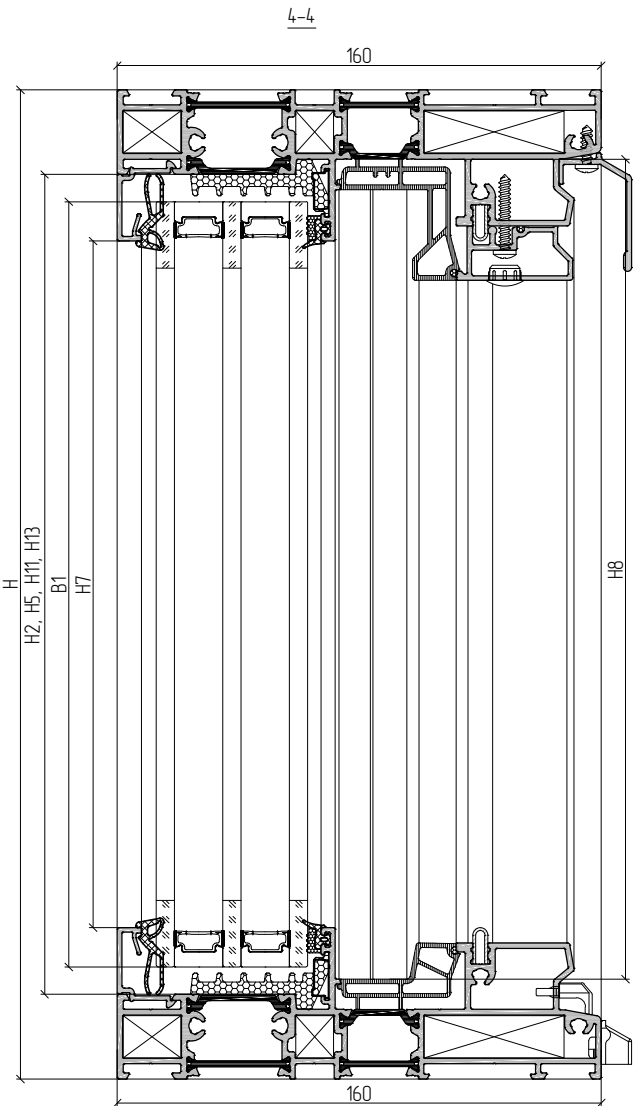
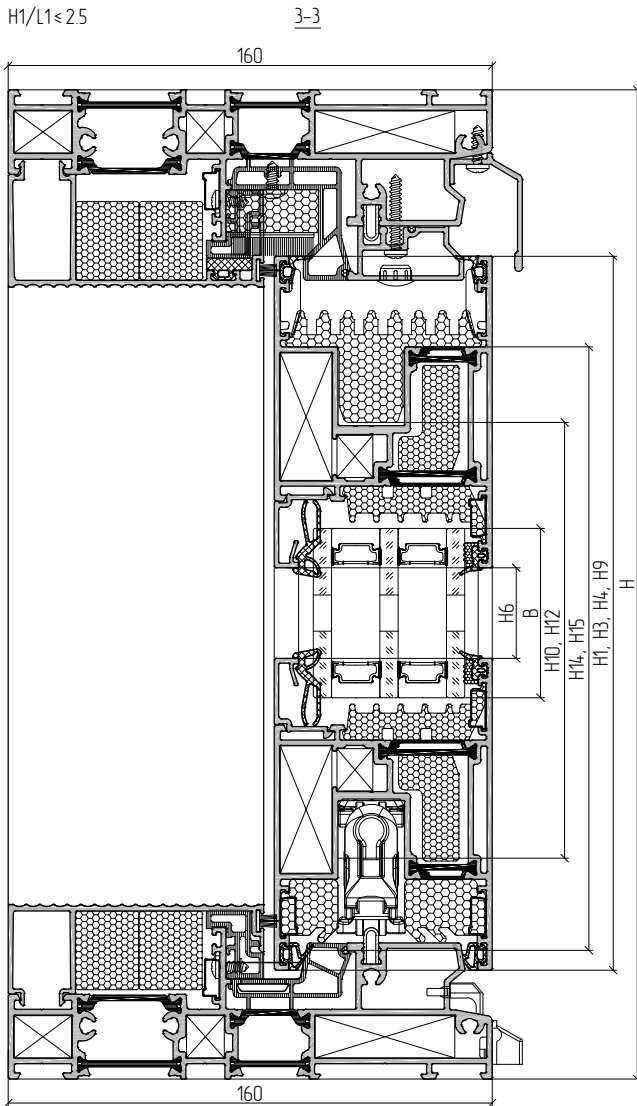





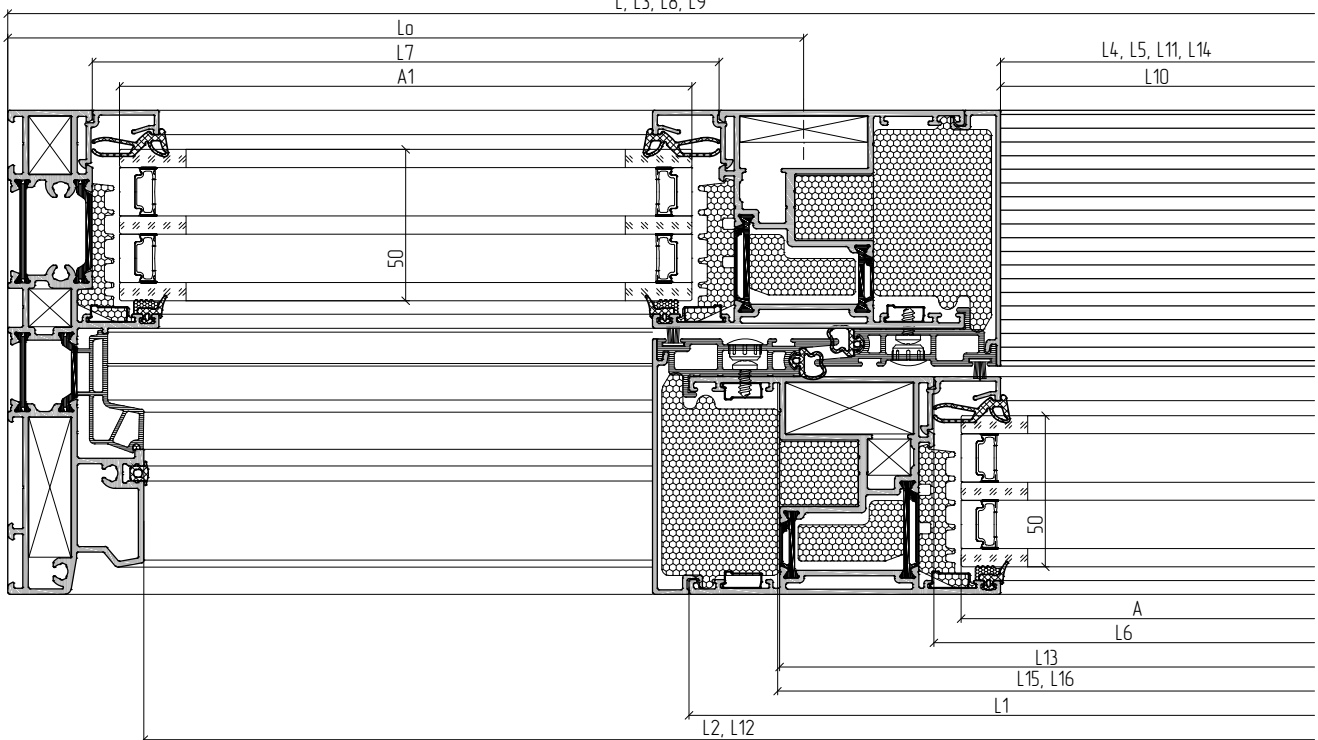



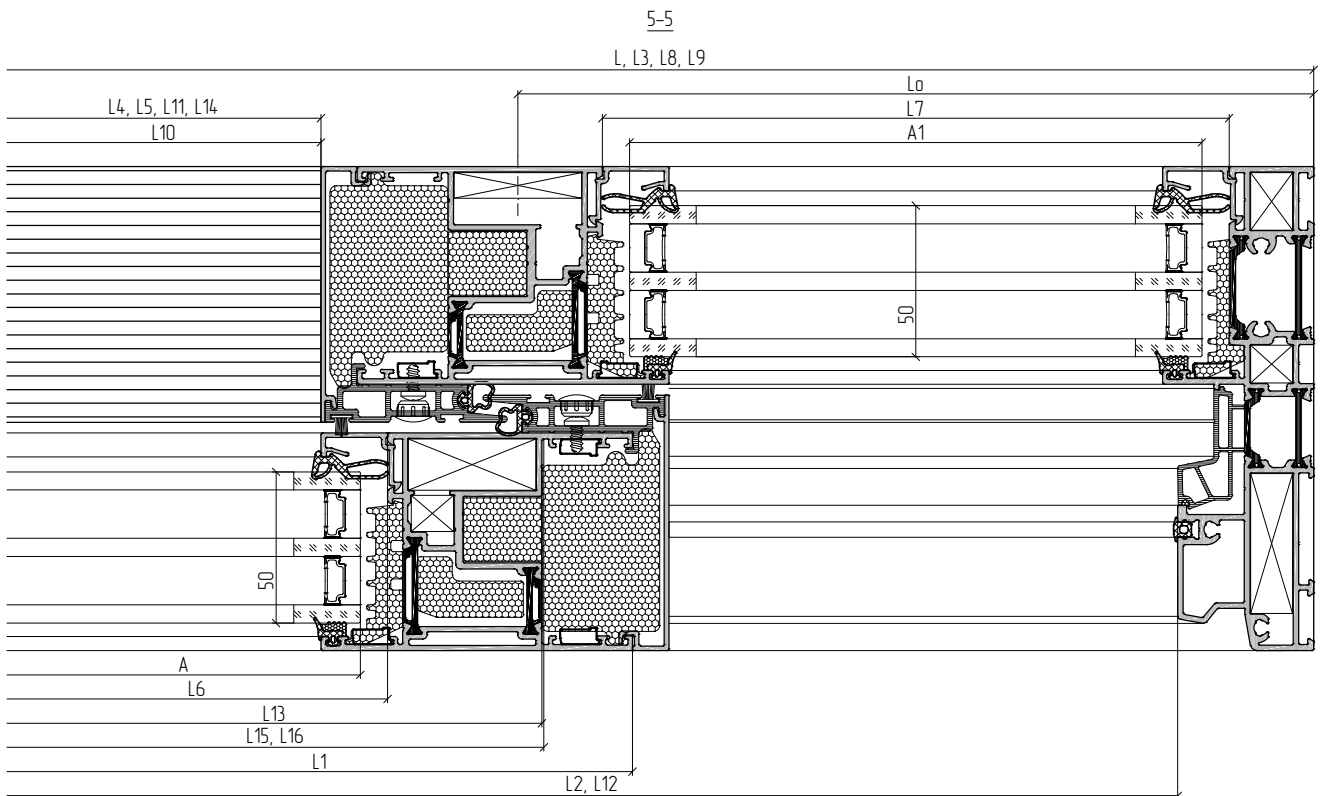
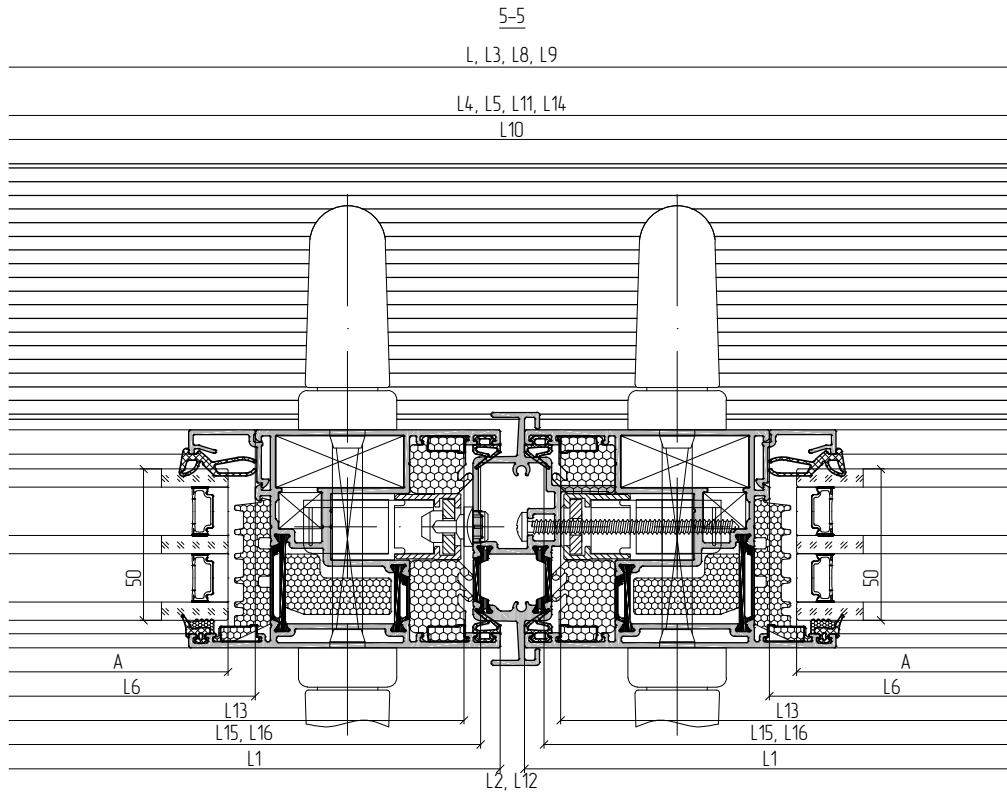

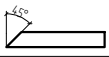
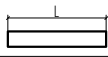

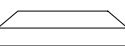
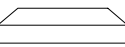

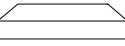

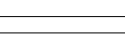

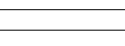



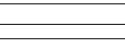
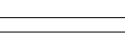

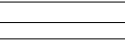





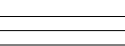
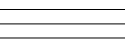
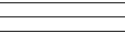
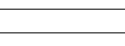

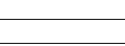

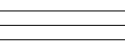
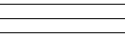

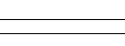
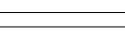

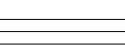
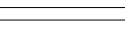

5-5

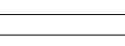

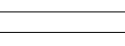
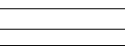

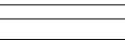
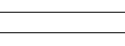
L, L3, L8, L9

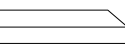

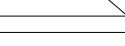
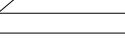

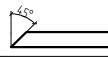
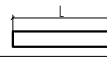

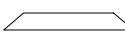

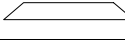
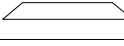

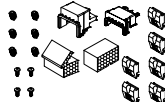
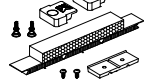

















H1/L1 < 25











Article	Name Image			1..
Profile				
AYPC.SL160.0102	Frame profile: Double track 		L	2
			H	2
AYPC.SL160.0202	Sash profile 		$L1=L/4+70$	4
			$H1=H-91$	4
			$H2=H-56$	2
AYPC.SL160.0504	Interlocking profile 		$H3=H1$	1
AYPC.SL160.0801	Guide rail (top) 		$L2=L-90$	1
AYPC.SL160.0802	End profile 		$H4=H1$	2
			$H5=H2$	2
AYPC.SL160.0804	Drain profile 		$L3=L$	1
AYPC.SL160.0806	Threshold profile: Single track 		$L4=L/2-58$	1
AYPC.SL160.0808	Threshold profile: Single track 		$L5=L/2-58$	1
AYPC.C48.0602	Glass bead profile 		$L6=L1-162$	4
			$H6=H1-206$	4
			$L7=L/4-92$	4
			$H7=H-100$	4
AYPC.SL160.0922	Drain profile 		* $L8=L$	1
AYPC.SL160.0923	Drain profile 		** $L9=L$	1
			$H8=H-56$	2
AYPC.SL160.0924	Drain profile 		$L10=L5$	1
			$L11=L4$	1
AYPC.SL160.0938	Interlock 		$H9=H1$	4
AYPC.SL160.1950	Stainless steel track 		$L12=L-90$	1
			100	L/700
AYPC.SL160.0911	Foamed insert 		$L13=L1-42$	2
AYPC.SL160.0912	Foamed insert 		$H10=H1-92$	2
			$H11=H2$	2
PE21x26	Thermal insert 		$H12=H1-92$	2
			$H13=H2$	2
			$L14=L4$	4
AYPC.SL160.0960	Thermal insert 		$L15=L1-36$	2
			$H14=H1-36$	2
AYPC.SL160.0961	Thermal insert 		$L16=L1-36$	2
			$H15=H1-36$	2

Article	Name Image			1..
Profile				
AYPC.SL160.0947	Rebate insulation 		$L17=A1x2+B1-4x100$	2
AYPC.W72.0911	Rebate insulation 		$L18=(A+B)x2-6x100$	2
			$L19=B1-2x100$	2

Article	Name Image	1..
Accessories		
AYPC.SL160.0940	Ledge kit 	2
AYPC.SL160.0942	Sealing block 	2
AYPC.SL160.0950	Corner cleat 	12
AYPC.SL160.0950-01	Corner cleat 	4
AYPC.SL160.0950-02	Corner cleat 	4
AYPC.SL160.0951-01	Corner cleat 	8
AYPC.W50.1901	Corner cleat 	36
AYPC.W62.0951-03	T-cleat 	4
AYPC.SL160.0928	Decorative plug 	$L2/500+$ $H3/450+$ $H9/75$
AYPC.SL160.0933	Interlocking profile plug 	2
AYPC.SL160.0943	Encapsulating insert 	2
AYPC.SL160.0946	Encapsulating insert 	6
AYPC.SL160.0939	Bearing support 	12
AYPC.SL160.0949	Bearing support 	12
100x56x1(3)	Leveling support 	24(24)
AYPC.SL160.0929	Water drain plug 	L/500
AYPC.C48.0919M-01	Water drain plug 	2
FRK177	Rubber corner 	8
FRK178	Rubber corner 	4
FRK178-01	Rubber corner 	4
FRK179	Rubber corner 	16

Article	Name	Image	1...
Hardware			
3.9x9.5-A2 DIN7981	Self-tapping screw		L10/300+ L11/300
3.9x13-A2 DIN7981	Self-tapping screw		L3/300
3.9x13-A2 DIN7982	Self-tapping screw		44
3.9x25-A2 DIN7981	Self-tapping screw		L2/500
4.2x9.5-A2 DIN7981	Self-tapping screw		H9/75
4.8x70-A2 DIN7981	Self-tapping screw		H3/450
5x10 DIN6325D	Pin		16

Article	Name	Image		1...
Gaskets				
FRK50	Gasket		H9	4
FRK128	Gasket		L10	1
FRK175	Rebate gasket		L1x2+H1x2	2
FRK176	Gasket		L1x2	2
FRK188	Gasket		H1	2
FRK193	Wedge gasket		$(A+B) \times 4 + (A1+B1) \times 4$	1
FRK197	Outside gasket		$(A+B) \times 4 + (A1+B1) \times 4$	1
AYPC.SL160.0948	Sealing cord		$L2+L8+H8 \times 2 + L9$	1
ISE01	Felt sealing		$L4+L5+H9 \times 4$	1

Infill	
$A=L1-180, B=H1-180$	2
$A1=L/4-110, B1=H-74$	2

The distance to AYPC.W62.0951-03 transom insert axle	
$Lo=L/4-36$	



1. When manufacturing A5 and A6 type doors with the width of 6500 mm it is necessary to install additional frame connectors and Encapsulating inserts. (see page 08.52).
 2. Select glass bead profile and rubber gaskets according to the infill thickness (see the section 05 – Glazing table).
- * The length of AYPC.SL160.0920 profile is given for calculation of quantity. See dimensions and cutting on page 08.09.
 ** The length of AYPC.SL160.0921 profile is given for calculation of quantity. See dimensions and cutting on page 08.28.

Example of lift and slide door calculations. Types C1, C3, C4

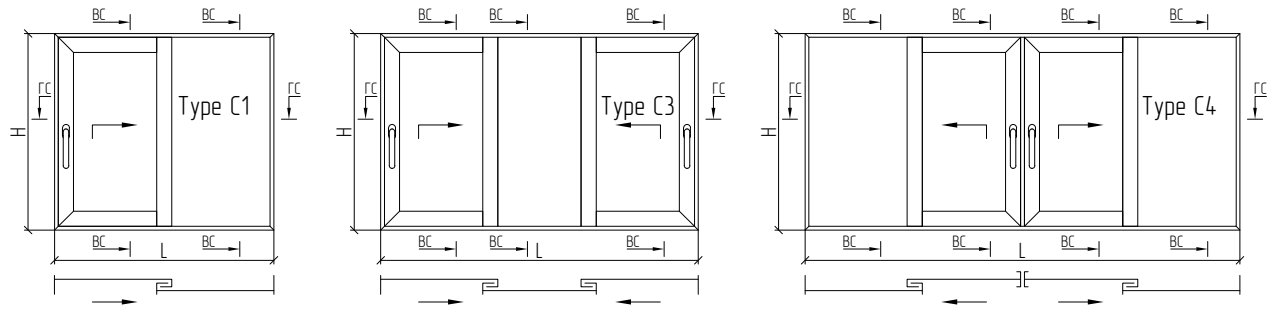

$H1/L1 \leq 25$



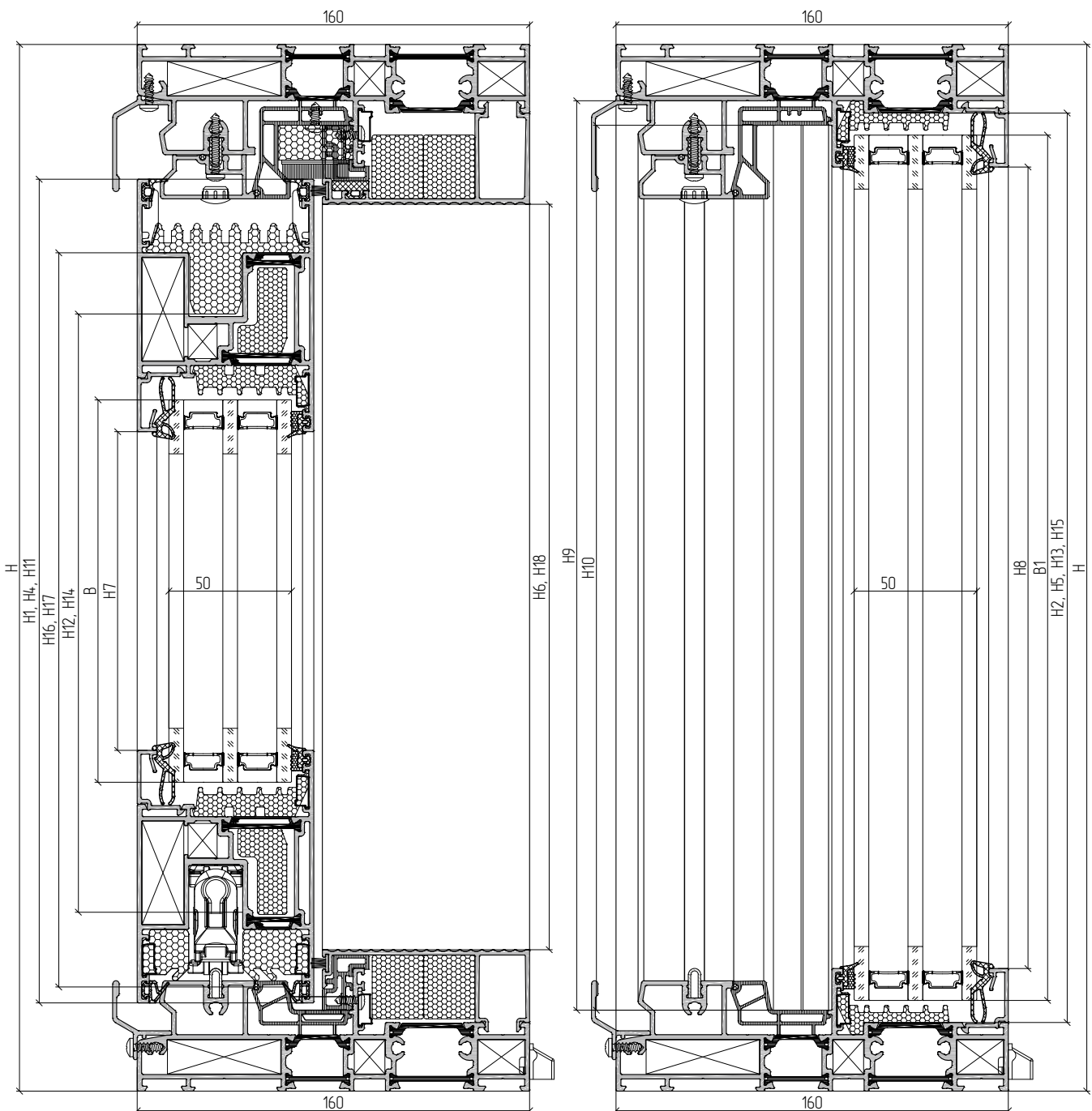





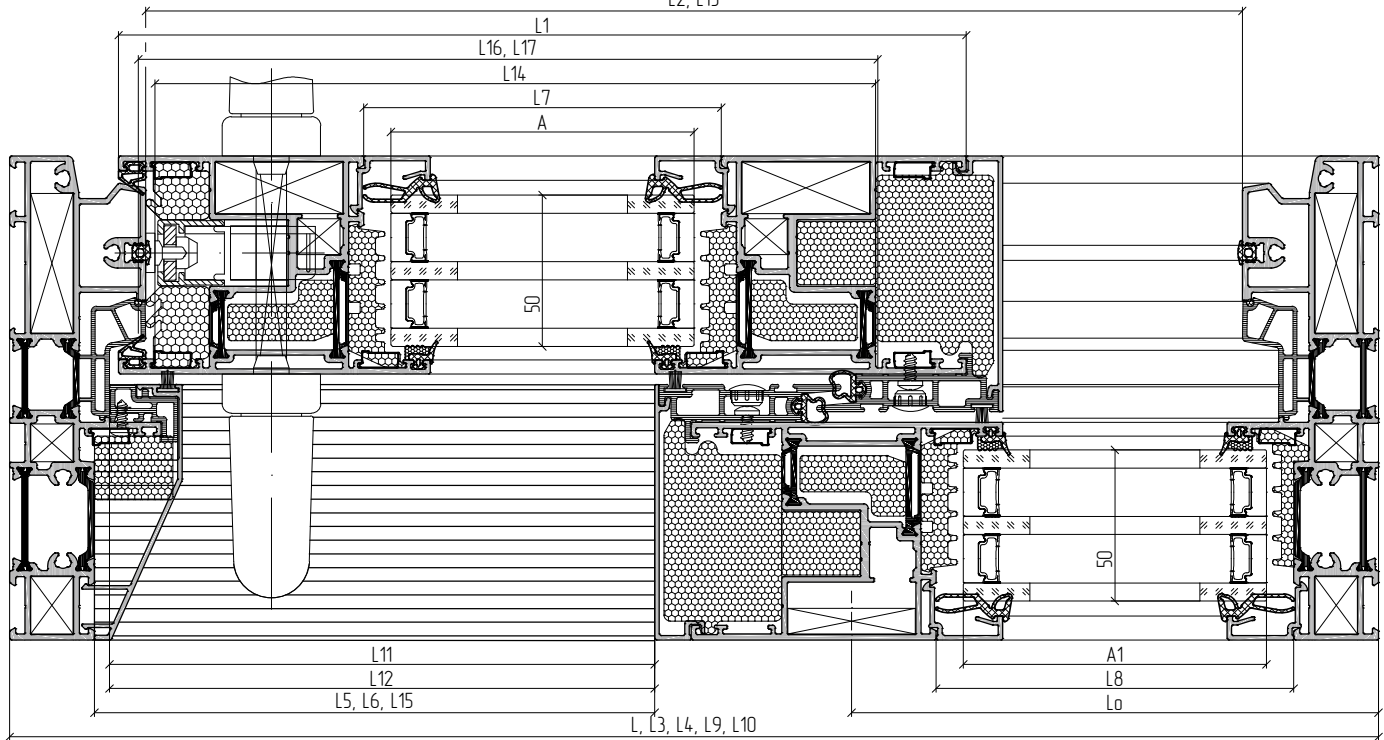

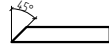
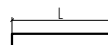
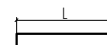
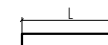

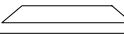
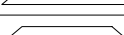
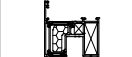
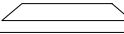
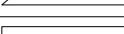

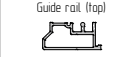
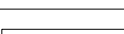
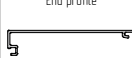
Vertical sections

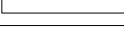

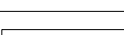
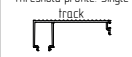



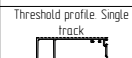
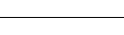
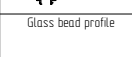

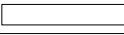

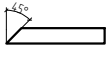
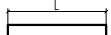
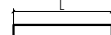
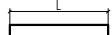





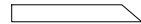
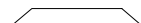



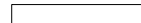
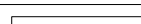



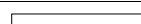



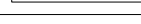
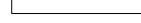

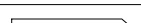

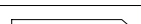





H1/L1 ≤ 25

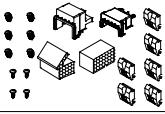









Horizontal sections
L2, L13

















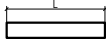
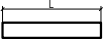
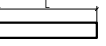

Article	Name Image		Type C1		Type C3		Type C4	
				1..		1..		1..
Profile								
AYPC.SL160.0103	Frame profile Double track 	 	L	2	L	2	L	2
			H	2	H	2	H	2
AYPC.SL160.0202	Sash profile 	 	$L1=L/2+54$	2	$L1=(L+110)/3$	4	$L1=L/4+70$	4
			$H1=H-91$	2	$H1=H-91$	4	$H1=H-91$	4
AYPC.SL160.0504	Interlocking profile 		$H2=H-56$	1	$H2=H-56$	2	$H2=H-56$	2
			-	-	-	-	* $H3=H1$	1
AYPC.SL160.0801	Guide rail (top) 		$L2=L-90$	1	$L2=L-90$	1	$L2=L-90$	1
AYPC.SL160.0802	End profile 		$H4=H1$	1	$H4=H1$	2	$H4=H1$	2
			$H5=H2$	1	$H5=H2$	2	$H5=H2$	2
AYPC.SL160.0804	Drain profile 		$L3=L$	1	$L3=L$	1	$L3=L$	1
AYPC.SL160.0805	Drain profile 		$L4=L$	1	$L4=L$	1	$L4=L$	1
AYPC.SL160.0806	Threshold profile Single track 		$L5=L/2-41$	1	$L5=L/3-58$	2	$L5=L/2-58$	1
AYPC.SL160.0807	Threshold profile Single track 		$H6=H-123$	1	$H6=H-123$	2	-	-
AYPC.SL160.0808	Threshold profile Single track 		$L6=L/2-41$	1	$L6=L/3-58$	2	$L6=L/2-58$	1
AYPC.C48.0602	Glass bead profile 		$L7=L1-162$	2	$L7=L1-162$	4	$L7=L1-162$	4
			$H7=H1-206$	2	$H7=H1-206$	4	$H7=H1-206$	4
			$L8=L/2-108$	2	$L8=L/3-125.4$	2	$L8=L/4-92$	4
			$H8=H-100$	2	$H8=H-100$	2	$H8=H-100$	4
AYPC.SL160.0922	Drain profile 		* $L9=L$	1	* $L9=L$	1	* $L9=L$	1

Article	Name Image		Type C1		Type C3		Type C4	
				1...		1...		1...
AYPC.SL160.0923	Drain profile 		** L10=L	1	** L10=L	1	** L10=L	1
			H9=H-56	2	H9=H-56	2	H9=H-56	2
AYPC.SL160.0924	Drain profile 		L11=L/2-46	1	L11=L/3-63.5	2	L11=L6	1
			L12=L/2-46	1	L12=L/3-63.5	2	L12=L5	1
			H10=H-66	1	H10=H-66	2	-	-
AYPC.SL160.0938	Interlock 		H11=H1	2	H11=H1	4	H11=H1	4
AYPC.SL160.1950	Stainless steel track 		L13=L-90	1	L13=L-90	1	L13=L-90	1
			100	L/700	100	L/700	100	L/700
AYPC.SL160.0911	Foamed insert 		L14=L1-42	1	L14=L1-42	2	L14=L1-42	2
AYPC.SL160.0912	Foamed insert 		H12=H1-92	1	H12=H1-92	2	H12=H1-92	2
			H13=H2	1	H13=H2	2	H13=H2	2
PE21x26	Thermal insert 		H14=H1-92	1	H14=H1-92	2	H14=H1-92	2
			L15=L5	4	L15=L5	8	L15=L5	4
			H15=H2	1	H15=H2	2	H15=H2	2
			H18=H6	1	H18=H6	2	-	-
AYPC.SL160.0960	Thermal insert 		L16=L1-36	1	L16=L1-36	2	L16=L1-36	2
			H16=H1-36	1	H16=H1-36	2	H16=H1-36	2
AYPC.SL160.0961	Thermal insert 		L17=L1-36	1	L17=L1-36	2	L17=L1-36	2
			H17=H1-36	1	H17=H1-36	2	H17=H1-36	2
AYPC.SL160.0947	Rebate insulation 		L18=A1x2+B1-4x100	1	L18=A1x2-2x100	1	L18=A1x2+B1-4x100	2
AYPC.W72.0911	Rebate insulation 		L19=(A+B)x2-6x100	1	L19=(A+B)x2-6x100	2	L19=(A+B)x2-6x100	2
			L20=B1-2x100	1	L20=B1x2-4x100	1	L20=B1-2x100	2

Article	Name Image	1...		
		Type C1	Type C3	Type C4
Accessories				
AYPC.SL160.0940	Ledge kit 	1	2	2
AYPC.SL160.0942	Sealing block 	1	2	2
AYPC.SL160.0950	Corner cleat 	8	12	12
AYPC.SL160.0950-01	Corner cleat 	4	4	4
AYPC.SL160.0950-02	Corner cleat 	4	4	4
AYPC.SL160.0951-01	Corner cleat 	4	8	8
AYPC.W50.1901	Corner cleat 	20	36	36
AYPC.W62.0951-03	T-cleat 	2	4	4
AYPC.SL160.0928	Decorative plug 	L2/500+ H11/150	L2/500+ H11/75	L2/500+ H3/450+ H11/75

Article	Name Image	1...		
		Type C1	Type C3	Type C4
Accessories				
AYPC.SL160.0933	Interlock plug 	-	-	2
AYPC.SL160.0945	Encapsulating insert 	2	2	2
AYPC.SL160.0946	Encapsulating insert 	6	6	6
AYPC.SL160.0939	Bearing support 	6	6	12
AYPC.SL160.0949	Bearing support 	6	12	12
100x56x1(3)	Leveling support 	12(12)	18(18)	24(24)
AYPC.C48.0919M-01	Water drain plug 	L/500	L/500	L/500
FRK177	Rubber corner 	4	8	8
FRK178	Rubber corner 	2	4	4
FRK178-01	Rubber corner 	2	4	4
FRK179	Rubber corner 	8	12	16

Article	Name Image	1..		
		Type C1	Type C3	Type C4
Hardware				
3.9x9.5-A2 DIN7981	Self-tapping screw 	H10/300+ L11/300+ L12/300	H10/150+ L11/150+ L12/150	L11/300+ L12/300
3.9x13-A2 DIN7981	Self-tapping screw 	L3/150	L3/150	L3/150
3.9x13-A2 DIN7982	Self-tapping screw 	32	40	44
3.9x25-A2 DIN7981	Self-tapping screw 	L2/500	L2/500	L2/500
4.2x9.5-A2 DIN7981	Self-tapping screw 	H11/150	H11/75	H11/75
4.8x70-A2 DIN7981	Self-tapping screw 	-	-	H3/450
5x10 DIN6325D	Pin 	8	16	16

Article	Name Image	Type C1		Type C3		Type C4	
			1..		1..		1..
Gaskets							
FRK50	Gasket 	H11	2	H11	4	H11	4
FRK128	Gasket 	L11	1	L11	2	L11	1
FRK175	Rebate gasket 	L1x2+H1x2	1	L1x2+H1x2	2	L1x2+H1x2	2
FRK176	Gasket 	L1x2	1	L1x2	2	L1x2	2
FRK188	Gasket 	H1	2	H1	2	H1	2
FRK193	Wedge gasket 	(A+B)x2+(A1+B1)x2	1	(A+B)x4+(A1+B1)x2	1	(A+B)x4+(A1+B1)x4	1
FRK197	Outside gasket 	(A+B)x2+(A1+B1)x2	1	(A+B)x4+(A1+B1)x2	1	(A+B)x4+(A1+B1)x4	1
AYPC.SL160.0948	Sealing cord 	L2+L9+H9x2+L10	1	L2+L9+H9x2+L10	1	L2+L9+H9x2+L10	1
ISE01	Felt sealing 	L5+H6+L6+H11x2	1	L5x2+H6x2+L6x2+H11x4	1	L5+L6+H11x4	1

Infill					
Type C1		Type C3		Type C4	
A=L1-180, B=H1-180	1	A=L1-180, B=H1-180	2	A=L1-180, B=H1-180	2
A1=L/2-126, B1=H-74	1	A1=L/3-143.5, B1=H-74	1	A1=L/4-110, B1=H-74	2

The distance to AYPC.W62.0951-03 transom insert axle		
Type C1	Type C3	Type C4
Lo=L/2-52	Lo=L/3+34.7	Lo=L/4-36



- When manufacturing A5 and A6 type doors with the width of 6500 mm it is necessary to install additional frame connectors and encapsulating inserts. (see page 08.52).
- Select glass bead profile and rubber gaskets according to the infill thickness (see the section 05 - Glazing table).
 - * The length of AYPC.SL160.0920 profile is given for calculation of quantity. See dimensions and cutting on page 08.09.
 - ** The length of AYPC.SL160.0921 profile is given for calculation of quantity. See dimensions and cutting on page 08.28.

Example of lift and slide door calculations. Type C2

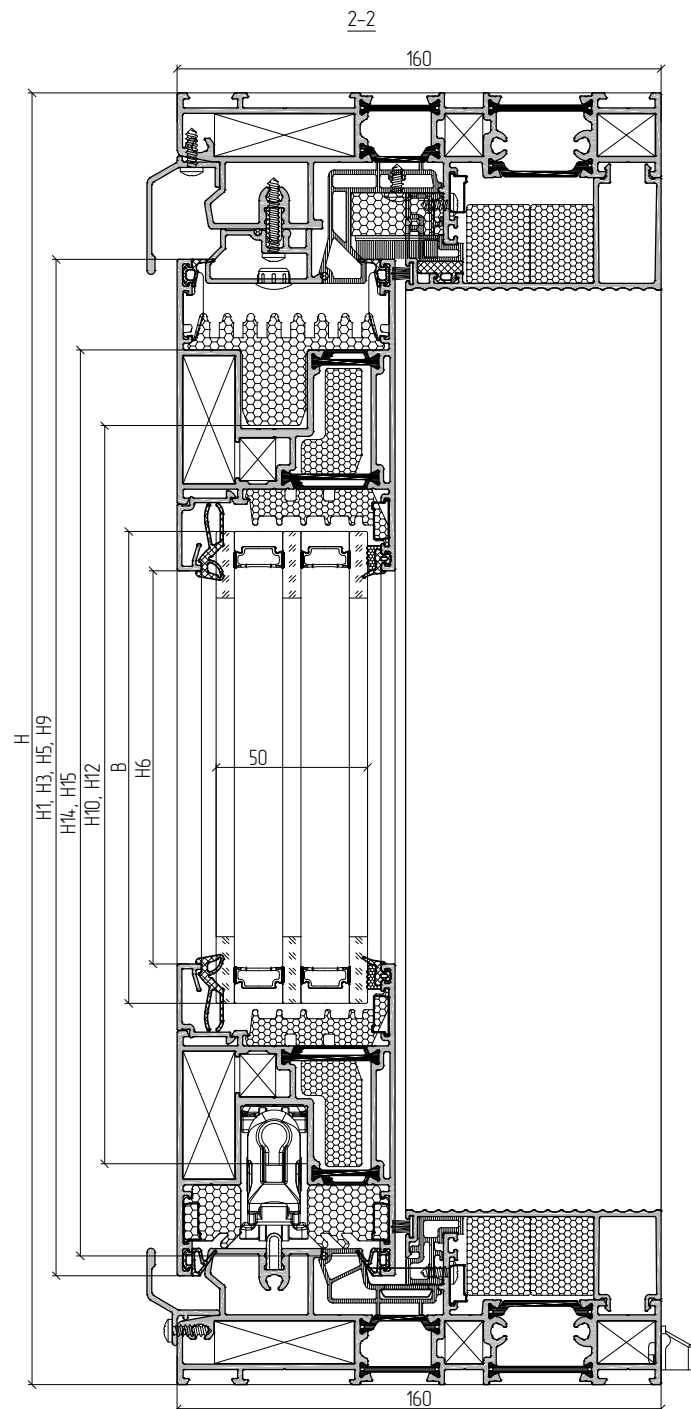
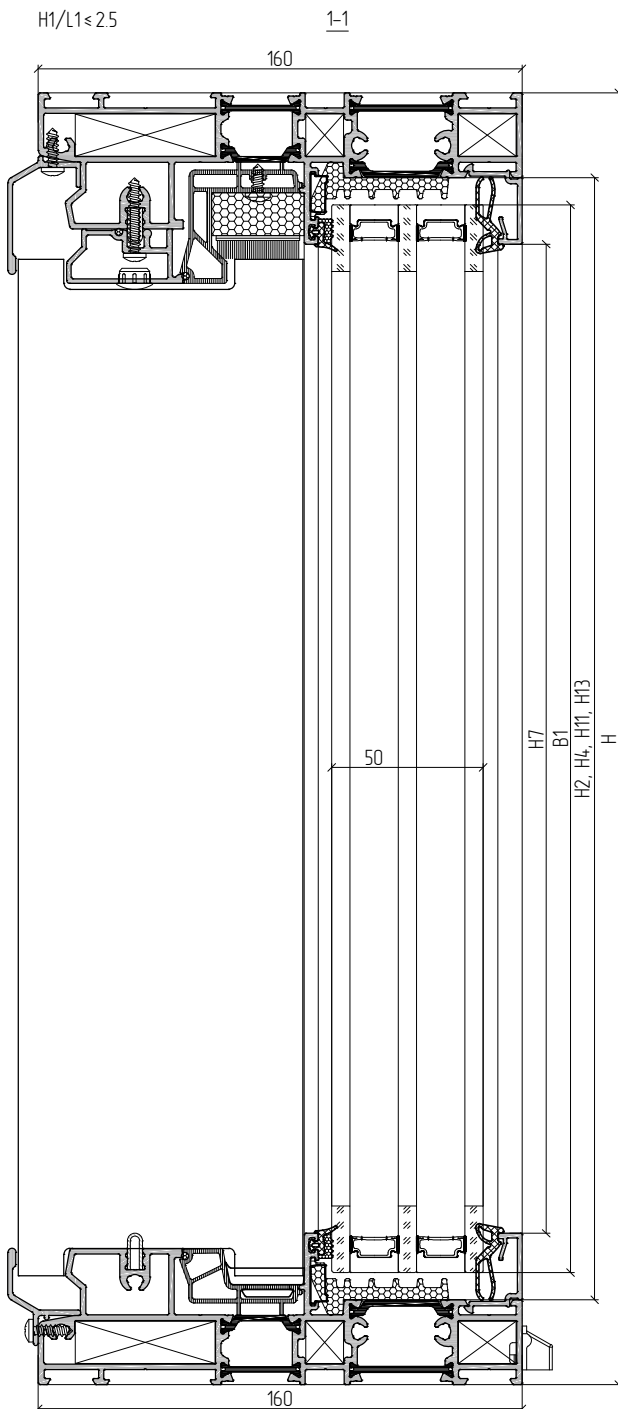
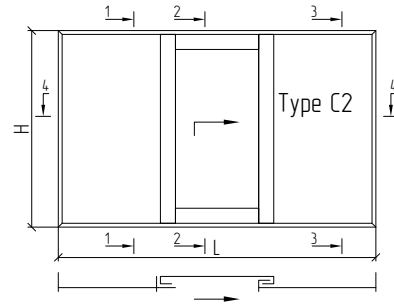

01

02

03

04

05

06

07

08

09

10

$H1/L1 \leq 25$

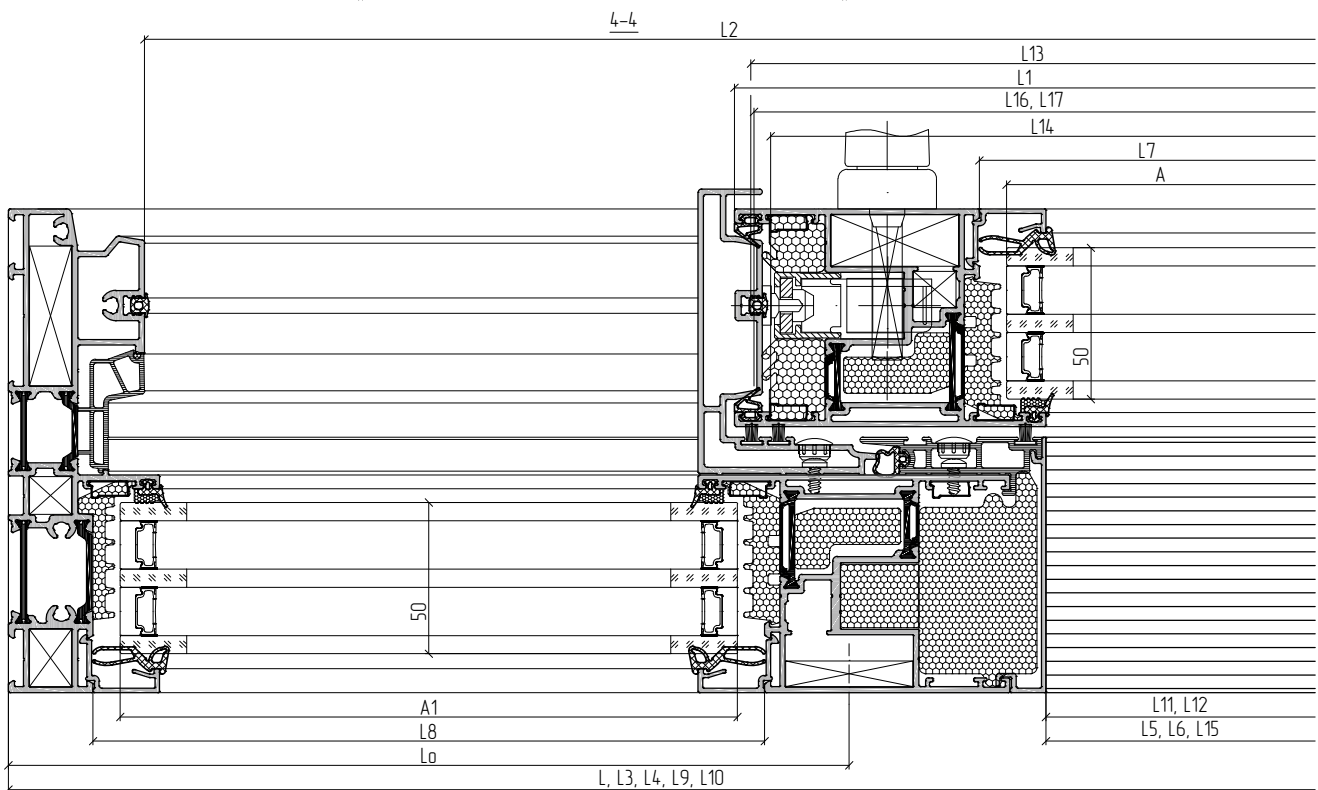
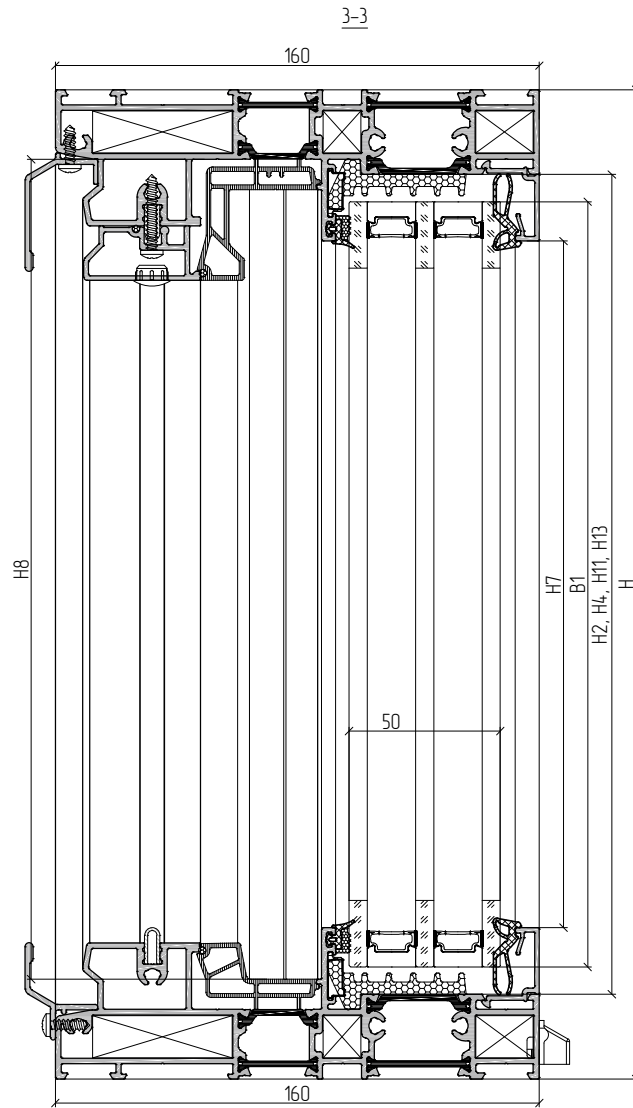

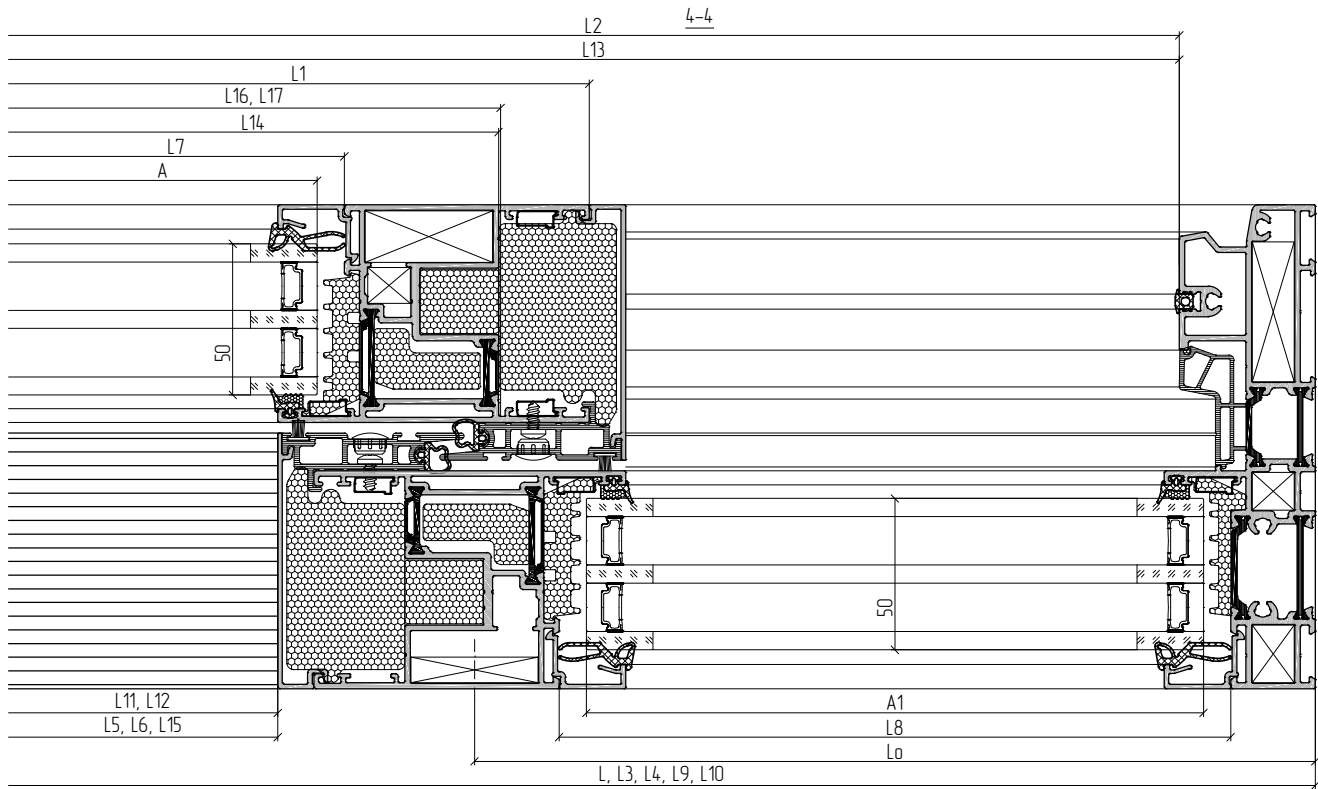

Article	Name	Image			1..
Profile					
AYPC.SL160.0103	Frame profile: Double track			L	2
AYPC.SL160.0202	Sash profile			L1=L/3+96	2
				H1=H-91	2
				H2=H-56	2
AYPC.SL160.0801	Guide rail (top)			L2=L-90	1
AYPC.SL160.0802	End profile			H3=H1	1
				H4=H2	2
AYPC.SL160.0804	Drain profile			L3=L	1
AYPC.SL160.0805	Drain profile			L4=L	1
AYPC.SL160.0806	Threshold profile: Single track			L5=L/3-110	1
AYPC.SL160.0808	Threshold profile: Single track			L6=L/3-110	1
AYPC.SL160.0813	Guide rail (top)			H5=H1	1
AYPC.C48.0602	Glass bead profile			L7=L1-162	2
				H6=H1-206	2
				L8=L/3-66	4
				H7=H-100	4
AYPC.SL160.0922	Drain profile			* L9=L	1

Article	Name	Image			1..
Profile					
AYPC.SL160.0923	Drain profile			** L10=L	1
				H8=H-56	2
AYPC.SL160.0924	Drain profile			L11=L5	1
				L12=L6	1
AYPC.SL160.0938	Interlock			H9=H1	3
AYPC.SL160.1950	Stainless steel track			L13=2L/3-3	1
				100	L/700
AYPC.SL160.0911	Foamed insert			L14=L1-42	1
AYPC.SL160.0912	Foamed insert			H10=H1-92	1
				H11=H2	2
				H12=H1-92	1
PE21x26	Thermal insert			L15=L5	4
				H13=H2	2
				L16=L1-36	1
AYPC.SL160.0960	Thermal insert			H14=H1-36	1
				L17=L1-36	1
AYPC.SL160.0961	Thermal insert			H15=H1-36	1
				L18=A1x2+B1-4x100	2
AYPC.SL160.0947	Rebate insulation			L19=(A+B)x2-6x100	1
AYPC.W72.0911	Rebate insulation			L20=B1-2x100	2

Article	Name	Image	1...
Accessories			
AYPC.SL160.0940	Ledge kit		1
AYPC.SL160.0942	Sealing block		2
AYPC.SL160.0950	Corner cleat		8
AYPC.SL160.0950-01	Corner cleat		4
AYPC.SL160.0950-02	Corner cleat		4
AYPC.SL160.0951-01	Corner cleat		4
AYPC.W50.1901	Corner cleat		24
AYPC.W62.0951-03	T-cleat		4
AYPC.SL160.0928	Decorative plug		L2/500+ H9/75
AYPC.SL160.0945	Encapsulating insert		2
AYPC.SL160.0946	Encapsulating insert		6
AYPC.SL160.0939	Bearing support		12
AYPC.SL160.0949	Bearing support		6
100x56x1(3)	Leveling support		18(18)
AYPC.C48.0919M-01	Water drain plug		L/500
FRK177	Rubber corner		4
FRK178	Rubber corner		2
FRK178-01	Rubber corner		2
FRK179	Rubber corner		12
Hardware			
3.9x9.5-A2 DIN7981	Self-tapping screw		L11/300+ L12/300
3.9x13-A2 DIN7981	Self-tapping screw		L3/150
3.9x13-A2 DIN7982	Self-tapping screw		32
3.9x25-A2 DIN7981	Self-tapping screw		L2/500
4.2x9.5-A2 DIN7981	Self-tapping screw		H9/75
5x10 DIN6325D	Pin		8

Article	Name	Image		1...
Gaskets				
FRK50	Gasket		H9	3
FRK128	Gasket		L6	1
FRK175	Rebate gasket		L1x2+H1x2	1
FRK176	Gasket		L1x2	1
FRK188	Gasket		H1	3
FRK193	Wedge gasket		(A+B)x2+(A1+B1)x4	1
FRK197	Rubber gasket		(A+B)x2+(A1+B1)x4	1
AYPC.SL160.0948	Sealing cord		L2+L9+H8x2+L10	1
ISE01	Felt sealing		L5+L6+H5x2+H9x3	1

Infill		
A=L1-180; B=H1-180		1
A1=L/3-84; B1=H-74		2

The distance to AYPC.W62.0951-03 transom insert axle	
Lo=L/3-10	



- When manufacturing C2 type door with the width $L > 6500$ mm it is necessary to install additional connector and encapsulating inserts (see page 08.53).
- Select glass bead profile and rubber gaskets according to the infill thickness (see the section 05 - Glazing table).
 - * length of AYPC.SL160.0922 profile is given for calculation of quantity. See dimensions and cutting on page 08.29.
 - ** length of AYPC.SL160.0923 profile is given for calculation of quantity. See dimensions and cutting on page 08.11.

Example of lift and slide door calculations. Types D1, D2, D3, D4

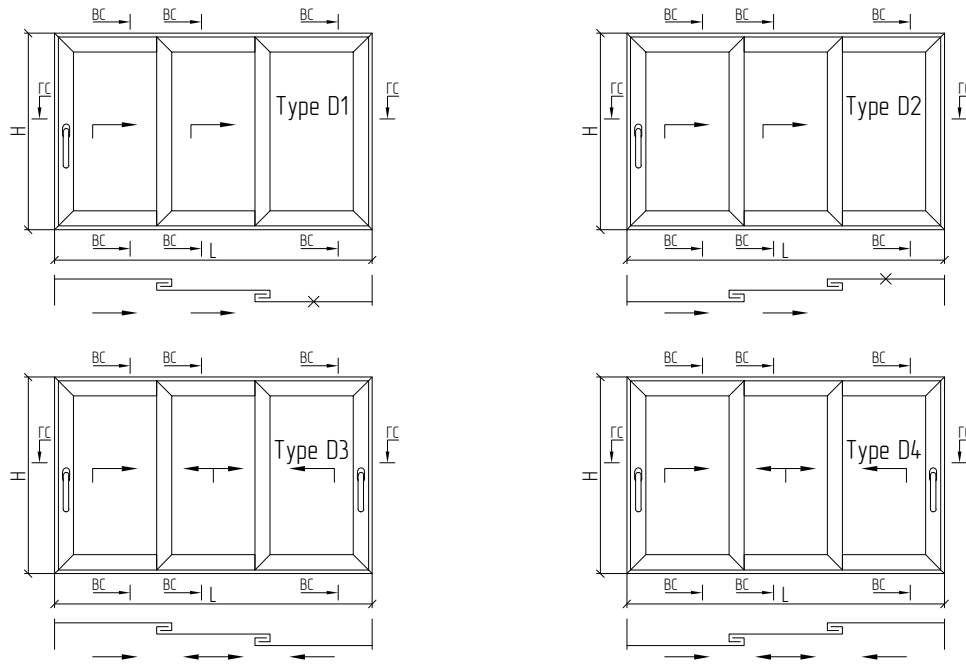

$H1/L1 \leq 25$



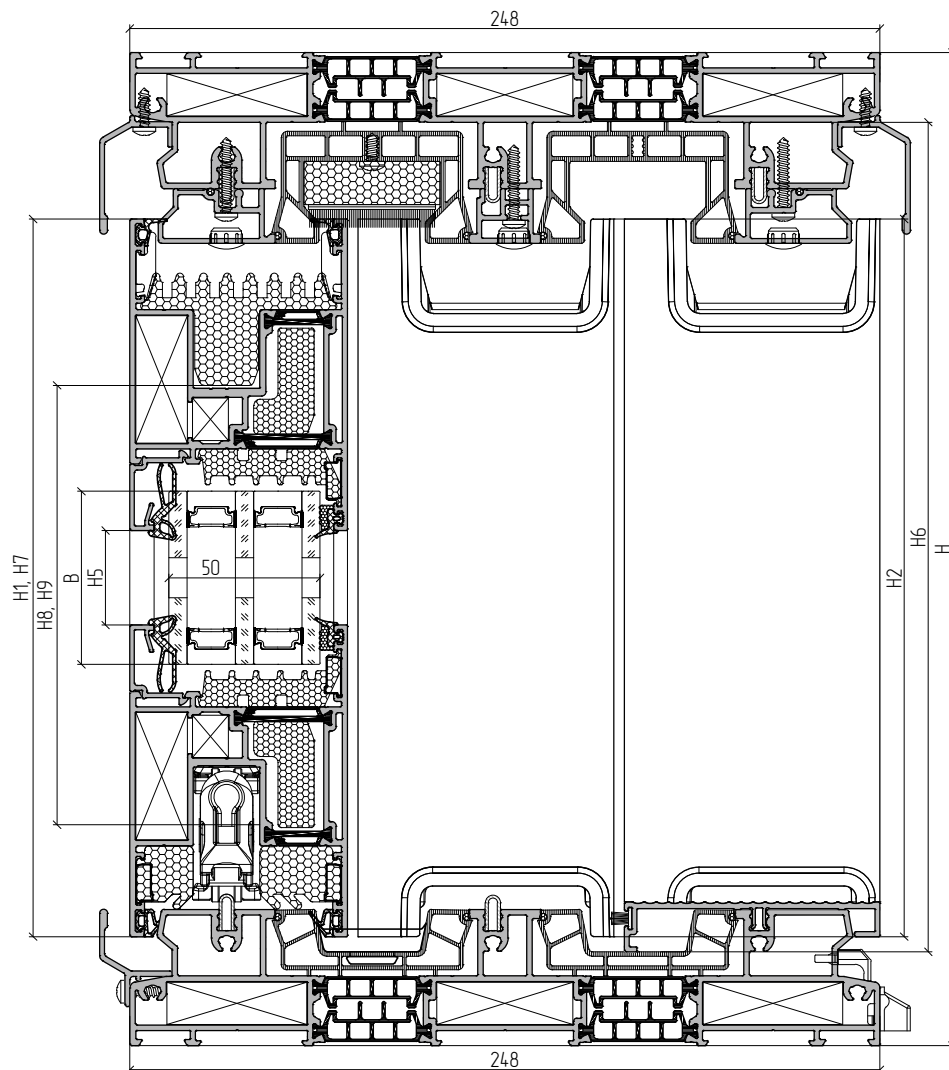





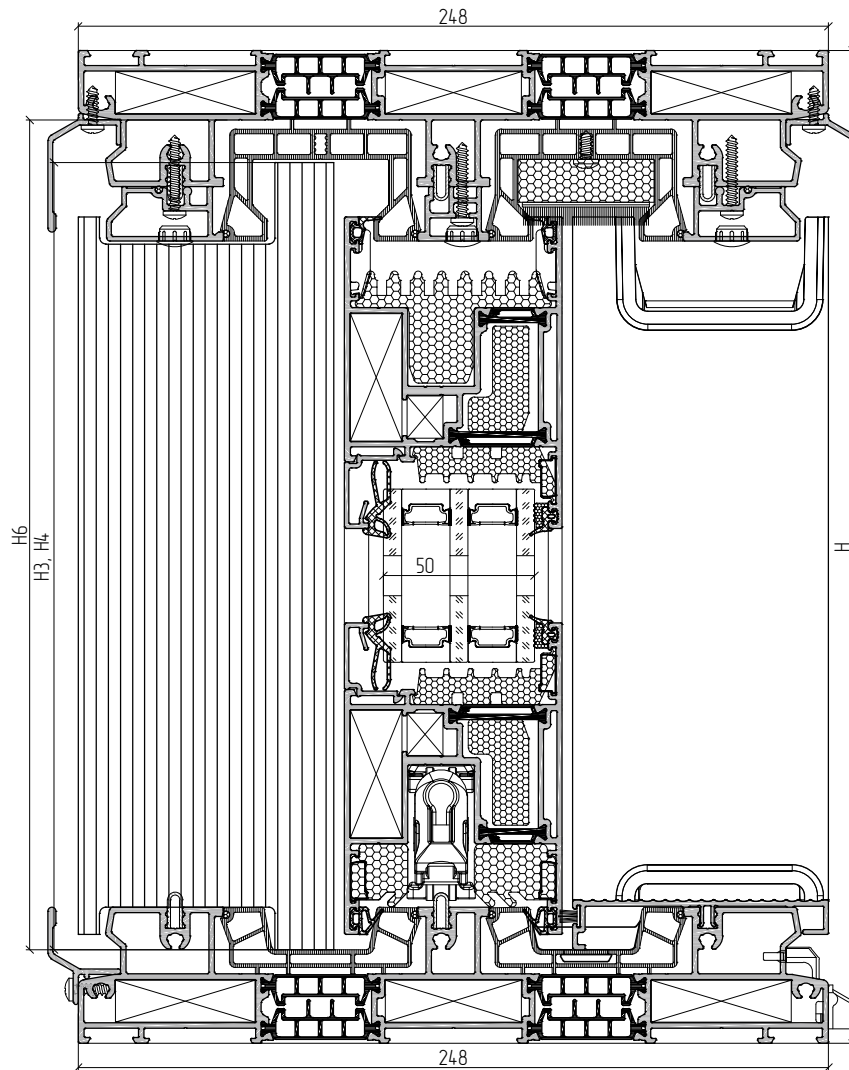

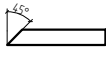
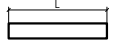
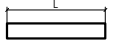
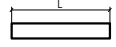
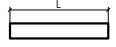
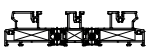

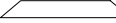

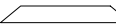



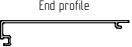

Vertical sections

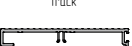

H1/L1 ≤ 25

Vertical sections









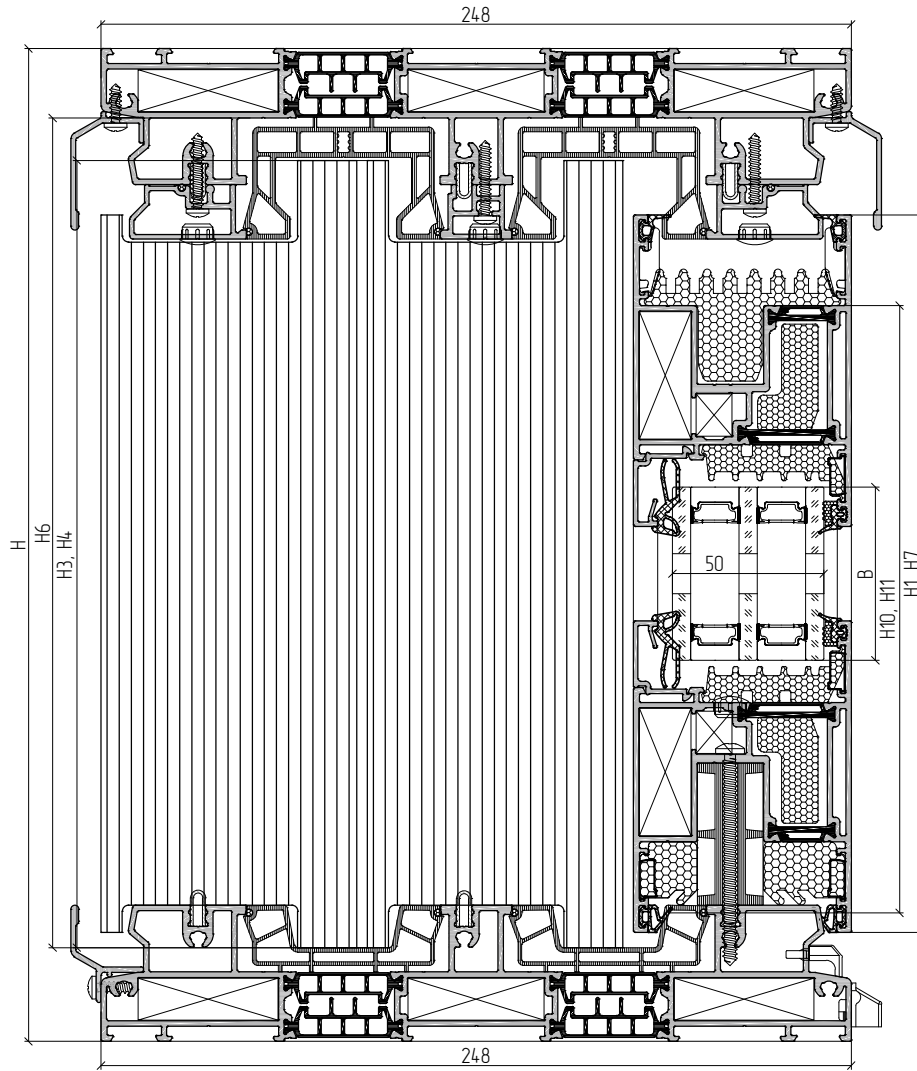

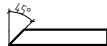
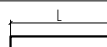
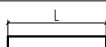
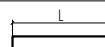
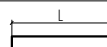

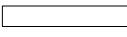

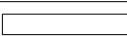





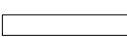

Article	Name Image		Type D1		Type D2		Type D3		Type D4	
				1..		1..		1..		1..
Profile										
AYPC.SL160.0104	Frame profile: Double track 		L	2	L	2	L	2	L	2
			H	2	H	2	H	2	H	2
AYPC.SL160.0202	Sash profile 		$L1=(L+110)/3$	6	$L1=(L+110)/3$	6	$L1=(L+110)/3$	6	$L1=(L+110)/3$	6
			H1=H-91	6	H1=H-91	6	H1=H-91	6	H1=H-91	6
AYPC.SL160.0801	Guide rail (top) 		L2=L-90	2	L2=L-90	2	L2=L-90	2	L2=L-90	2
AYPC.SL160.0802	End profile 		H2=H1	4	H2=H1	4	H2=H1	4	H2=H1	4
AYPC.SL160.0804	Drain profile 		L3=L	2	L3=L	2	L3=L	2	L3=L	2
AYPC.SL160.0805	Drain profile 		L4=L	1	L4=L	1	L4=L	1	L4=L	1
AYPC.SL160.0810	Threshold profile: Double/triple track 		$L5=2L/3-134$	1	-	-	-	-	-	-
			H3=H-68	2	H3=H-68	2	H3=H-68	2	H3=H-68	2
AYPC.SL160.0811	Threshold profile: Double/triple track 		-	-	$L6=2L/3-134$	1	-	-	-	-
			H4=H-68	2	H4=H-68	2	H4=H-68	2	H4=H-68	2

H1/L1 ≤ 25

Vertical sections

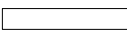

Article	Name Image		Type D1		Type D2		Type D3		Type D4	
				1..		1..		1..		1..
Profile										
AYPC.SL160.0812	Guide rail (top) 		L7=L-90	1	L7=L-90	1	L7=L-90	1	L7=L-90	1
AYPC.C48.0602	Glass bead profile 		L8=L1-162	6	L8=L1-162	6	L8=L1-162	6	L8=L1-162	6
			H5=H1-206	6	H5=H1-206	6	H5=H1-206	6	H5=H1-206	6
AYPC.SL160.0920	Drain profile 		* L9=L	2	* L9=L	2	* L9=L	2	* L9=L	2
			H6=H-54	4	H6=H-54	4	H6=H-54	4	H6=H-54	4
AYPC.SL160.0921	Drain profile 		** L10=L	2	** L10=L	2	** L10=L	2	** L10=L	2
AYPC.SL160.0938	Interlock 		H7=H1	4	H7=H1	4	H7=H1	4	H7=H1	4
AYPC.SL160.1950	Stainless steel track 		L11=L-95	2	L11=L-95	2	L11=L-95	3	L11=L-95	3
			100	L/170	100	L/170	100	L/170	100	L/170
AYPC.SL160.0911	Foamed insert 		L12=L1-42	3	L12=L1-42	3	L12=L1-42	3	L12=L1-42	3
AYPC.SL160.0912	Foamed insert 		H8=H1-92	3	H8=H1-92	3	H8=H1-92	3	H8=H1-92	3
PE21x26	Thermal insert 		H9=H1-92	3	H9=H1-92	3	H9=H1-92	3	H9=H1-92	3

H1/L1 ≤ 25

Horizontal sections

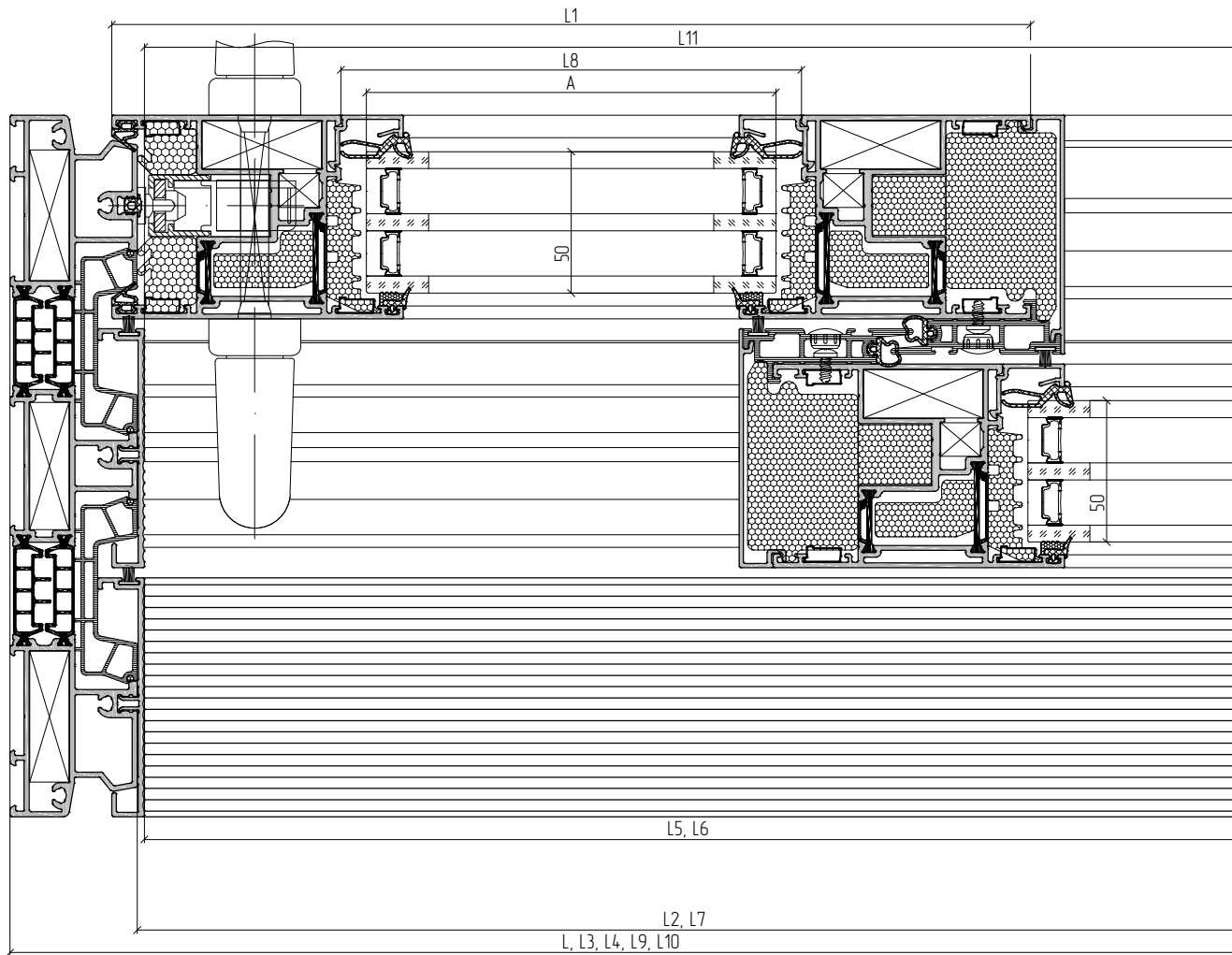

Article	Name Image		Type D1		Type D2		Type D3		Type D4	
				1..		1..		1..		1..
Profile										
AYPC.SL160.0960	Thermal insert 		L13=L1-36	3	L13=L1-36	3	L13=L1-36	3	L13=L1-36	3
			H10=H1-36	3	H10=H1-36	3	H10=H1-36	3	H10=H1-36	3
AYPC.SL160.0961	Thermal insert 		L14=L1-36	3	L14=L1-36	3	L14=L1-36	3	L14=L1-36	3
			H11=H1-36	3	H11=H1-36	3	H11=H1-36	3	H11=H1-36	3
AYPC.W72.0911	Rebate insulation 		L15=(A+B)x2-6x100	3	L15=(A+B)x2-6x100	3	L15=(A+B)x2-6x100	3	L15=(A+B)x2-6x100	3







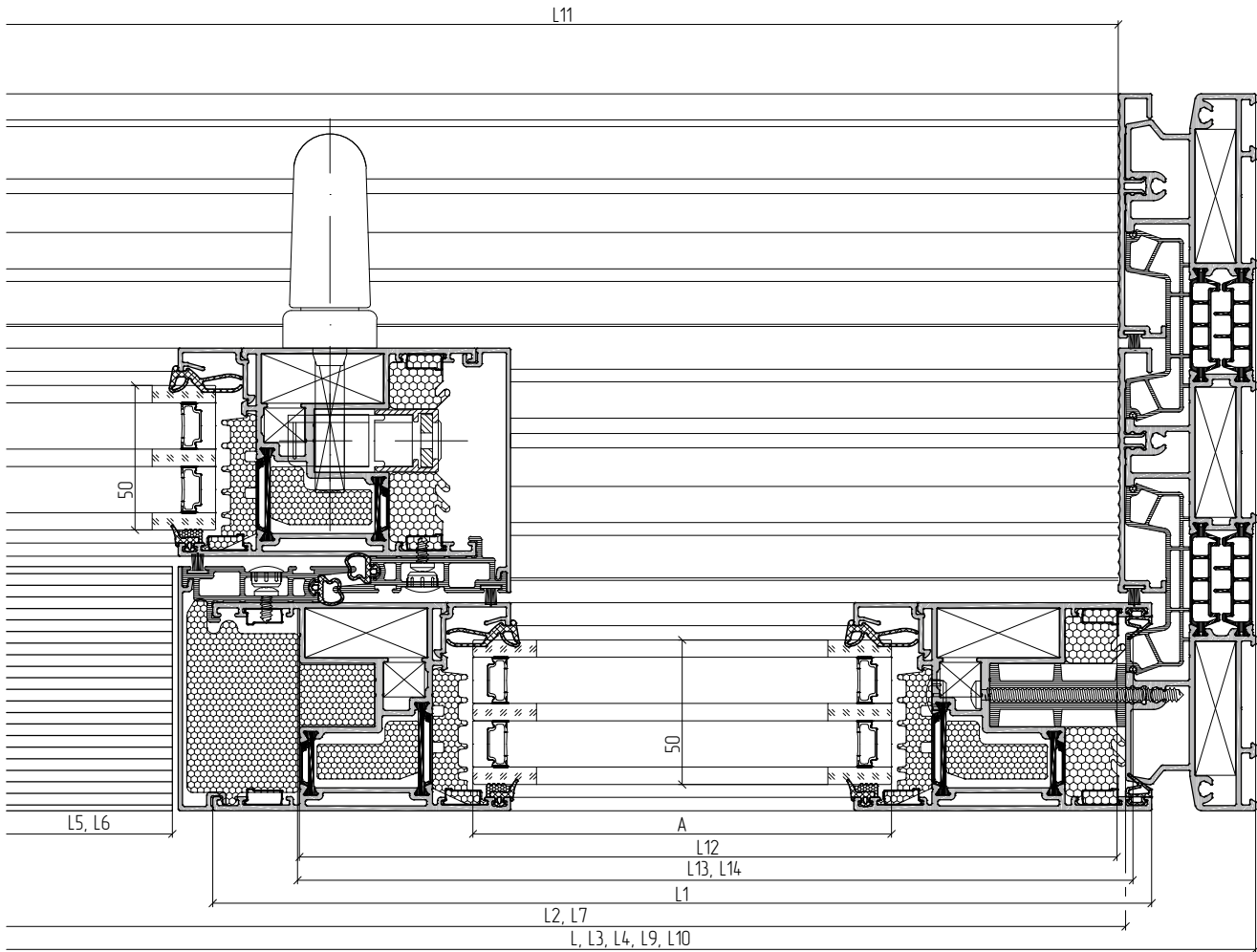







Article	Name Image	1..			
		Type D1	Type D2	Type D3	Type D4
Accessories					
AYPC.SL160.0940	Ledge kit 	4	4	4	4
AYPC.SL160.0941	Sealing block 	2	2	2	2







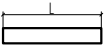
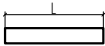
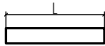
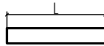

H1/L1 ≤ 25

Horizontal sections



Article	Name	Image	1..			
			Type D1	Type D2	Type D3	Type D4
Accessories						
AYPC.SL160.0950	Corner cleat		12	12	12	12
AYPC.SL160.0950-01	Corner cleat		8	8	8	8
AYPC.SL160.0950-03	Corner cleat		4	4	4	4
AYPC.SL160.0951-01	Corner cleat		12	12	12	12
AYPC.W50.1901	Corner cleat		36	36	36	36
AYPC.SL160.0905	Fixator		4	4	-	-
AYPC.SL160.0928	Decorative plug		L2/250+L7/500+ H7/75+4	L2/250+L7/500+ H7/75+4	L2/250+L7/500+ H7/75	L2/250+L7/500+ H7/75
AYPC.SL160.0943	Encapsulating insert		2	2	2	2
AYPC.SL160.0944	Encapsulating insert		2	2	2	2
AYPC.SL160.0945	Encapsulating insert		2	2	2	2
AYPC.SL160.0946	Encapsulating insert		6	6	6	6
AYPC.SL160.0949	Bearing support		18	18	18	18

Article	Name Image	1...			
		Type D1	Type D2	Type D3	Type D4
Accessories					
100x56x1(3)	Leveling support 	18(18)	18(18)	18(18)	18(18)
AYPC.SL160.0929	Water drain plug 	L/500	L/500	L/500	L/500
AYPC.C48.0919M-01	Water drain plug 	2	2	2	2
FRK177	Rubber corner 	12	12	12	12
FRK178	Rubber corner 	6	6	6	6
FRK178-01	Rubber corner 	6	6	6	6
FRK179	Rubber corner 	12	12	12	12
Hardware					
3.9x13-A2 DIN7981	Self-tapping screw 	L3/100	L3/100	L3/100	L3/100
3.9x13-A2 DIN7982	Self-tapping screw 	48	48	48	48
3.9x25-A2 DIN7981	Self-tapping screw 	L2/150	L2/150	L2/150	L2/150
4.2x9.5-A2 DIN7981	Self-tapping screw 	H7/75	H7/75	H7/75	H7/75
4.8x32-A2 DIN7981	Self-tapping screw 	8	8	-	-
4.8x70-A2 DIN7981	Self-tapping screw 	4	4	-	-
5x10 DIN6325D	Pin 	24	24	24	24

Article	Name Image	Type D1		Type D2		Type D3		Type D4	
			1...		1...		1...		1...
Gaskets									
FRK50	Gasket 	H7	4	H7	4	H7	4	H7	4
FRK175	Rebate gasket 	L1x3+H1x2	2	L1x3+H1x2	2	L1x3+H1x2	2	L1x3+H1x2	2
FRK176	Gasket 	L1x2	3	L1x2	3	L1x2	3	L1x2	3
FRK188	Gasket 	H1	1	H1	1	H1	2	H1	2
FRK193	Wedge gasket 	(A+B)x2	3	(A+B)x2	3	(A+B)x2	3	(A+B)x2	3
FRK197	Outside gasket 	(A+B)x2	3	(A+B)x2	3	(A+B)x2	3	(A+B)x2	3
AYPC.SL160.0948	Sealing cord 	L2x2+H6x8+L9x4+L10x4	1	L2x2+H6x8+L9x4+L10x4	1	L2x2+H6x8+L9x4+L10x4	1	L2x2+H6x8+L9x4+L10x4	1
ISE01	Felt sealing 	H3x2+L5+H4x2+H7x4	1	H3x2+L5+H4x2+H7x4	1	H3x2+H4x2+H7x4	1	H3x2+H4x2+H7x4	1

Infill							
Type D1		Type D2		Type D3		Type D4	
A=L1-180; B=H1-180	3	A=L1-180; B=H1-180	3	A=L1-180; B=H1-180	3	A=L1-180; B=H1-180	3



- When manufacturing C2 type door with the width $L > 6500$ mm it is necessary to install additional connector and encapsulating inserts (see page 08.53).
- Select glass bead profile and rubber gaskets according to the infill thickness (see the section 05 - Glazing table).
 - * length of AYPC.SL160.0922 profile is given for calculation of quantity. See dimensions and cutting on page 08.29.
 - ** length of AYPC.SL160.0923 profile is given for calculation of quantity. See dimensions and cutting on page 08.11.

Example of lift and slide door calculations. Types D5, D6, D7, D8

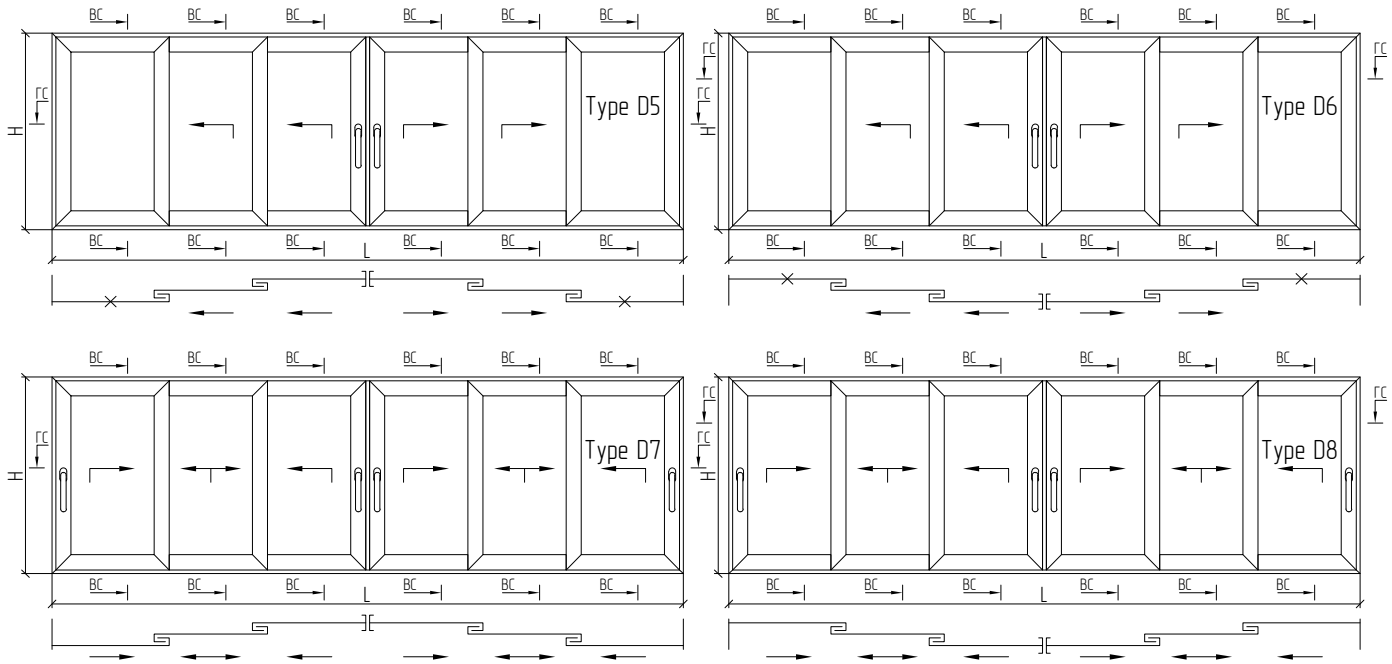

$H1/L1 \leq 25$



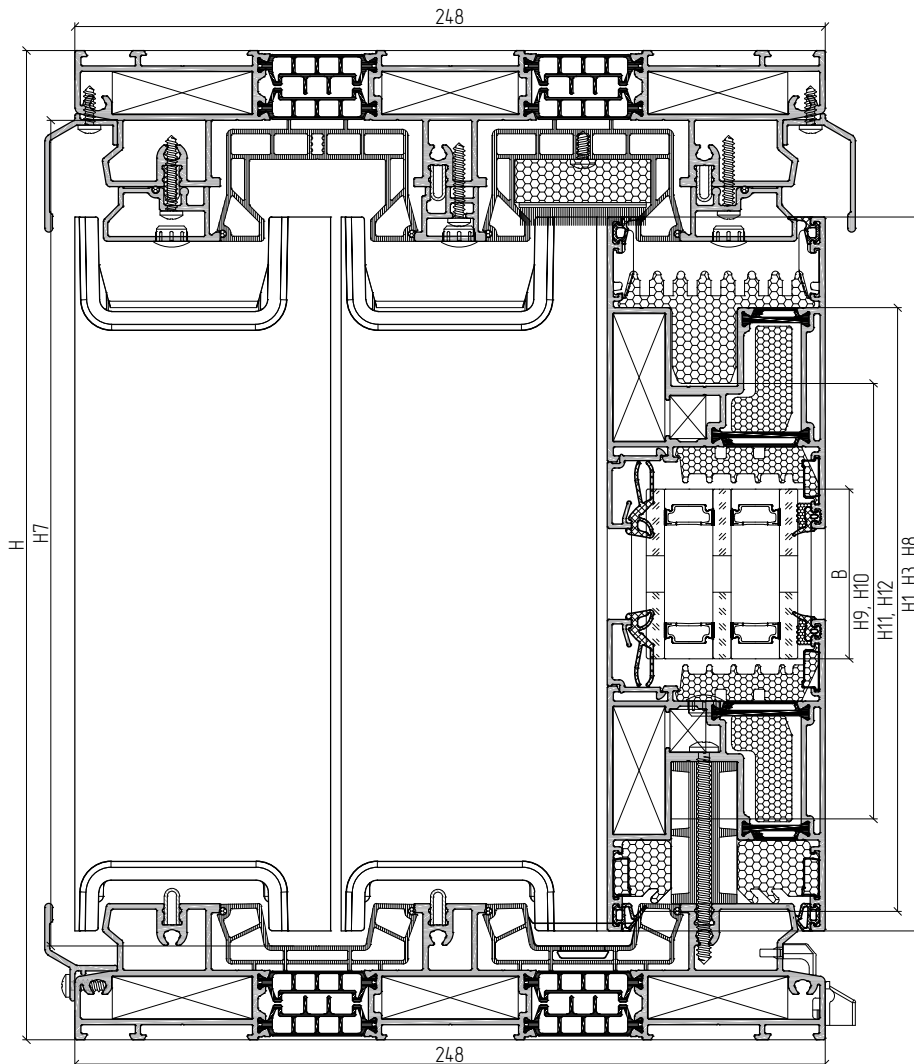





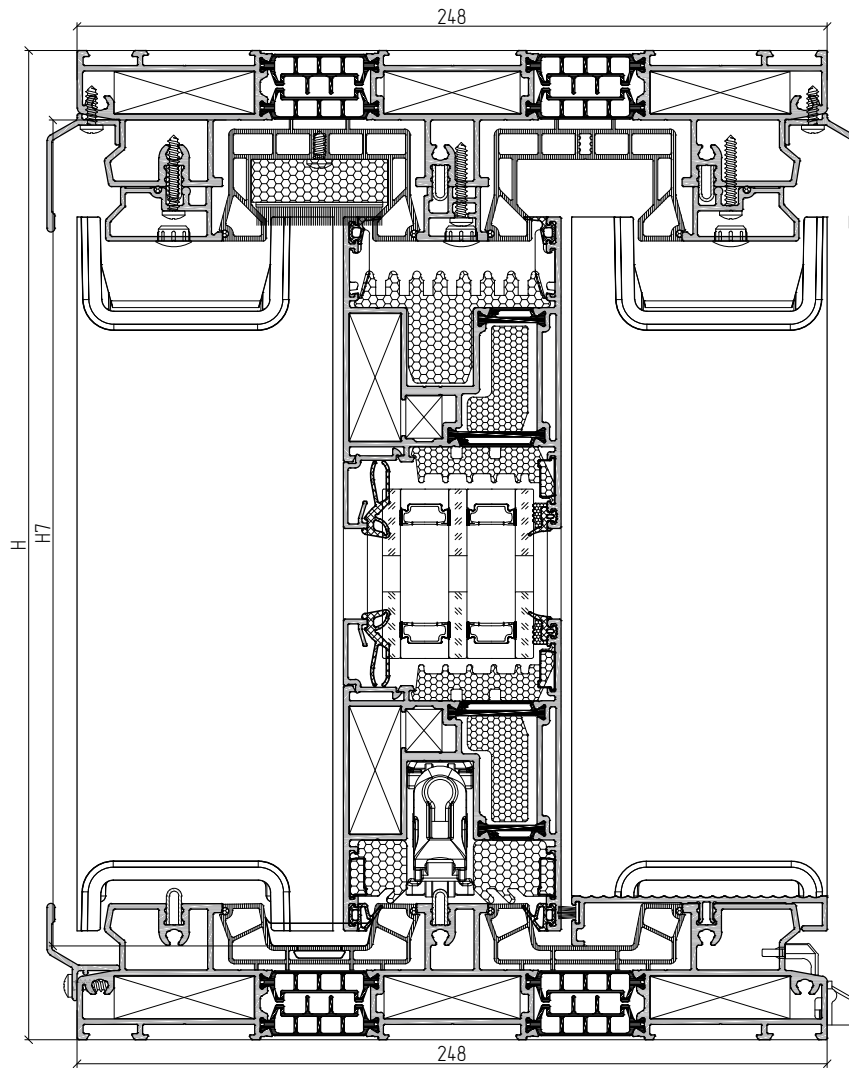

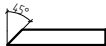
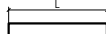
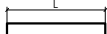
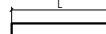
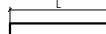
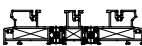





Vertical sections

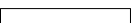

H1/L1 ≤ 25

Vertical sections



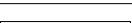





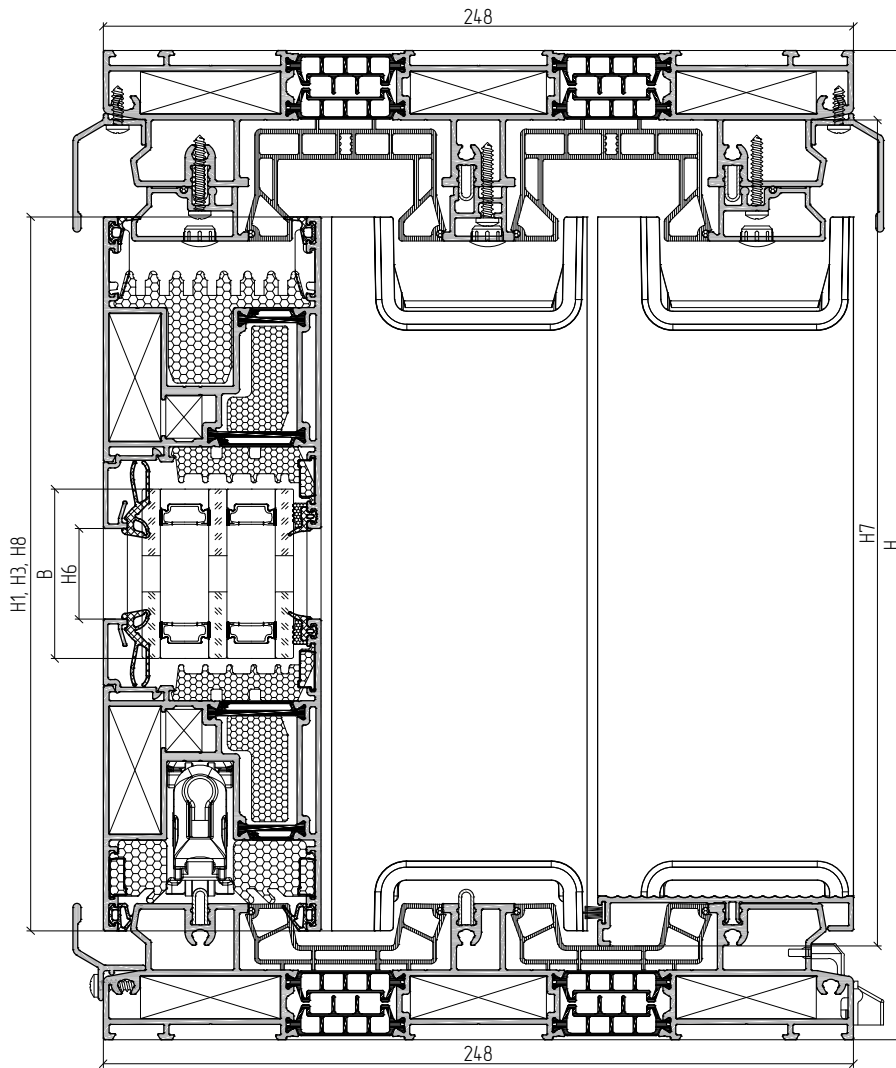

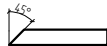
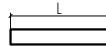
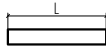
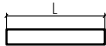
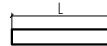
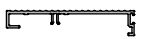
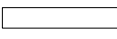

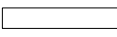

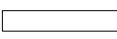
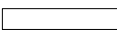
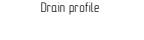
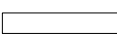
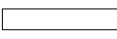

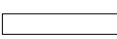
Article	Name Image		Type D5		Type D6		Type D7		Type D8	
				1..		1..		1..		1..
Profile										
AYPC.SL160.0104	Frame profile: Double track 		L	2	L	2	L	2	L	2
			H	2	H	2	H	2	H	2
AYPC.SL160.0202	Sash profile 		$L1=(L+284)/6$	12	$L1=(L+284)/6$	12	$L1=(L+284)/6$	12	$L1=(L+284)/6$	12
			H1-H-91	12	H1-H-91	12	H1-H-91	12	H1-H-91	12
AYPC.SL160.0504	Interlocking profile 		H2=H1	1	H2=H1	1	H2=H1	1	H2=H1	1
AYPC.SL160.0801	Guide rail (top) 		L2=L-90	2	L2=L-90	2	L2=L-90	2	L2=L-90	2
AYPC.SL160.0802	End profile 		H3=H1	8	H3=H1	8	H3=H1	8	H3=H1	8
AYPC.SL160.0804	Drain profile 		L3=L	2	L3=L	2	L3=L	2	L3=L	2
AYPC.SL160.0805	Drain profile 		L4=L	1	L4=L	1	L4=L	1	L4=L	1
AYPC.SL160.0810	Threshold profile: Double/triple track 		$L5=2L/3-194$	1	-	-	-	-	-	-
			-	-	H4=H-68	4	-	-	H4=H-68	4

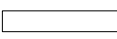
H1/L1 ≤ 25

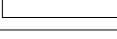
Vertical sections

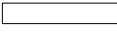







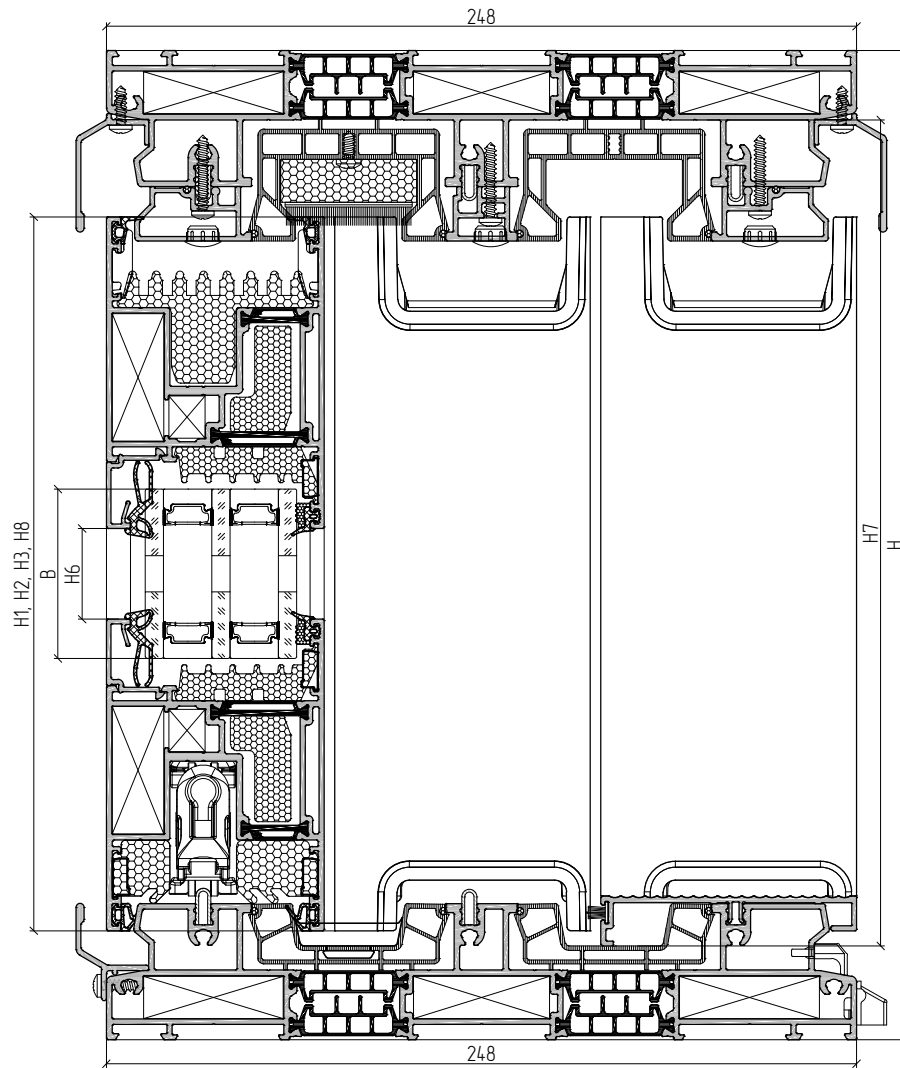

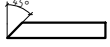
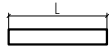
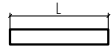
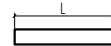
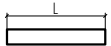

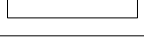
Article	Name Image		Type D5		Type D6		Type D7		Type D8	
				1..		1..		1..		1..
Profile										
AYPC.SL160.0811	Threshold profile: Double/triple track 		-	-	L6=2L/3-194	1	-	-	-	-
AYPC.SL160.0812	Guide rail (top) 		H5=H-68	4	-	-	H5=H-68	4	-	-
AYPC.C48.0602	Glass bead profile 		L7=L-90	1	L7=L-90	1	L7=L-90	1	L7=L-90	1
			L8=L1-162	12	L8=L1-162	12	L8=L1-162	12	L8=L1-162	12
AYPC.SL160.0920	Drain profile 		H6=H1-206	12	H6=H1-206	12	H6=H1-206	12	H6=H1-206	12
			* L9=L	2	* L9=L	2	* L9=L	2	* L9=L	2
AYPC.SL160.0921	Drain profile 		H7=H-54	4	H7=H-54	4	H7=H-54	4	H7=H-54	4
AYPC.SL160.0938	Interlock 		** L10=L	2	** L10=L	2	** L10=L	2	** L10=L	2
AYPC.SL160.1950	Stainless steel track 		H8=H1	8	H8=H1	8	H8=H1	8	H8=H1	8
			L11=L-95	2	L11=L-95	2	L11=L-95	3	L11=L-95	3
AYPC.SL160.0911	Foamed insert 		100	L/170	100	L/170	100	L/170	100	L/170
AYPC.SL160.0911	Foamed insert 		L12=L1-42	6	L12=L1-42	6	L12=L1-42	6	L12=L1-42	6

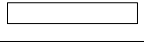
H1/L1 ≤ 25

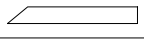
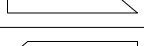
Vertical sections

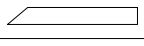

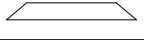
Article	Name Image		Type D5		Type D6		Type D7		Type D8	
				1...		1...		1...		1...
Profile										
AYPC.SL160.0912	Foamed insert 		H9-H1-92	6	H9-H1-92	6	H9-H1-92	6	H9-H1-92	6
PE21x26	Thermal insert 		H10-H1-92	6	H10-H1-92	6	H10-H1-92	6	H10-H1-92	6
AYPC.SL160.0960	Thermal insert 		L13-L1-36	6	L13-L1-36	6	L13-L1-36	6	L13-L1-36	6
			H11-H1-36	6	H11-H1-36	6	H11-H1-36	6	H11-H1-36	6
AYPC.SL160.0961	Thermal insert 		L14-L1-36	6	L14-L1-36	6	L14-L1-36	6	L14-L1-36	6
			H12-H1-36	6	H12-H1-36	6	H12-H1-36	6	H12-H1-36	6
AYPC.W72.0911	Rebate insulation 		L15=(A+B)x2-6x100	6	L15=(A+B)x2-6x100	6	L15=(A+B)x2-6x100	6	L15=(A+B)x2-6x100	6

H1/L1 ≤ 25

Vertical sections

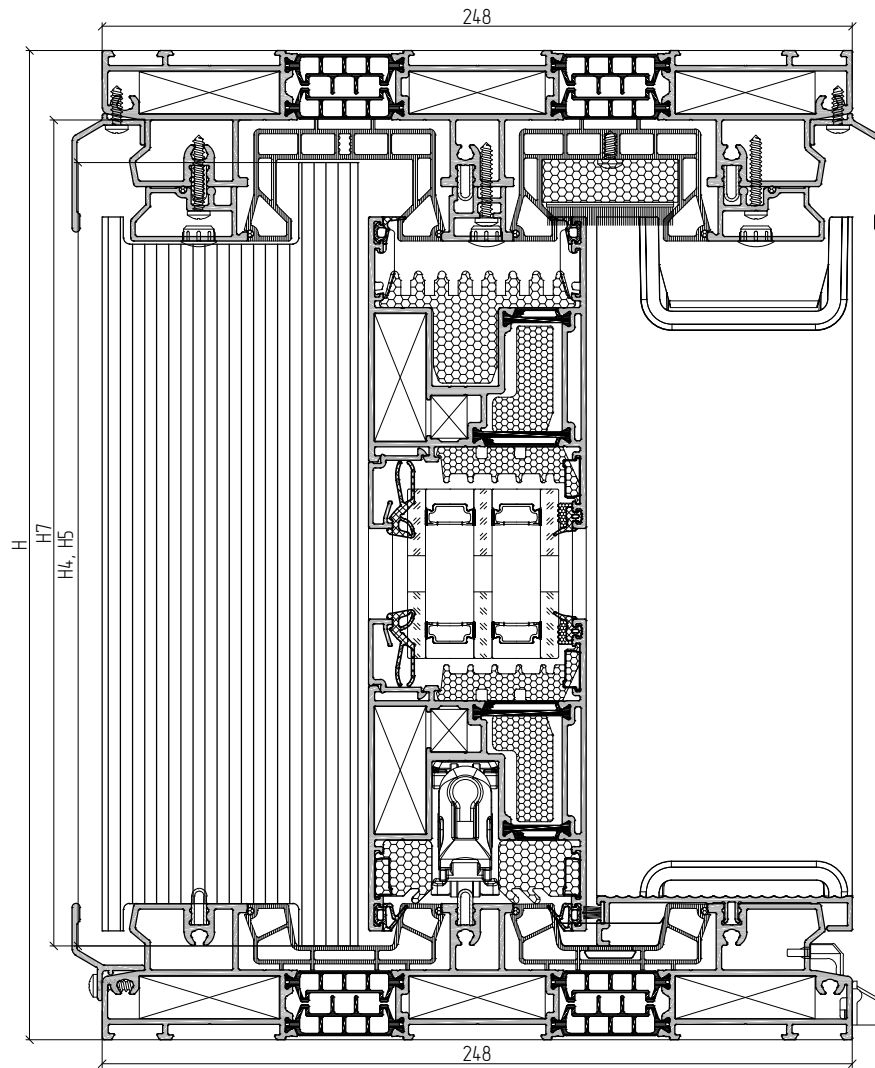







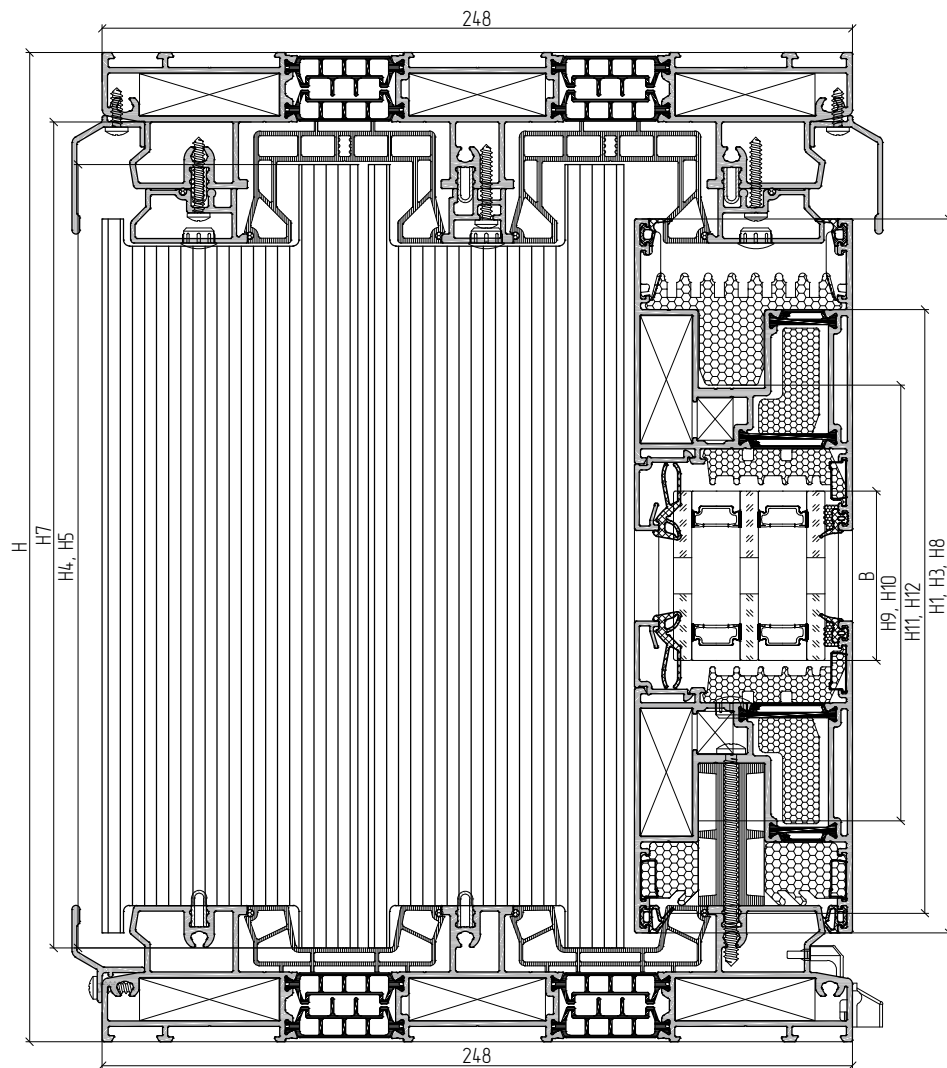



Article	Name Image	1..			
		Type D5	Type D6	Type D7	Type D8
Accessories					
AYPC.SL160.0940	Ledge kit 	8	8	8	8
AYPC.SL160.0941	Sealing block 	4	4	4	4
AYPC.SL160.0950	Corner cleat 	24	24	24	24
AYPC.SL160.0950-01	Corner cleat 	8	8	8	8
AYPC.SL160.0950-03	Corner cleat 	4	4	4	4
AYPC.SL160.0951-01	Corner cleat 	24	24	24	24
AYPC.W50.1901	Corner cleat 	72	72	72	72
AYPC.SL160.0905	Fixator 	8	8	-	-
AYPC.SL160.0928	Decorative plug 	H2/450+L2/250+ L7/500+H8/40+8	H2/450+L2/250+ L7/500+H8/40+8	H2/450+L2/250+ L7/500+H8/40	H2/450+L2/250+ L7/500+H8/40

H1/L1 ≤ 25

Vertical sections



Article	Name	Image	1..			
			Type D5	Type D6	Type D7	Type D8
Accessories						
AYPC.SL160.0933	Interlock plug		2	2	2	2
AYPC.SL160.0943	Encapsulating insert		2	2	2	2
AYPC.SL160.0944	Encapsulating insert		2	2	2	2
AYPC.SL160.0945	Encapsulating insert		2	2	2	2
AYPC.SL160.0946	Encapsulating insert		6	6	6	6
AYPC.SL160.0949	Bearing support		36	36	36	36
100x56x1(3)	Leveling support		36(36)	36(36)	36(36)	36(36)
AYPC.SL160.0929	Water drain plug		L/500	L/500	L/500	L/500
AYPC.C48.0919M-01	Water drain plug		2	2	2	2
FRK177	Rubber corner		24	24	24	24
FRK178	Rubber corner		12	12	12	12

H1/L1 < 25

Horizontal sections

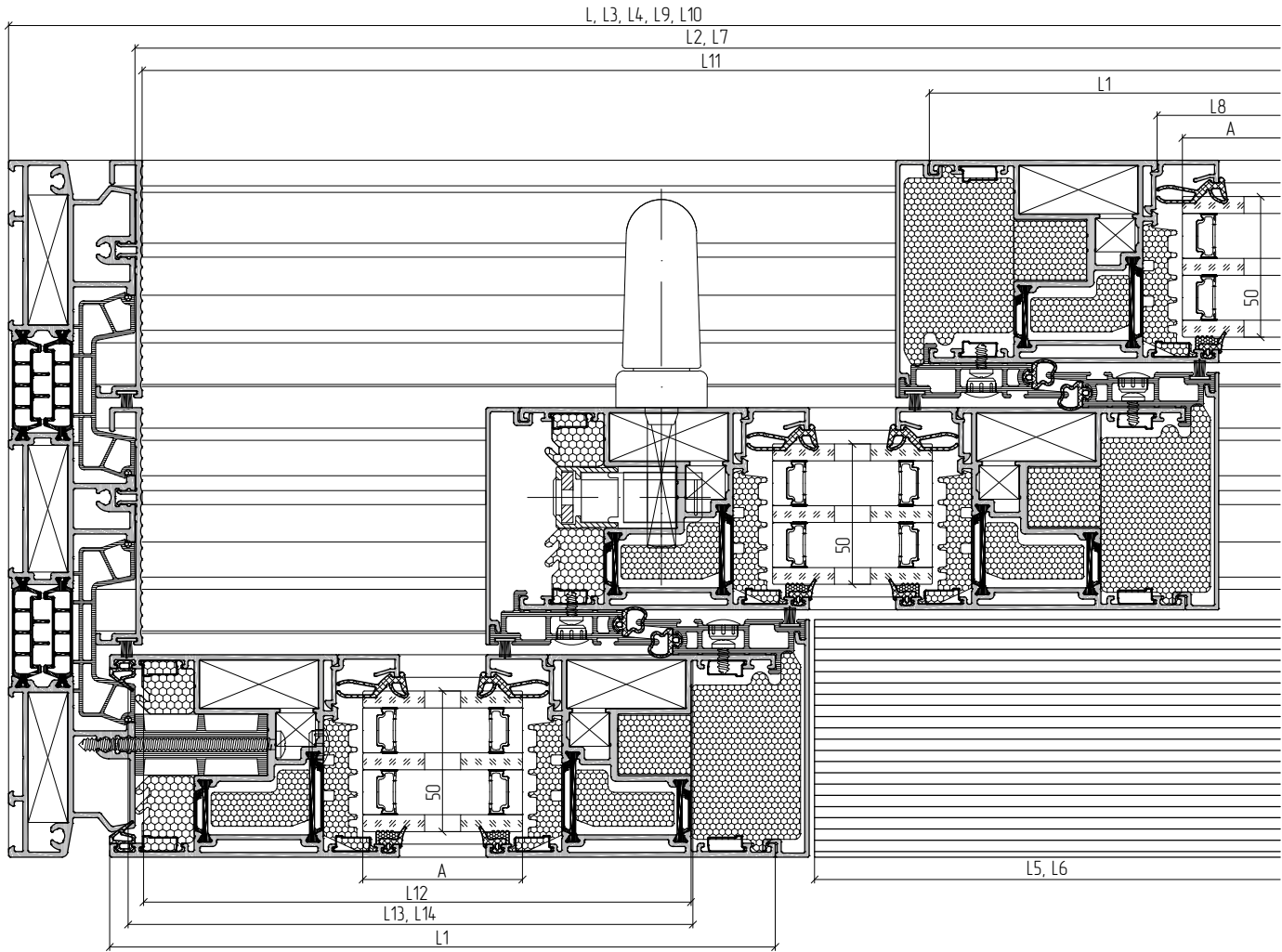

Article	Name	Image	1..			
			Type D5	Type D6	Type D7	Type D8
Accessories						
FRK178-01	Rubber corner		12	12	12	12
FRK179	Rubber corner		24	24	24	24
Hardware						
3.9x13-A2 DIN7981	Self-tapping screw		L3/100	L3/100	L3/100	L3/100
3.9x13-A2 DIN7982	Self-tapping screw		72	72	72	72
3.9x25-A2 DIN7981	Self-tapping screw		L2/150	L2/150	L2/150	L2/150
4.2x9.5-A2 DIN7981	Self-tapping screw		H8/40	H8/40	H8/40	H8/40
4.8x32-A2 DIN7981	Self-tapping screw		16	16	-	-
4.8x70-A2 DIN7981	Self-tapping screw		H2/450+8	H2/450+8	H2/450	H2/450
5x10 DIN6325D	Pin		48	48	48	48

H1/L1 ≤ 25

Horizontal sections

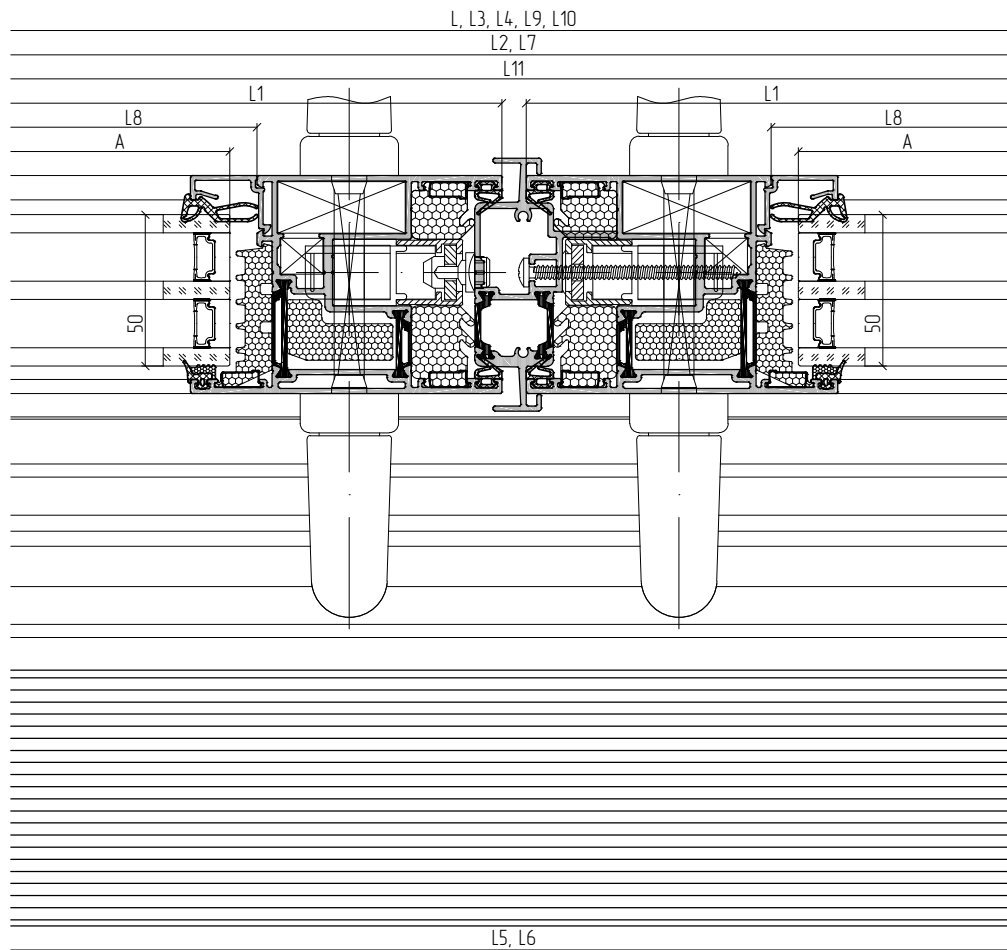

Article	Name	Image	Type D5		Type D6		Type D7		Type D8	
				1..		1..		1..		1..
Gaskets										
FRK50	Gasket		H8	8	H8	8	H8	8	H8	8
FRK175	Rebate gasket		L1x3+H1x2	4	L1x3+H1x2	4	L1x3+H1x2	4	L1x3+H1x2	4
FRK176	Gasket		L1x2	6	L1x2	6	L1x2	6	L1x2	6
FRK188	Gasket		-	-	-	-	H1	2	H1	2
FRK193	Wedge gasket		(A+B)x2	6	(A+B)x2	6	(A+B)x2	6	(A+B)x2	6
FRK197	Outside gasket		(A+B)x2	6	(A+B)x2	6	(A+B)x2	6	(A+B)x2	6
AYPC.SL160.0948	Sealing cord		L2x2+H7x8+L9x4+L10x4	1	L2x2+H7x8+L9x4+L10x4	1	L2x2+H7x8+L9x4+L10x4	1	L2x2+H7x8+L9x4+L10x4	1
ISE01	Felt sealing		L5+H5x4+H8x8	1	H4x4+L6+H8x8	1	H5x4+H8x8	1	H4x4+H8x8	1

$H1/L1 \leq 25$

Horizontal sections

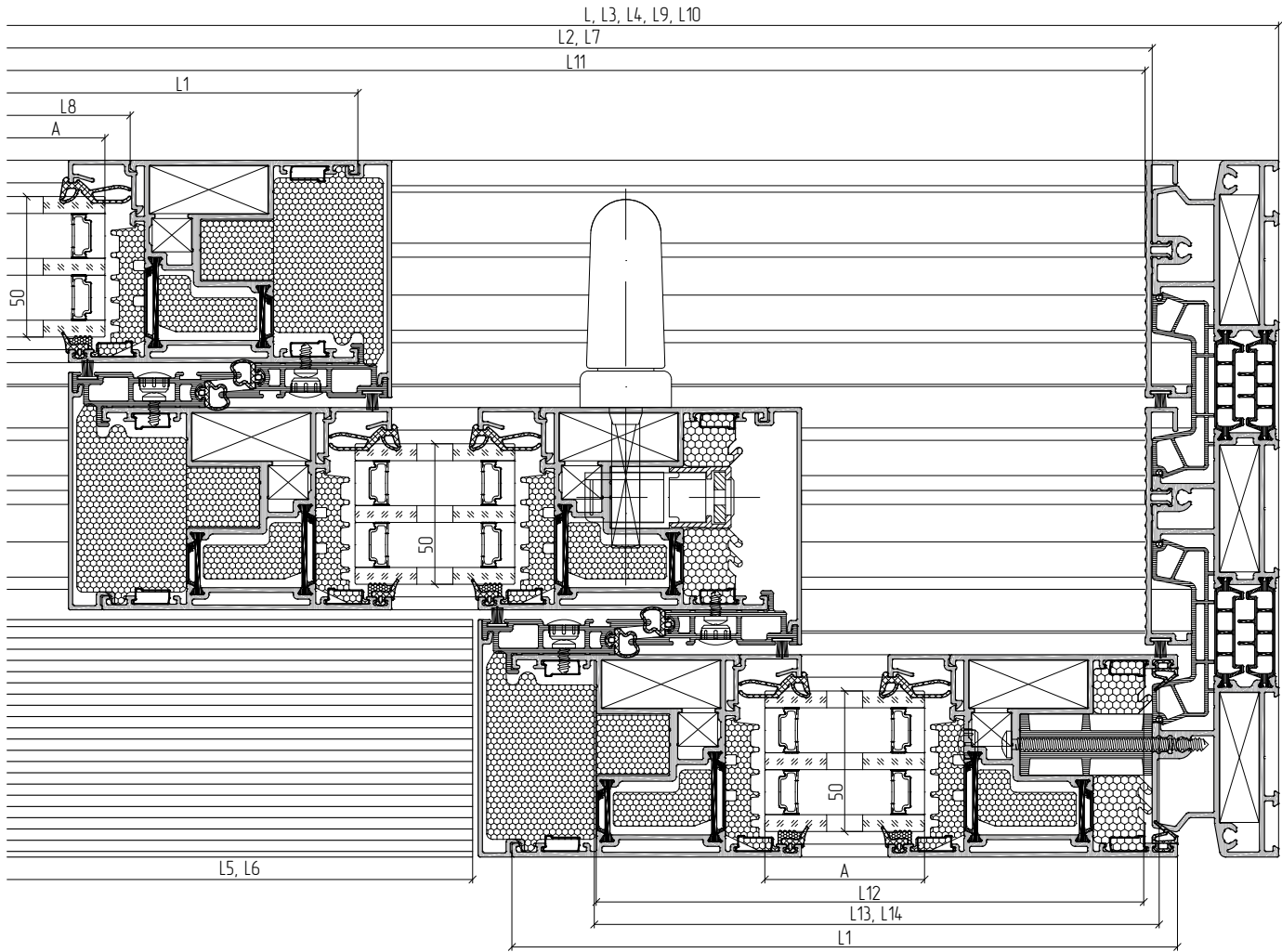

Infill							
Type D5		Type D6		Type D7		Type D8	
A=L1-180; B=H1-180	6	A=L1-180; B=H1-180	6	A=L1-180; B=H1-180	6	A=L1-180; B=H1-180	6



1. When manufacturing C2 type door with the width $L > 6500$ mm it is necessary to install additional connector and encapsulating inserts (see page 08.53).
 2. Select glass bead profile and rubber gaskets according to the infill thickness (see the section 05 - Glazing table).
- * length of AYP.C.SL160.0922 profile is given for calculation of quantity. See dimensions and cutting on page 08.29.
 ** length of AYP.C.SL160.0923 profile is given for calculation of quantity. See dimensions and cutting on page 08.11.



ALUTECH ALT SL160

Lifting and sliding constructions

PROFILE MACHINING AND ASSEMBLAGE

01

02

03

04

05

06

07

08

09

10

Table of symbols

LEF – external frame width;
LIF – internal frame width;
HEF – external frame height;
HIF – internal frame height

LG – glass width;
HG – glass height.

LES – external sash width;
LIS – internal sash width;
LS – sash width;
HES – external sash height;
HIS – internal sash height;
HS – sash height;

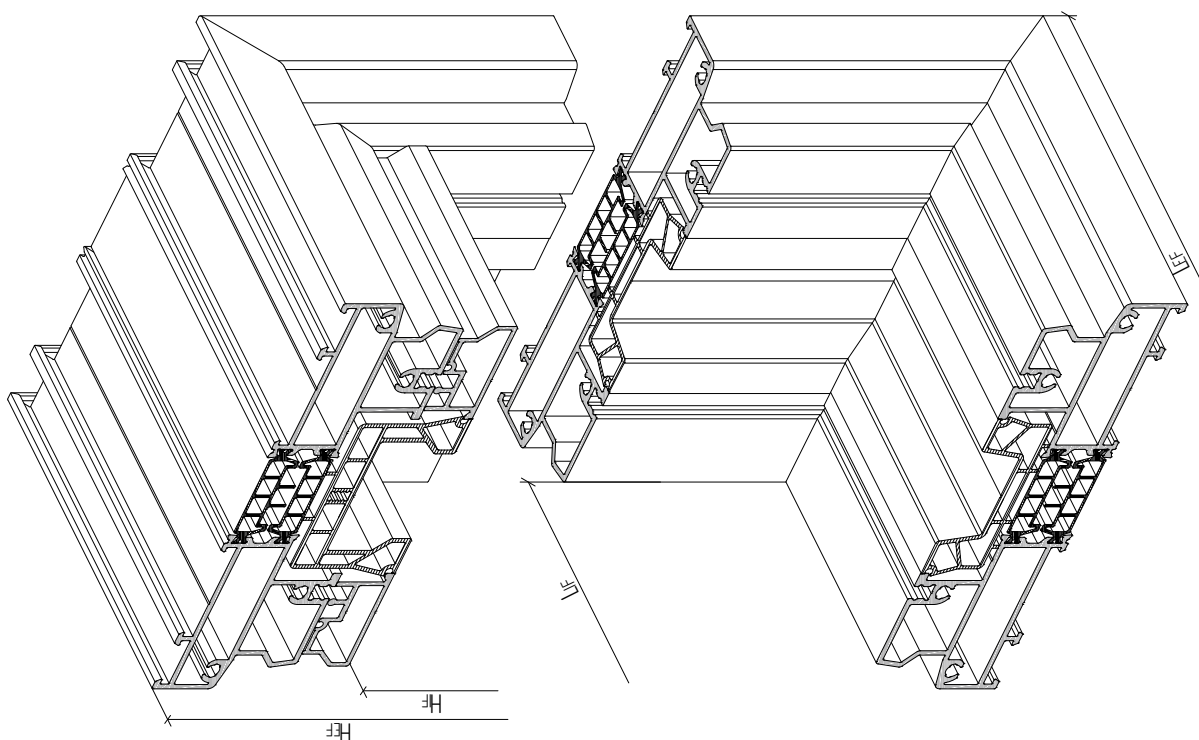
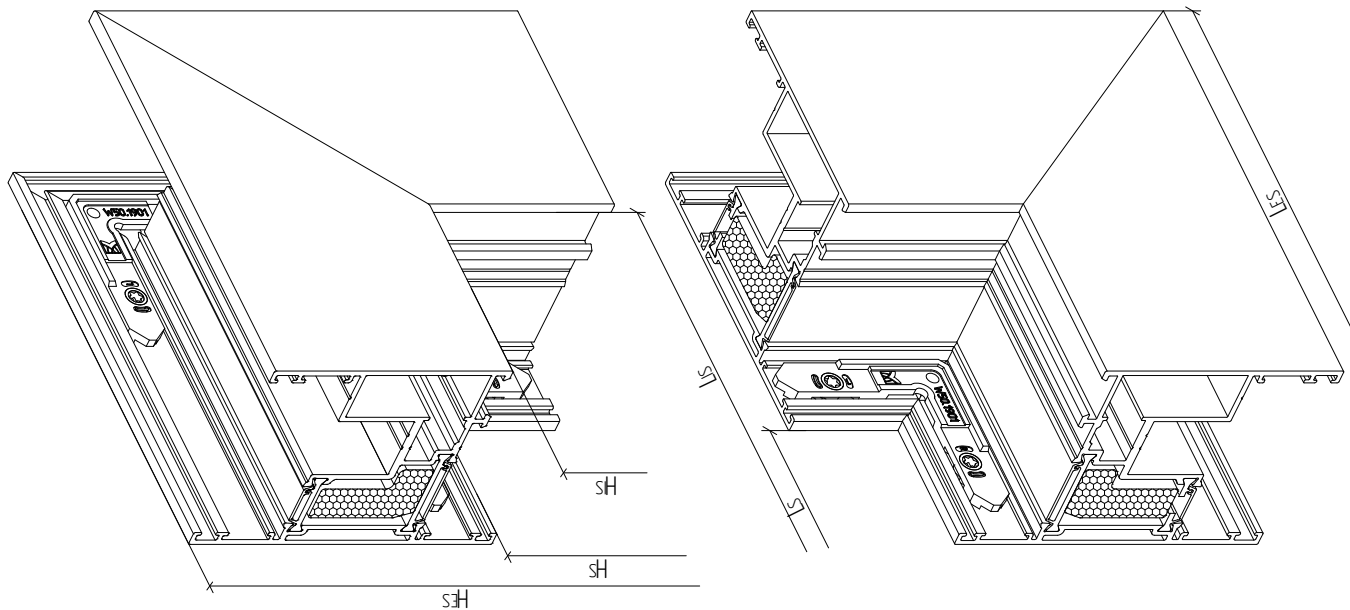

Corner connection of AYPC.SL160.0102 /
AYPC.SL160.0103 sash profiles

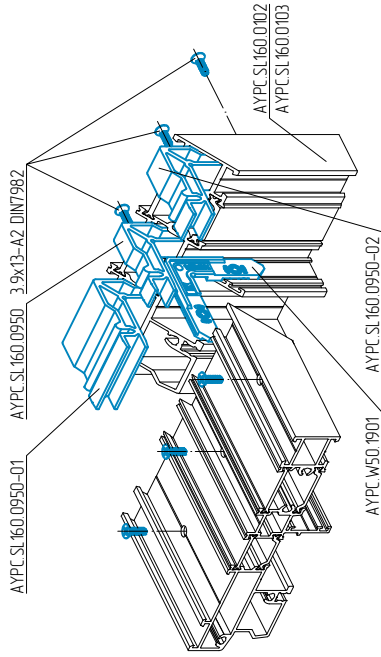

Corner connection of AYPC.SL160.0202 sash
profiles

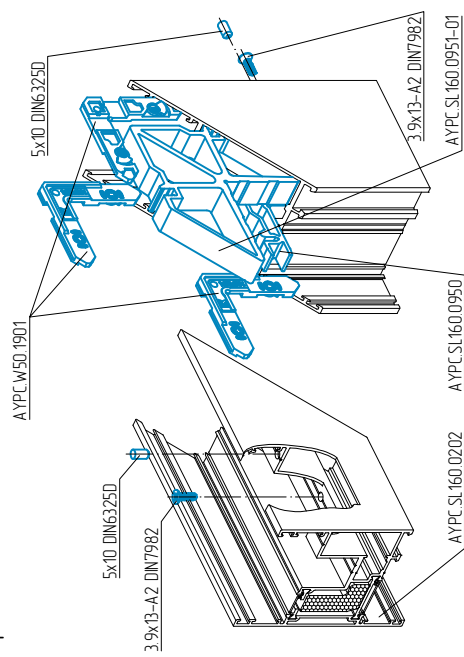

Giesse 00336 Corner cleat

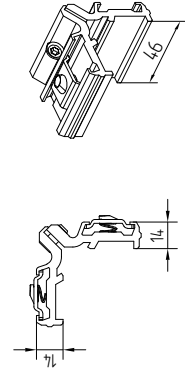

Corner connection of AYPC.SL160.0101 frame profiles

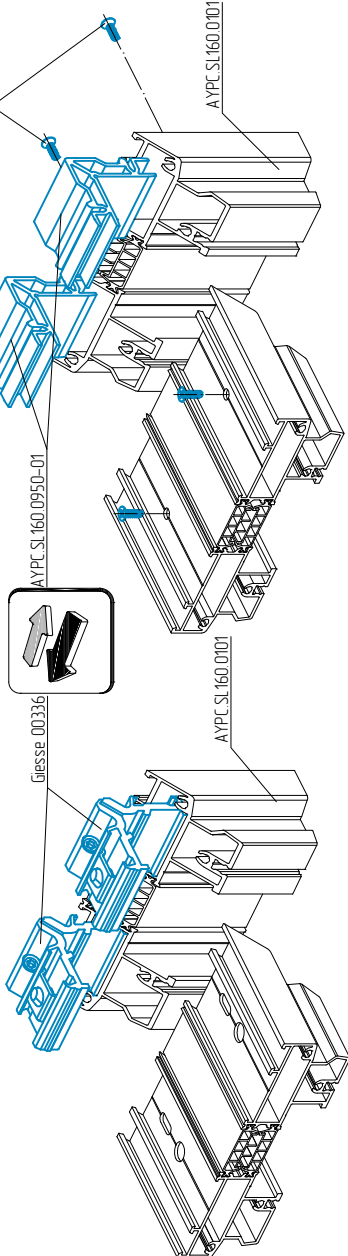

Corner connection of AYPC.SL160.0104 frame profiles

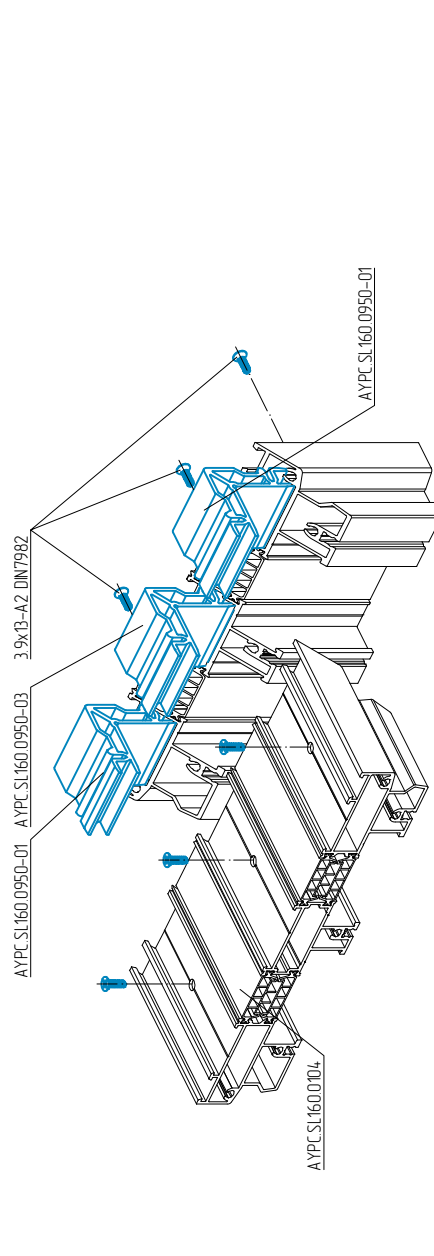

Corner cleat from AYPC.C4.8.0705 profile
Corner cleat from AYPC.GS106.0701 profile

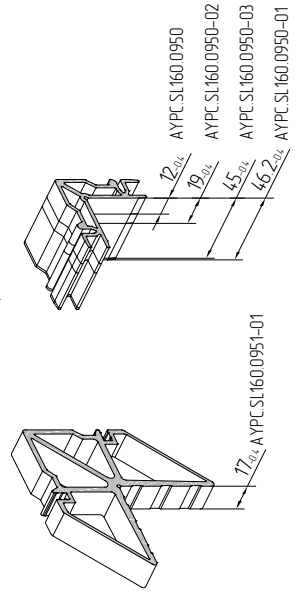

Profiles for corner cleat

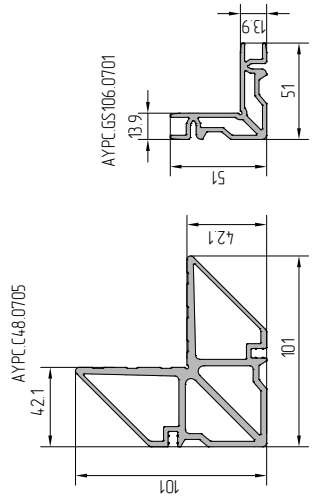

Frame profile machining for corner connection using Giesse 00336 corner cleat

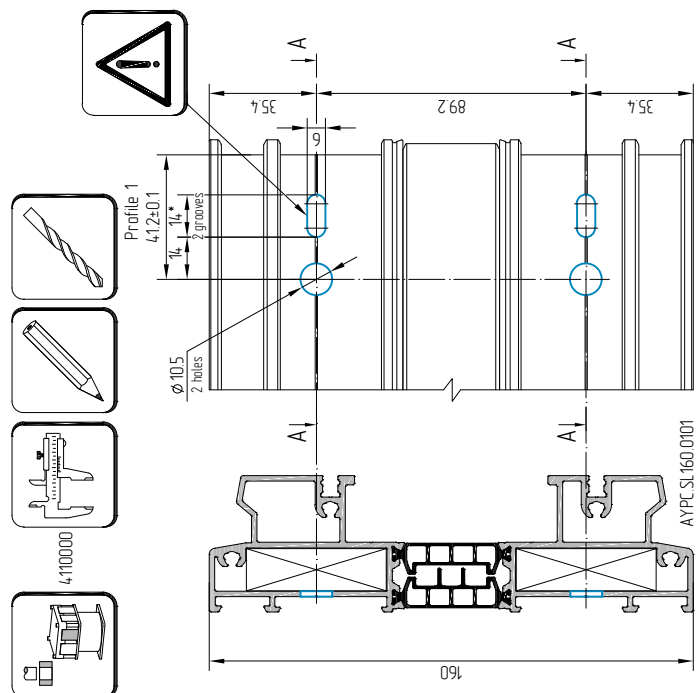

* - Drill from one side of the corner only (see Profile 1 machining) - for tension screw access

Frame profile machining for corner connection using self-tapping screws

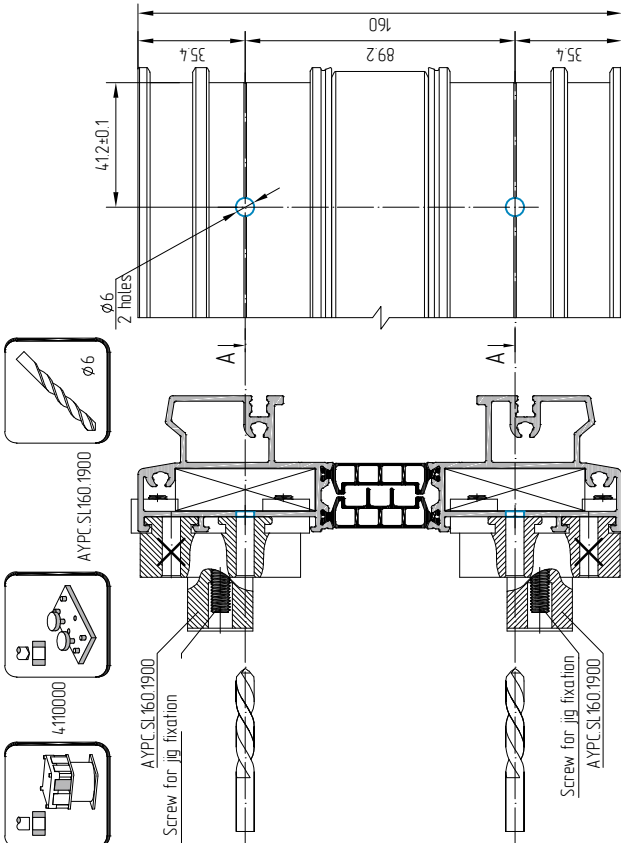

A-A

A-A

A-A

A-A

A-A

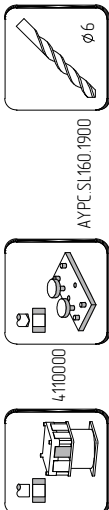
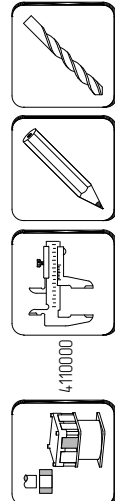

4110000

4110000

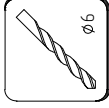
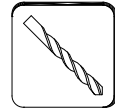
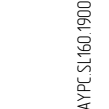
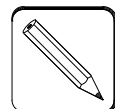
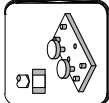
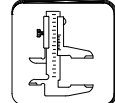

Frame profile machining for corner connection using self-tapping screws

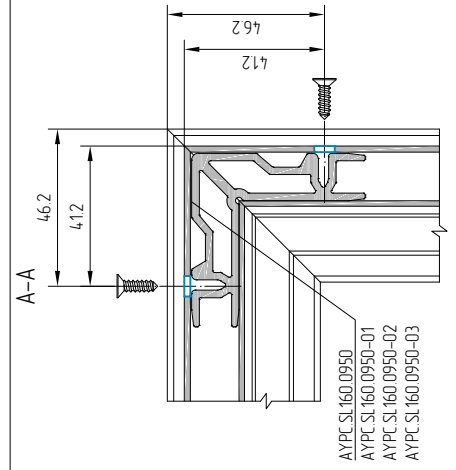
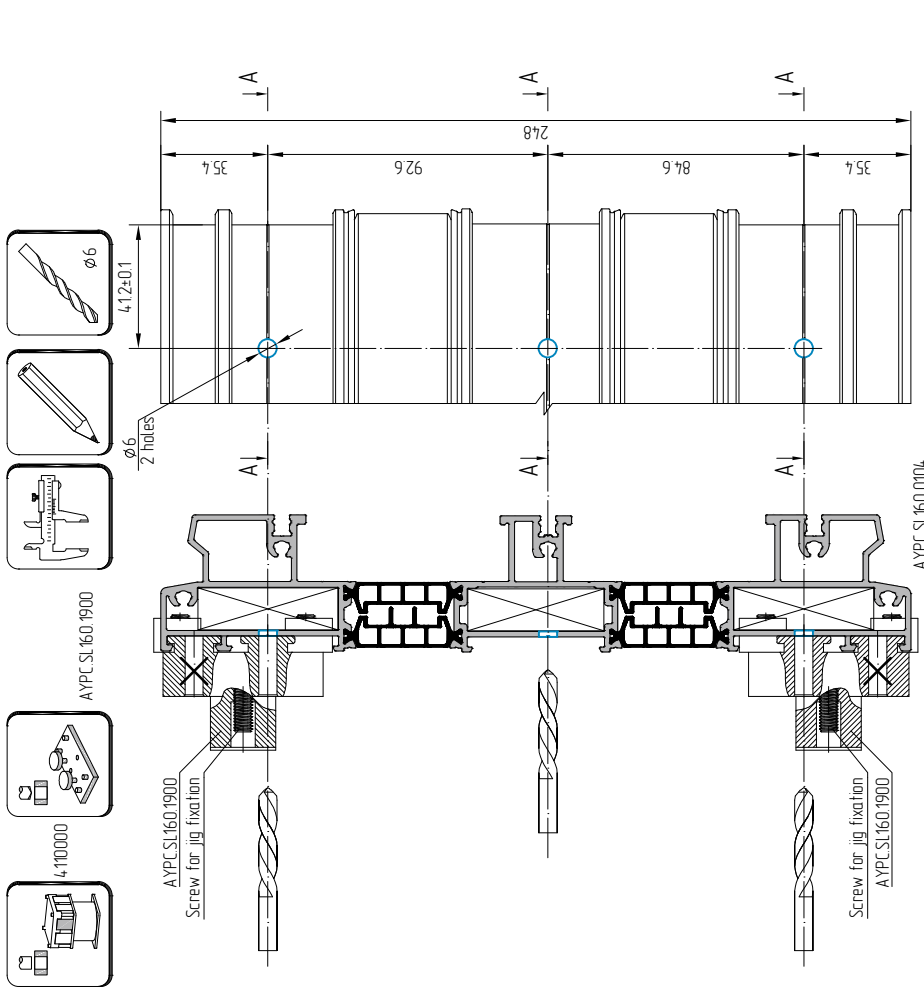
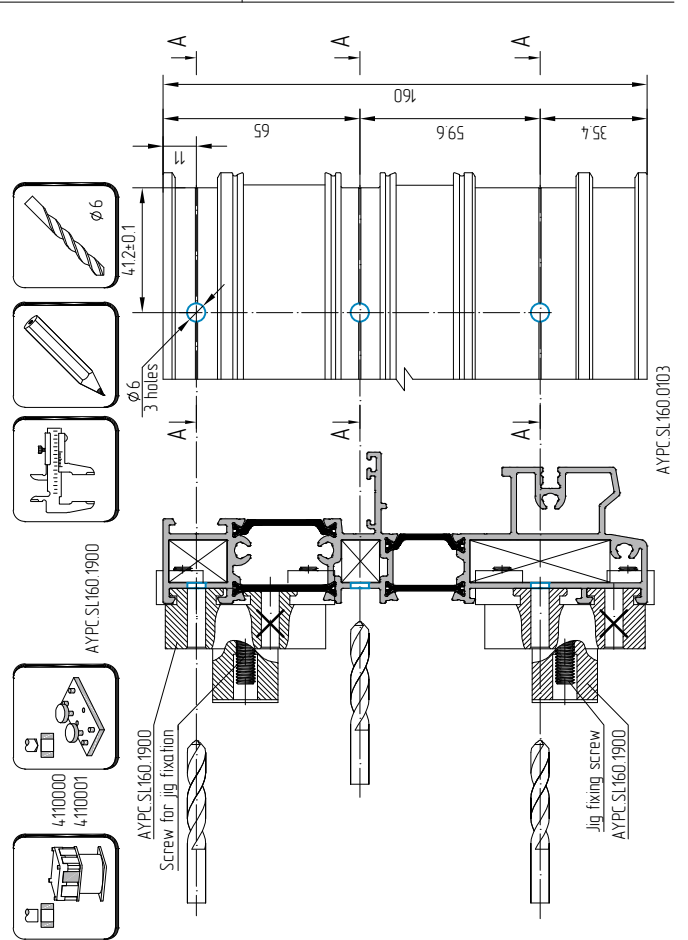
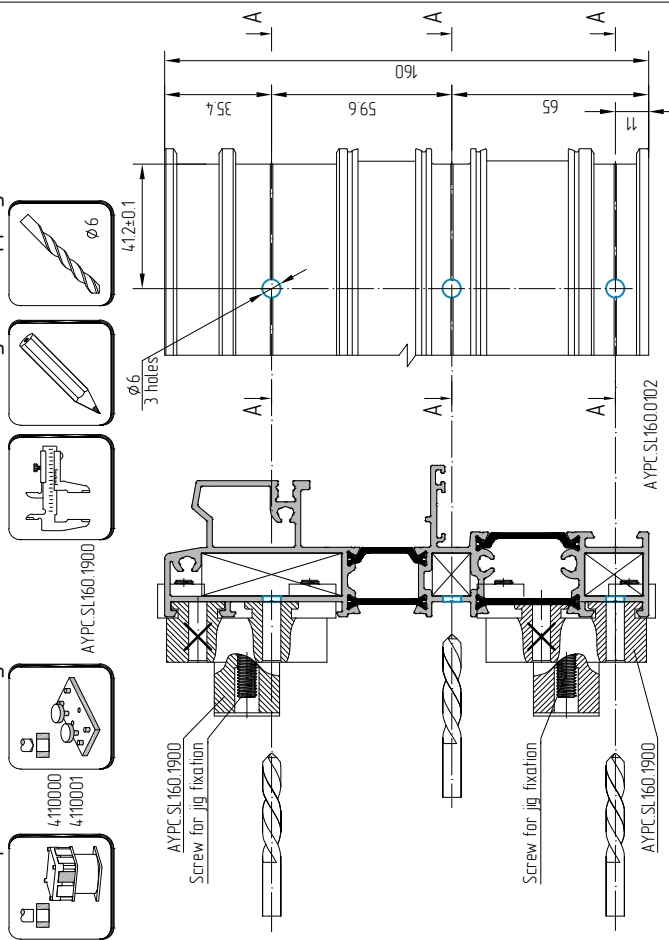

Corner crimping of frame profiles

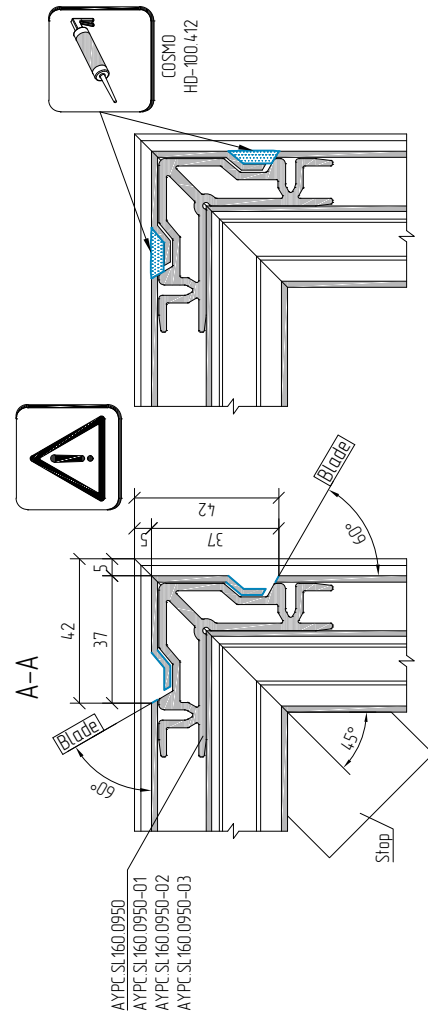
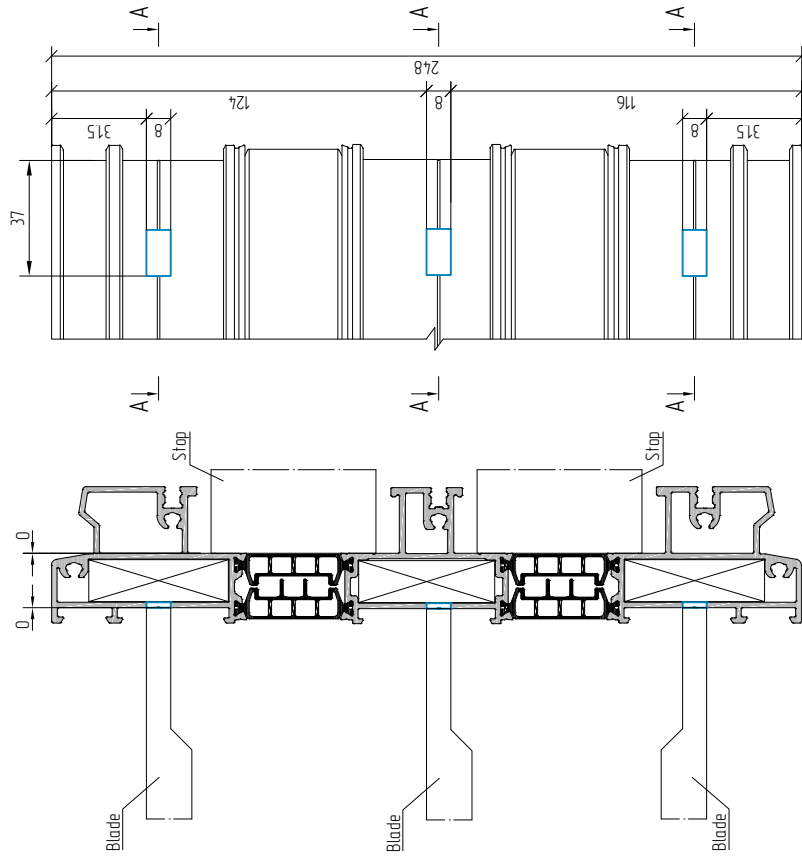
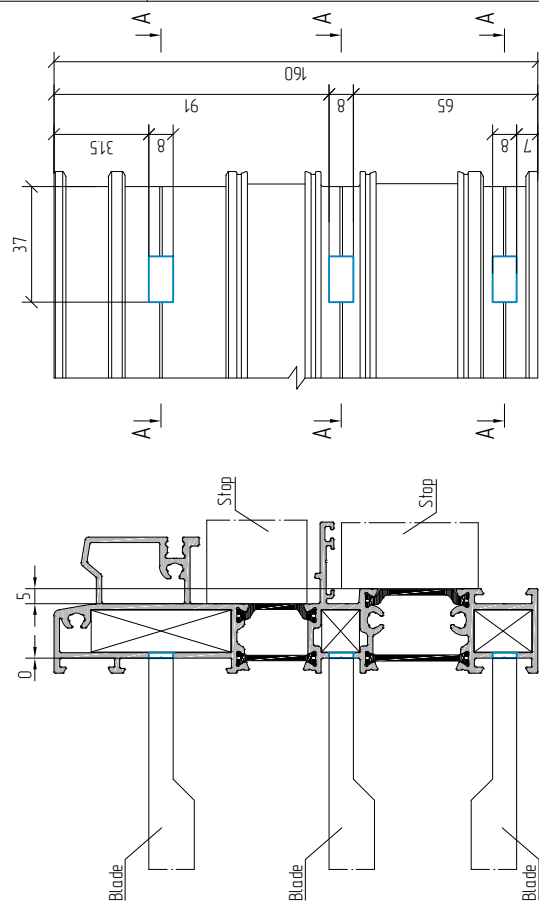
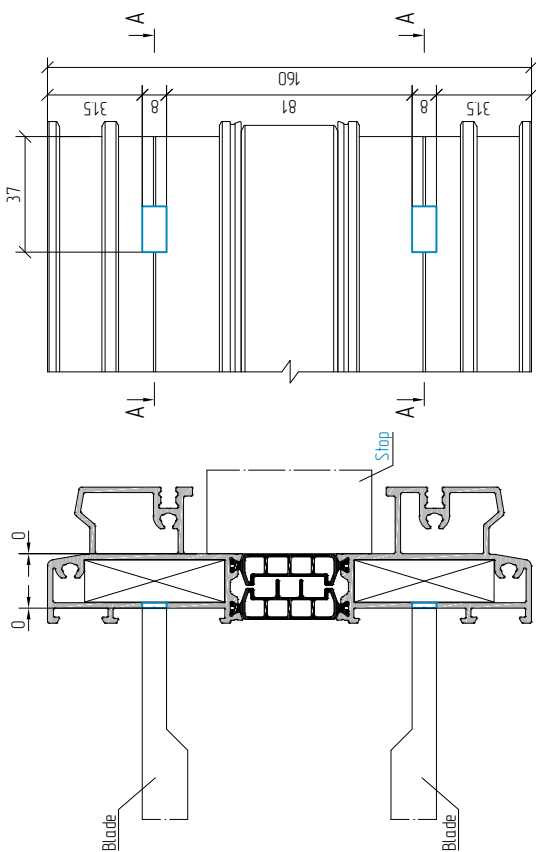

The stop is shown schematically and depends on the equipment used

Machining of sash profiles for corner connection using self-tapping screws

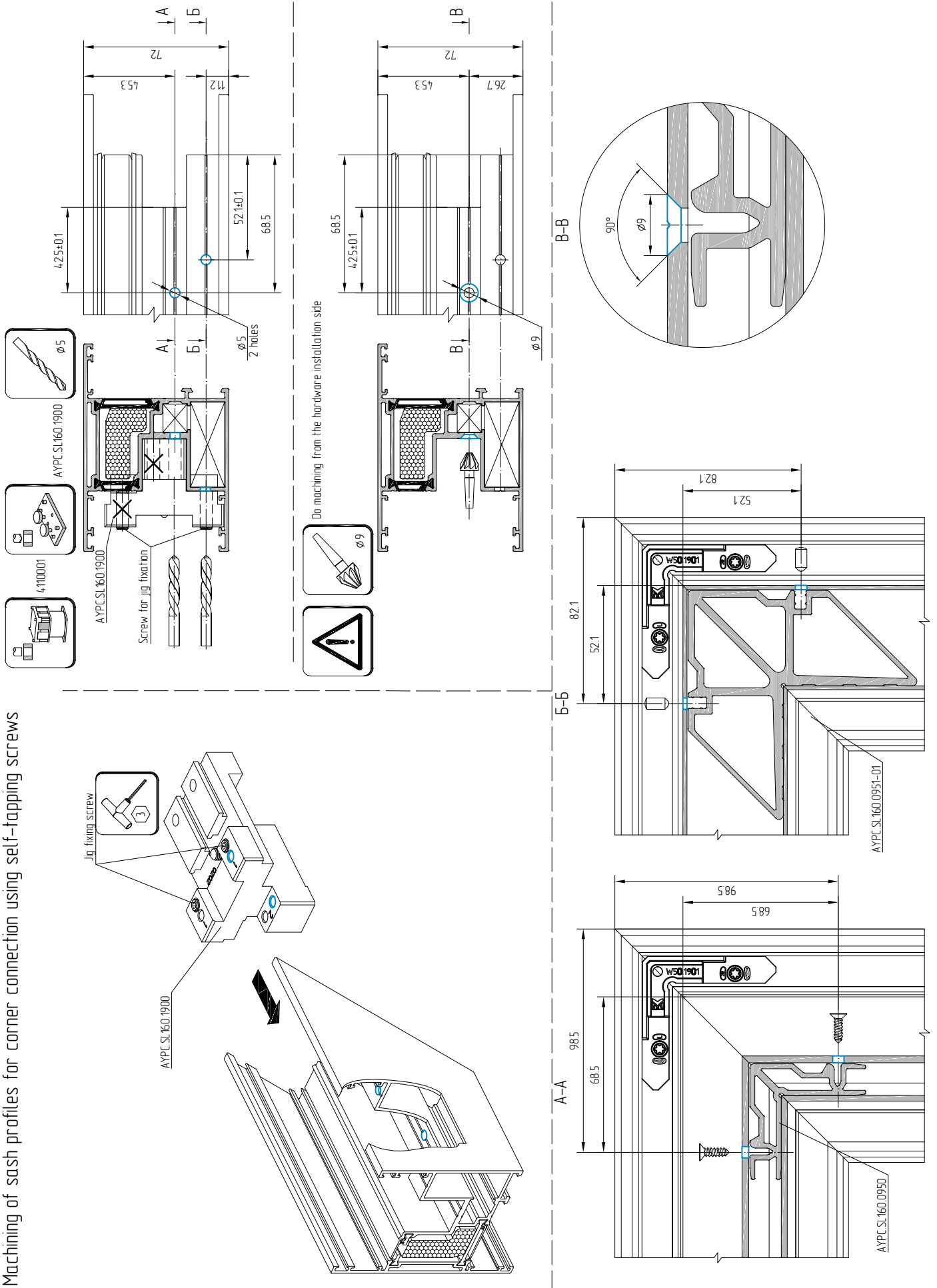

Corner crimping of sash profile



Verify the crimping machine capability before machining. If crimping is impossible, use self-tapping screw

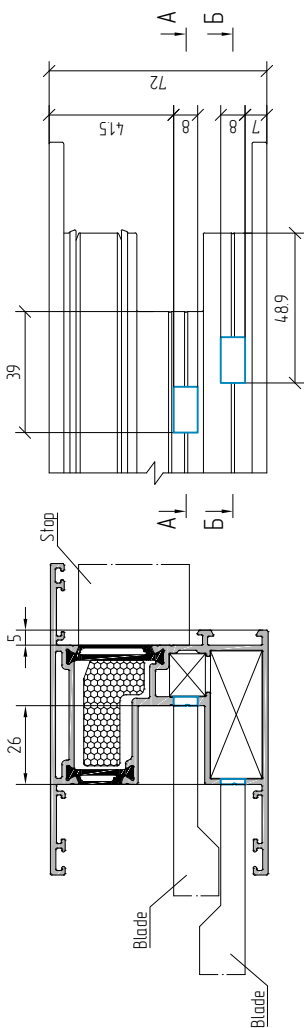

A-A

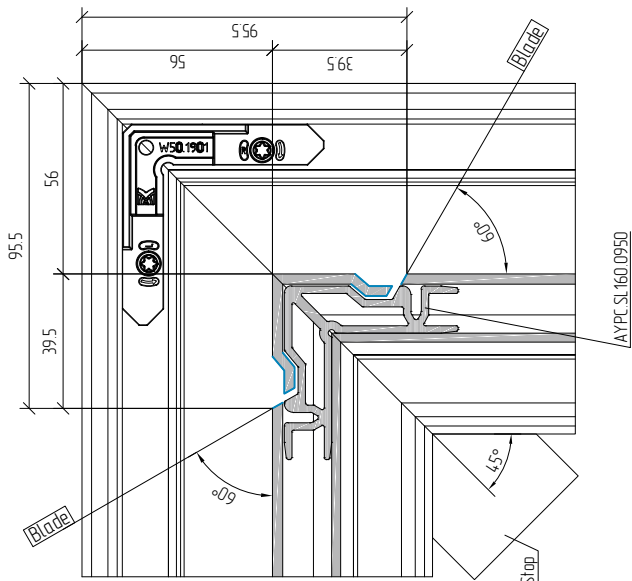

B-B

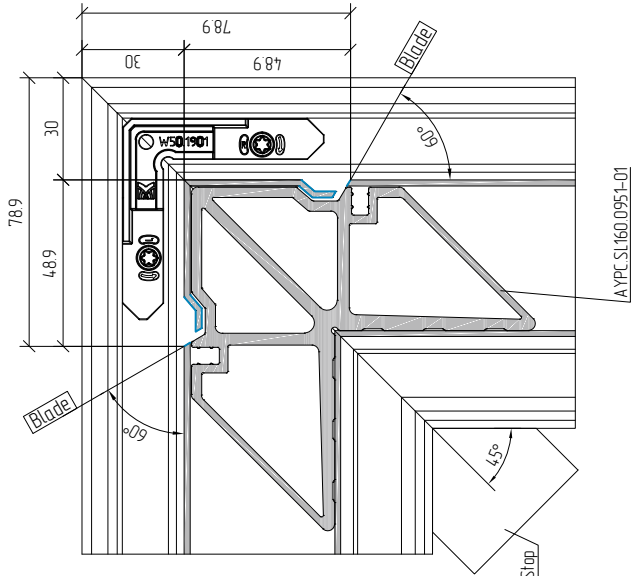

The stop is shown schematically and depends on the equipment used

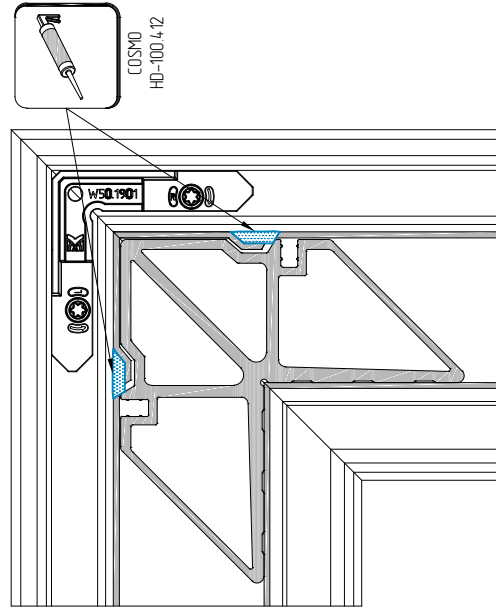
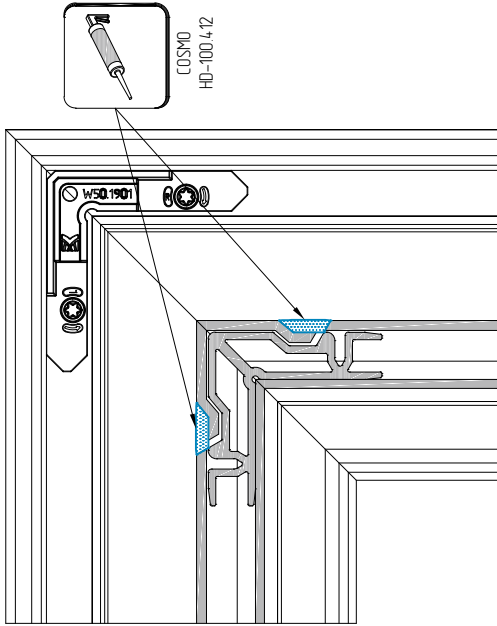

Machining of AYPC.SL160.0923 drain profiles. Drainage system

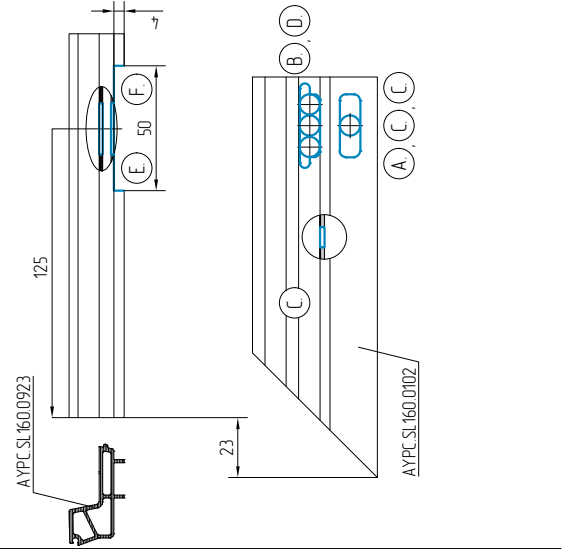
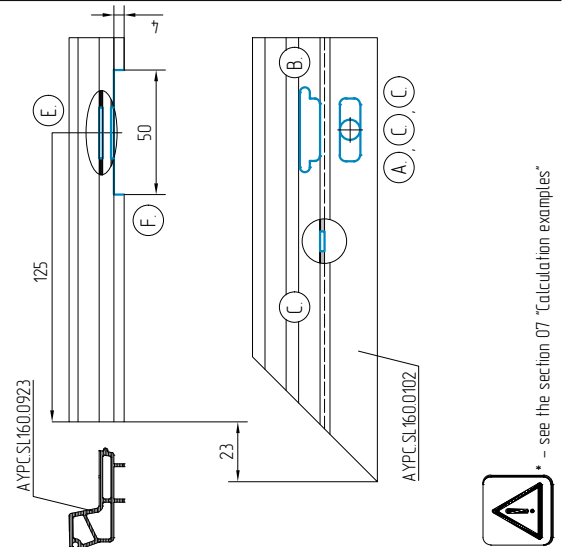
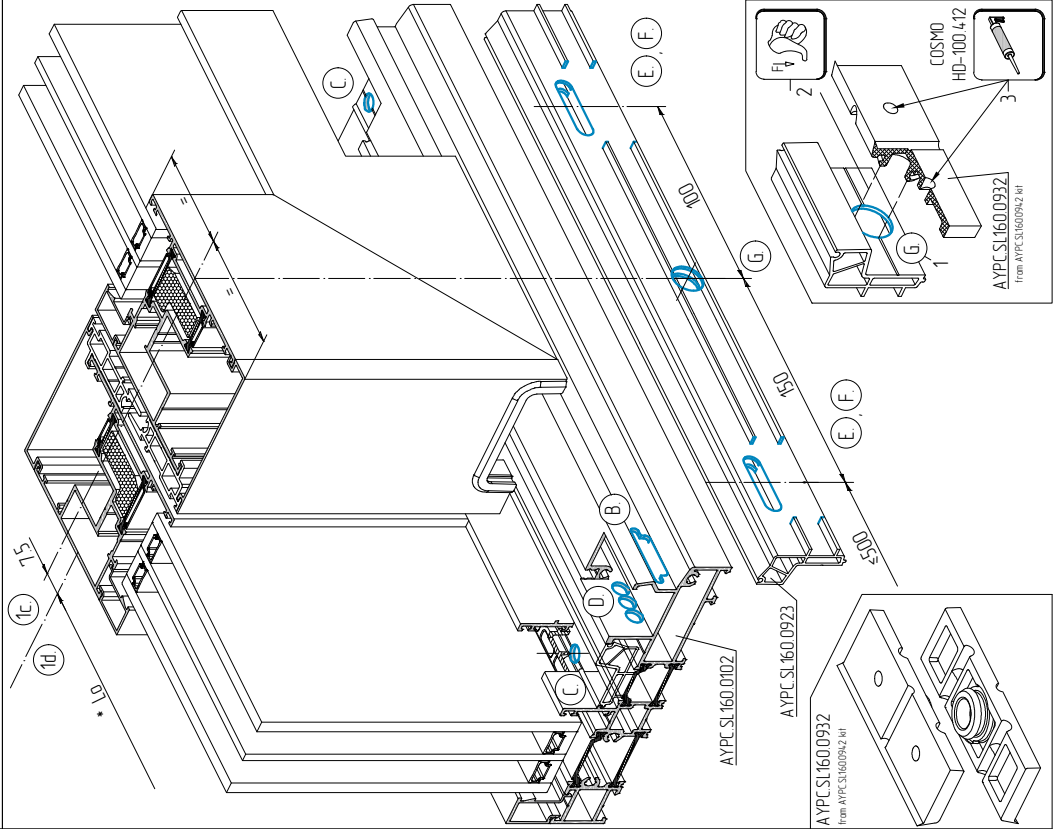
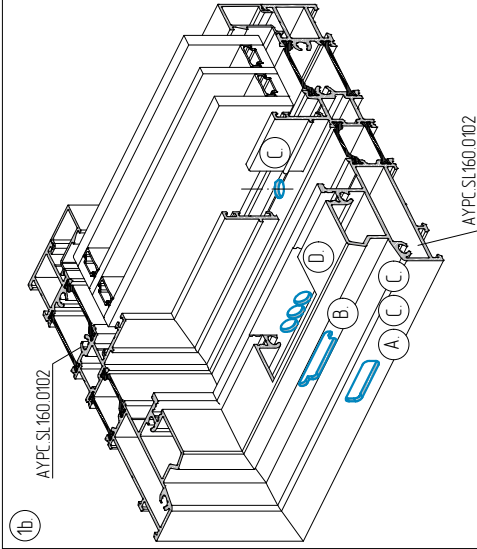
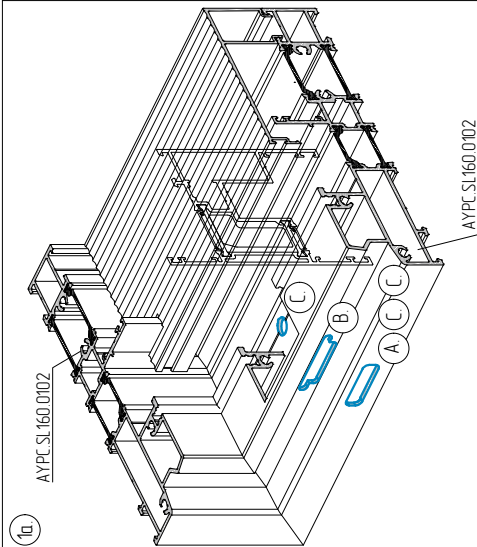
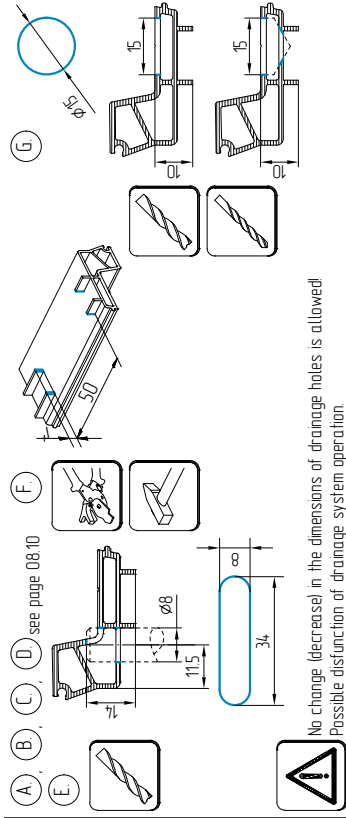
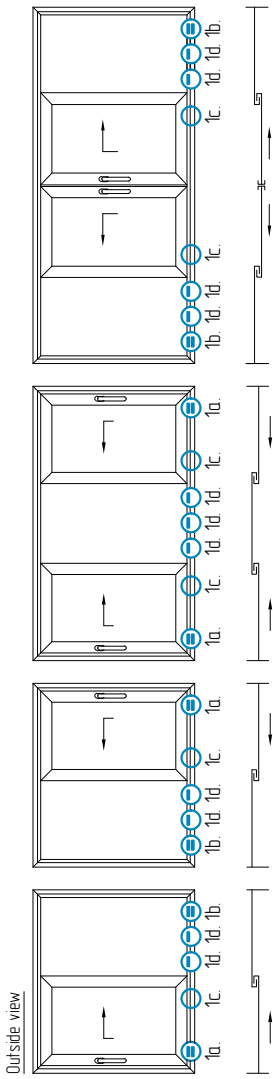

* - see the section 07 "Calculation examples"

Machining of AYPC.SI.160.0103 frame profiles. Drainage system

Outside view

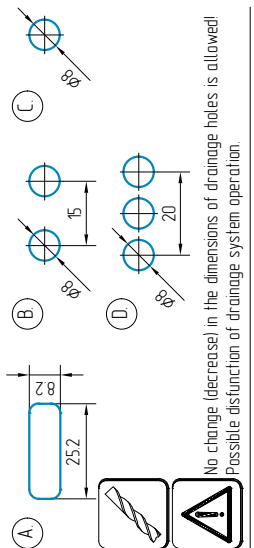
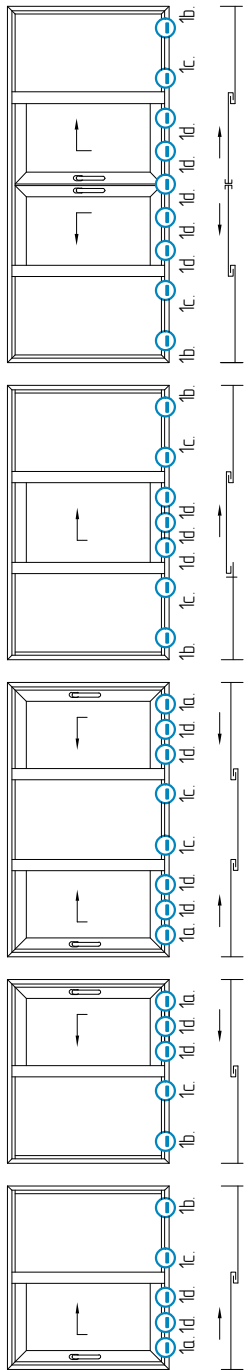

No change (decrease) in the dimensions of drainage holes is allowed!
Possible disjunction of drainage system operation.

AYPC.C48.0919M-01

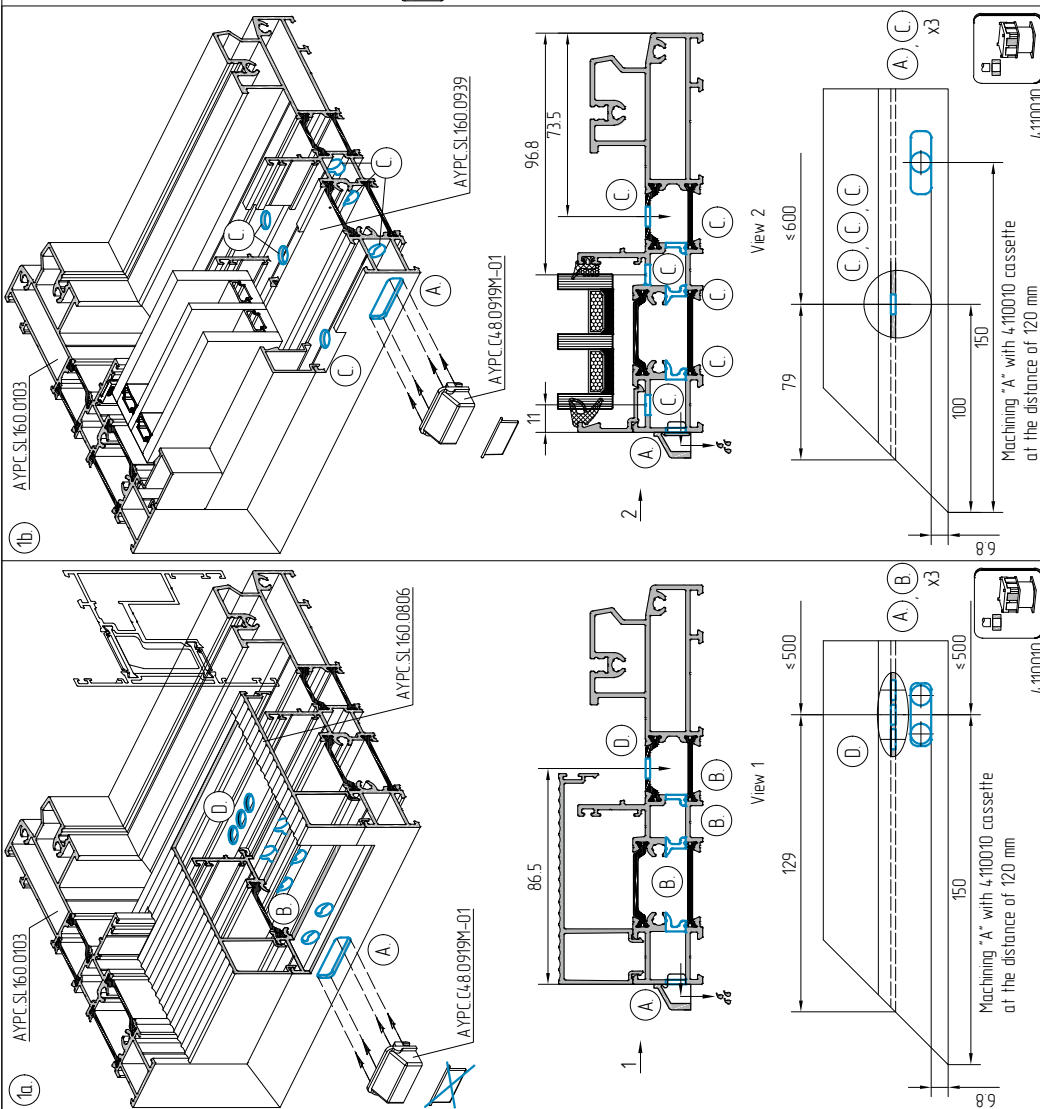

COSMO HD-100.412
* - Drill technical holes along to axle for frame internal parts seating

AYPC.SI.160.0806

AYPC.SI.160.0103

AYPC.C48.0919M-01

AYPC.SI.160.0806

AYPC.C48.0919M-01

* - see the section "Calculation examples"

View 2
4110010
Machining "A" with 4110010 cassette at the distance of 120 mm

View 1
4110010
Machining "A" with 4110010 cassette at the distance of 120 mm

Machining of AYPC.SL160.0923 drain profiles. Drainage system

Outside view

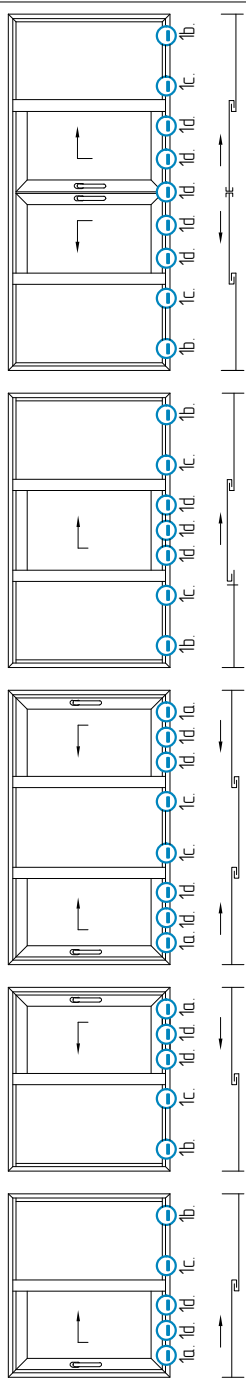

(A), (B), (C), (D) see page 08.12

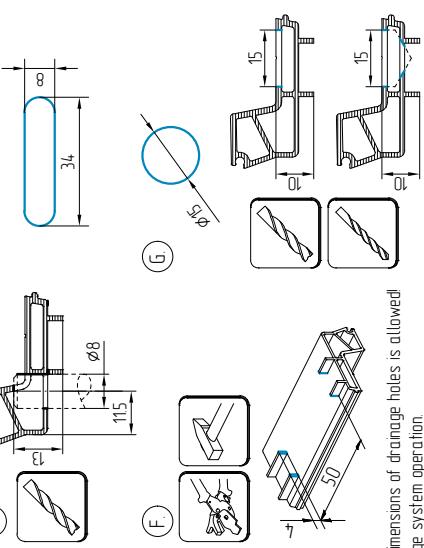

No change (decrease) in the dimensions of drainage holes is allowed! Possible disjunction of drainage system operation.

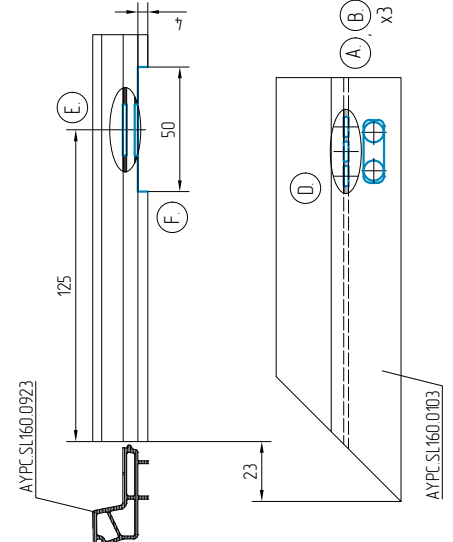
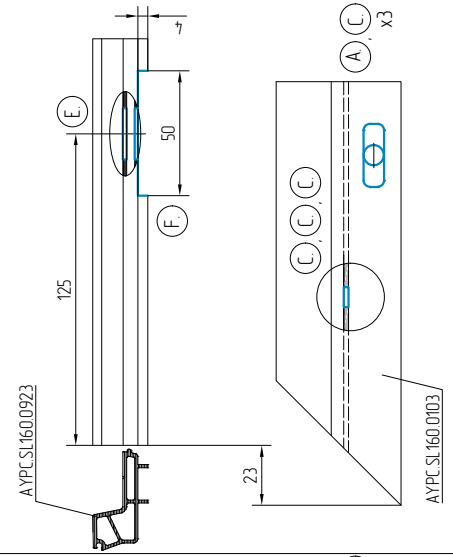
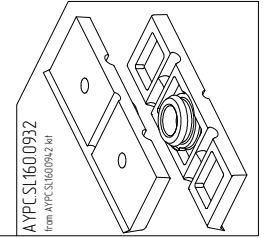
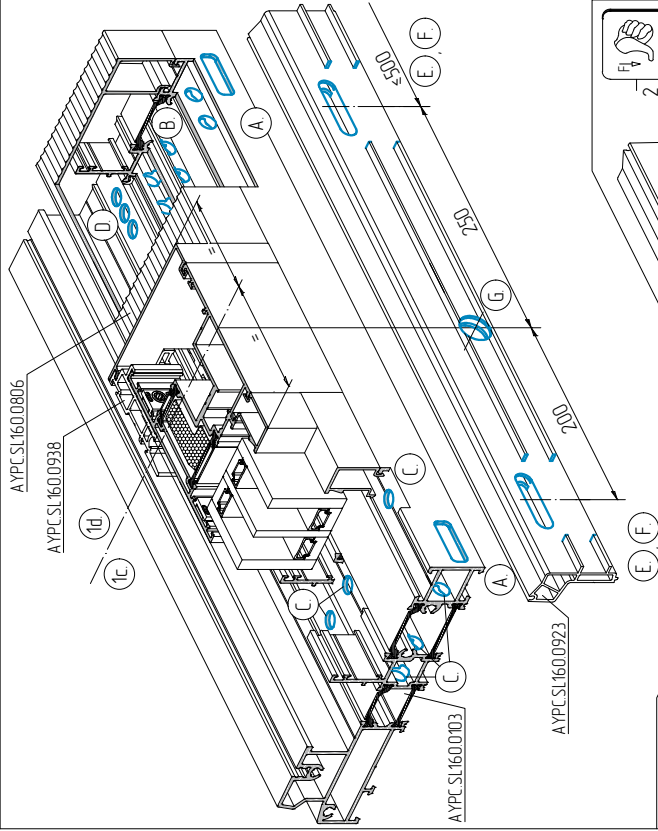
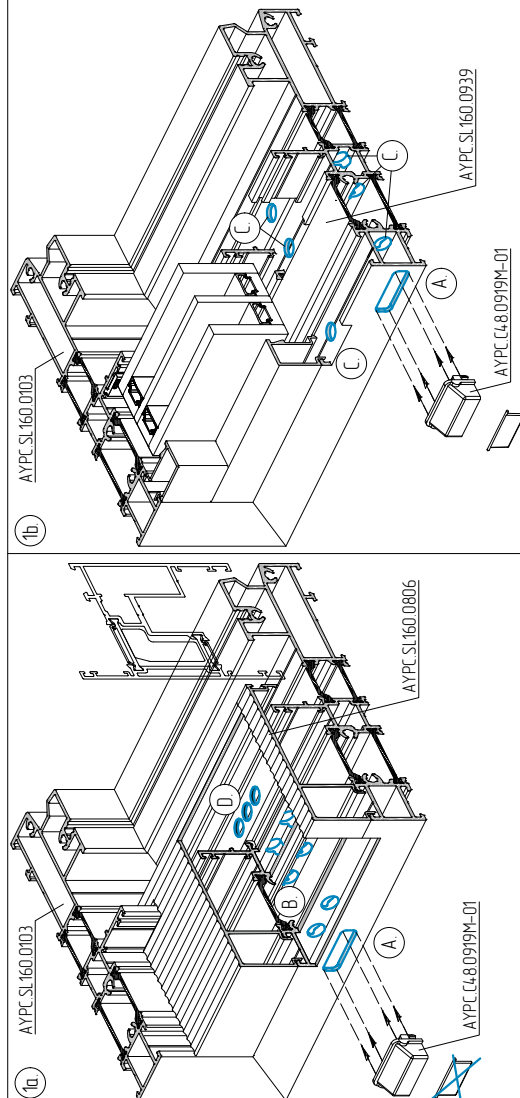

Machining of AYPC.SI.160.0104 frame profiles. Drainage system

Outside view

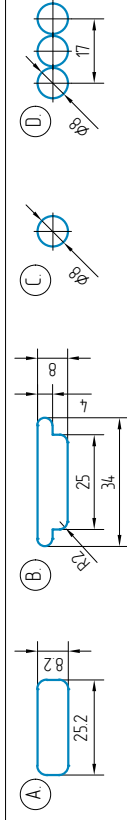
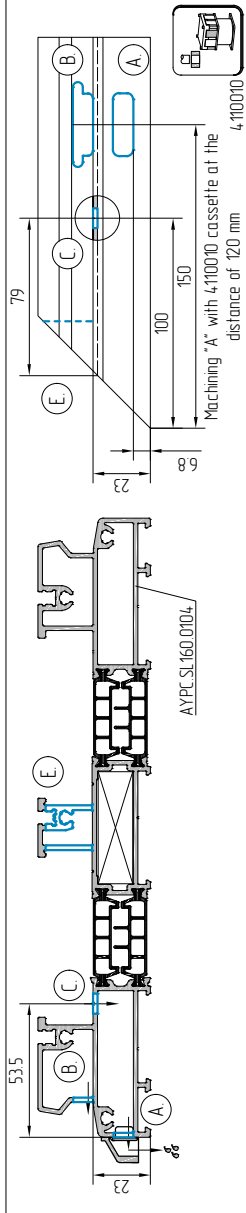
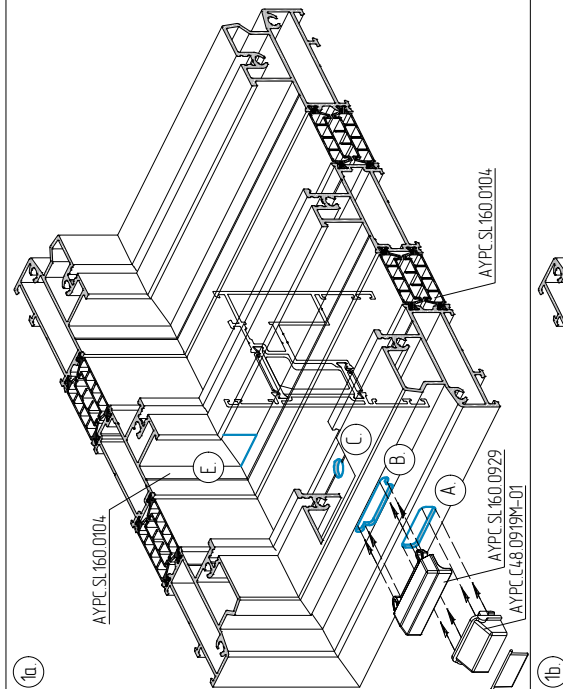
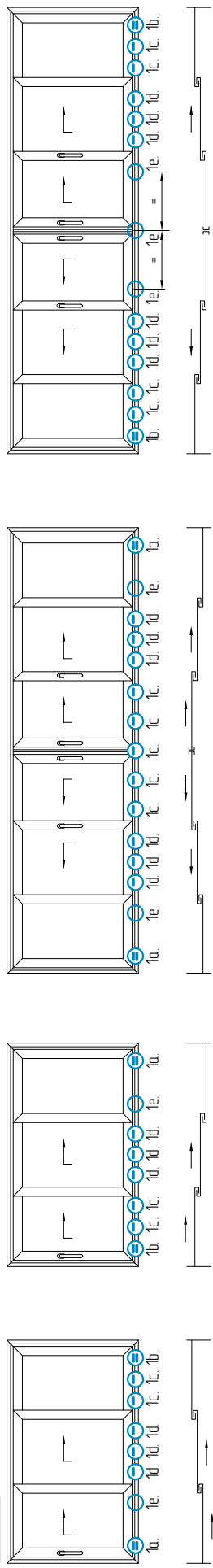

No change (decrease) in the dimensions of drainage holes is allowed!
Possible distortion of drainage system operation.

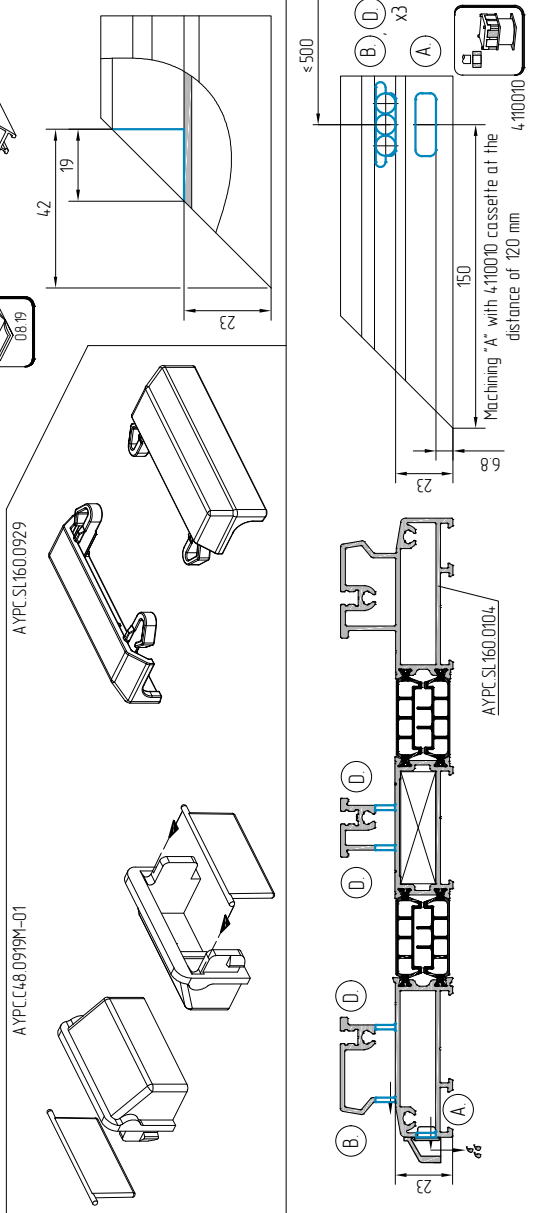
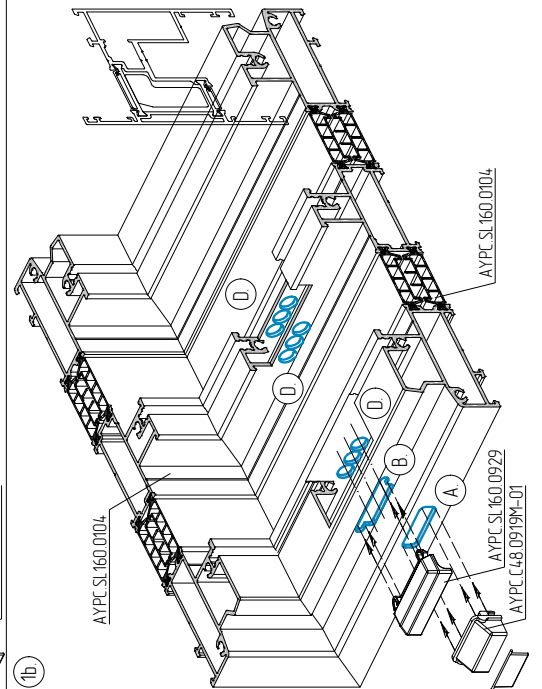

Machining of AYPCLSL160.0104 frame profiles: Drainage system

Outside view

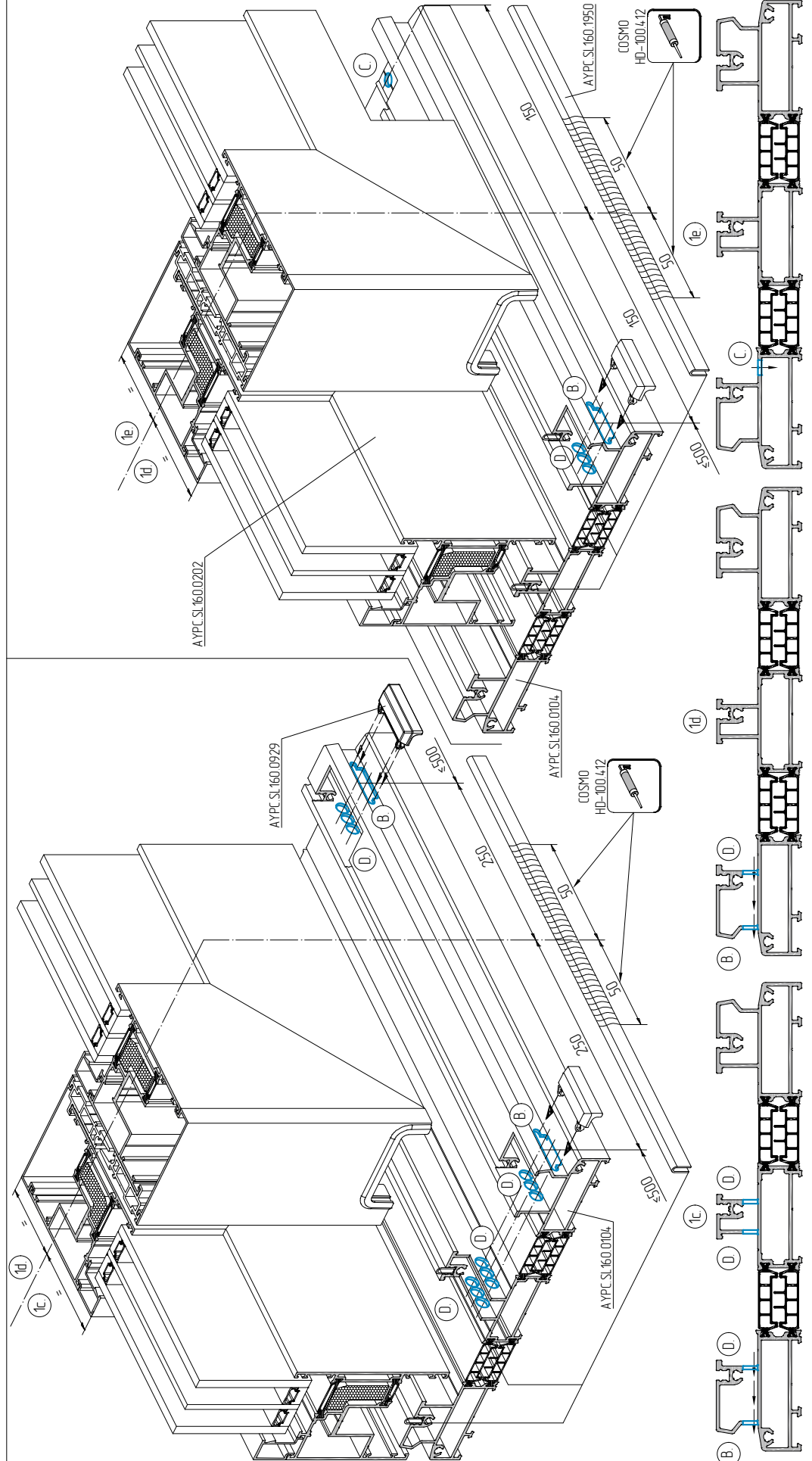
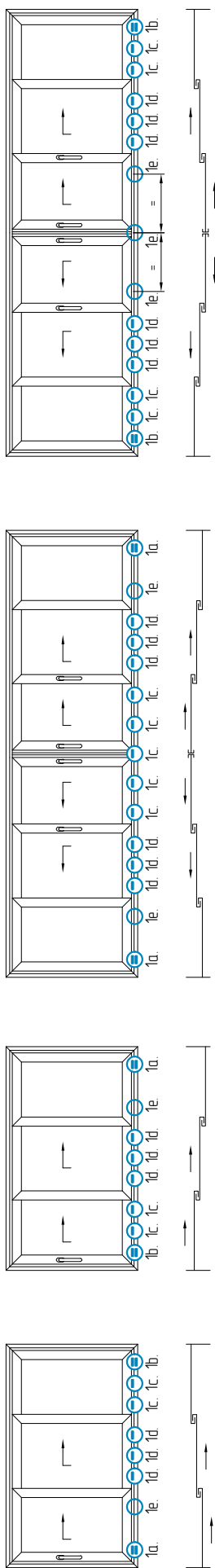

Machining of AYPC.SL160.0920 drain profiles. Drainage system

Outside view

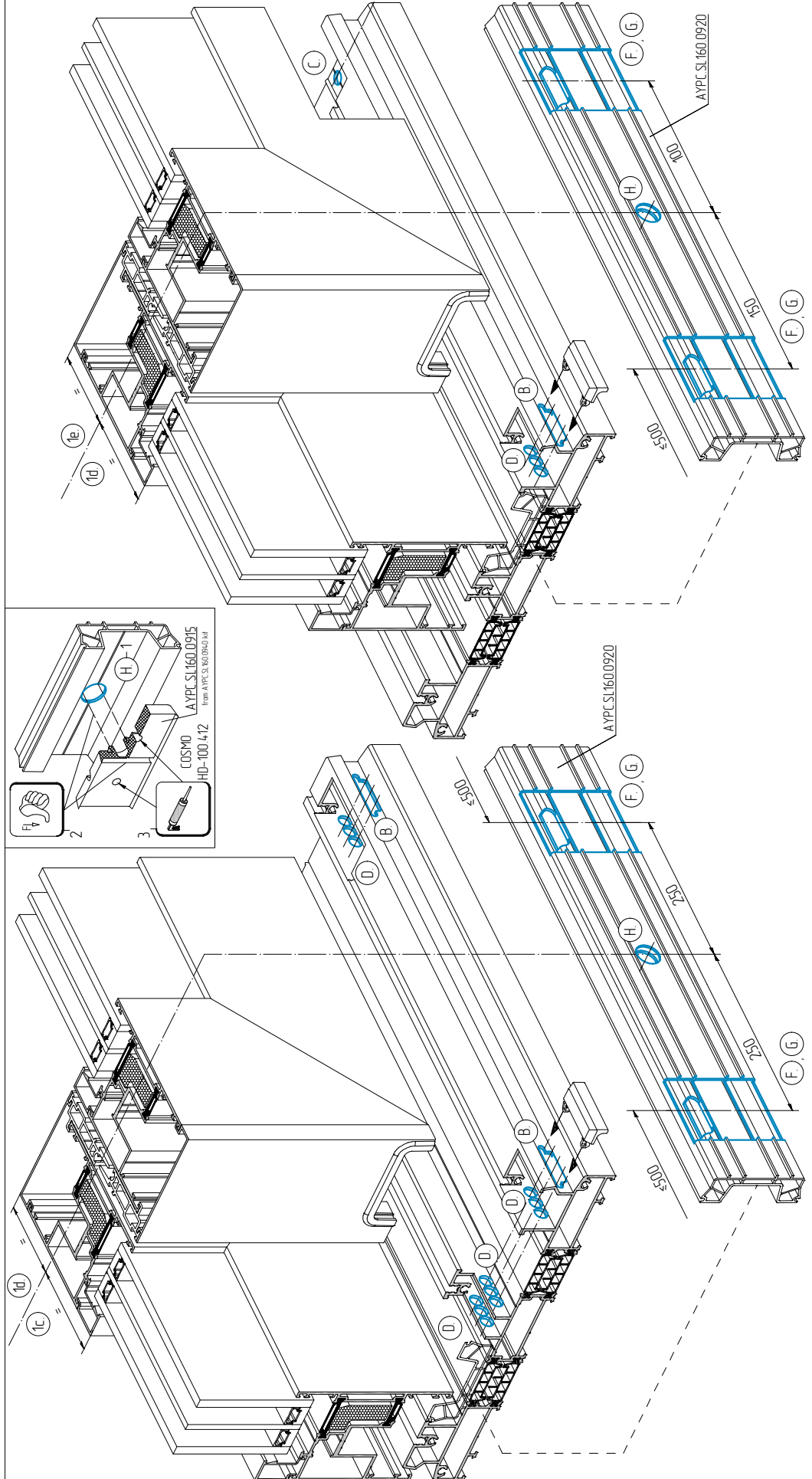
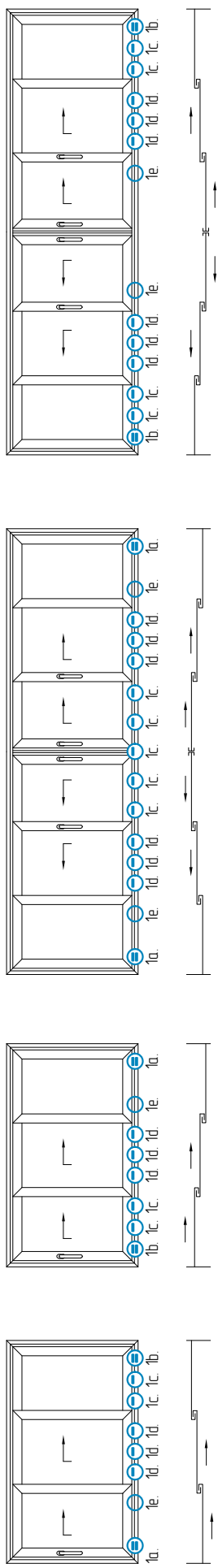

Cutting scheme of 5-7 encapsulating inserts from AYPC.SI.160.0946

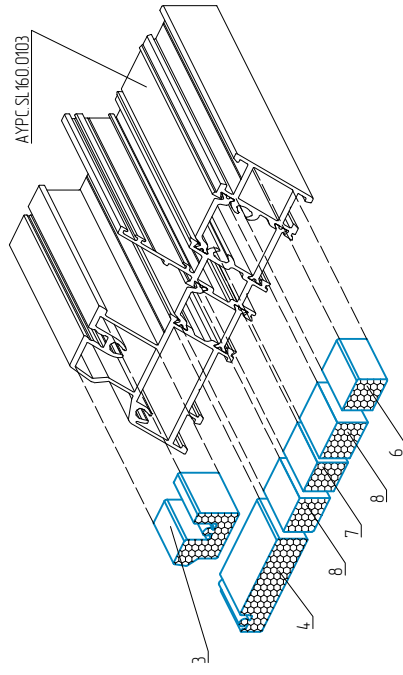
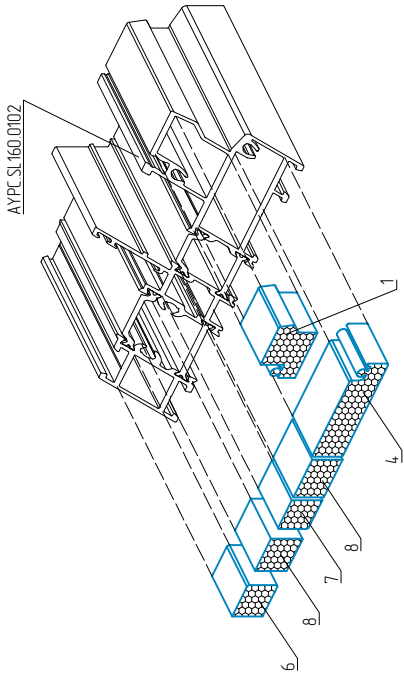
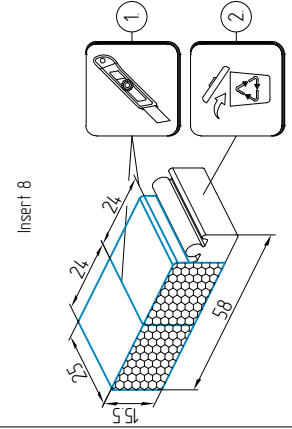
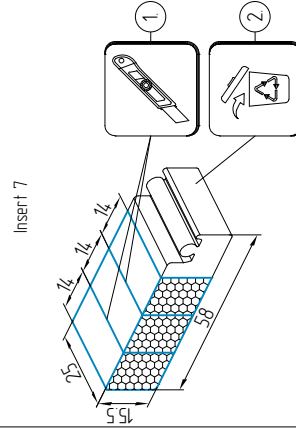
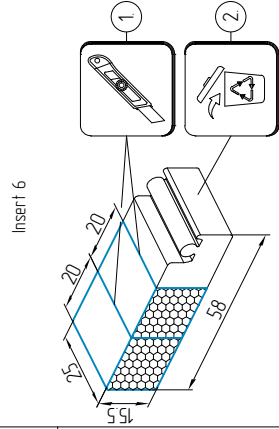
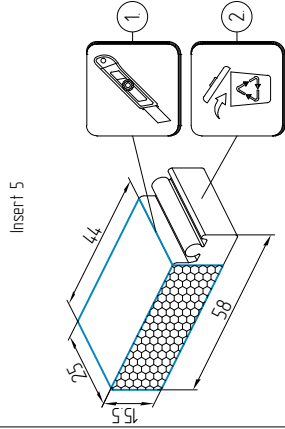

Kit of encapsulating inserts

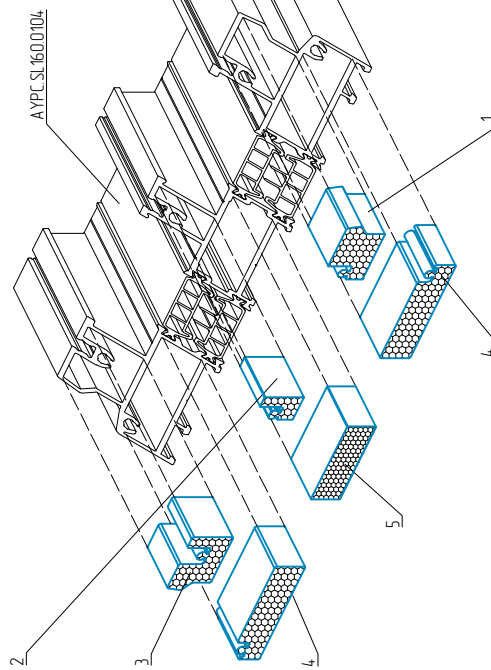
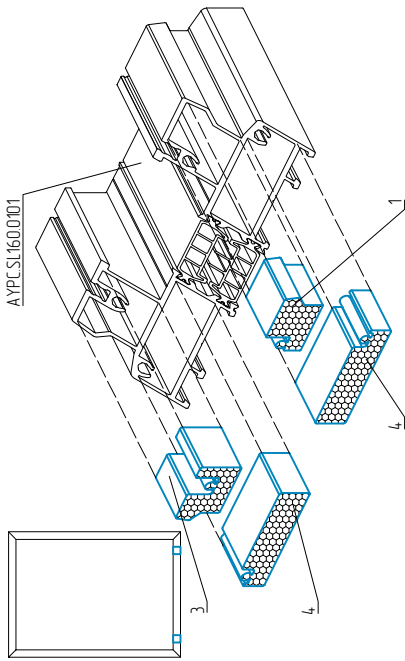

encapsulating inserts

1. AYPC.SI.160.0943

2. AYPC.SI.160.0944

3. AYPC.SI.160.0945

4. AYPC.SI.160.0946

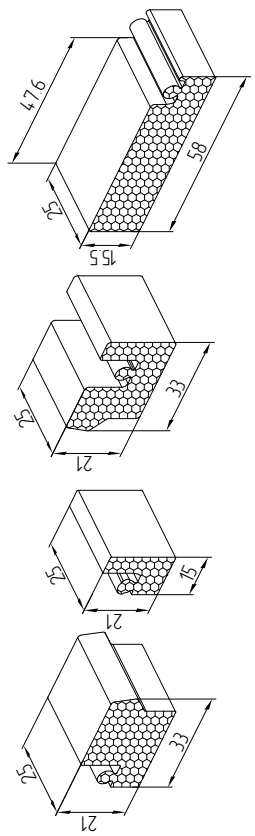

Subsequence of sealing for bottom frame profile

- 1 Preparation of encapsulating inserts
Skip over step 1 for AYPCLSL160.0101 frame
Only for AYPCLSL160.0102, AYPCLSL160.0103, AYPCLSL160.0104 frames.

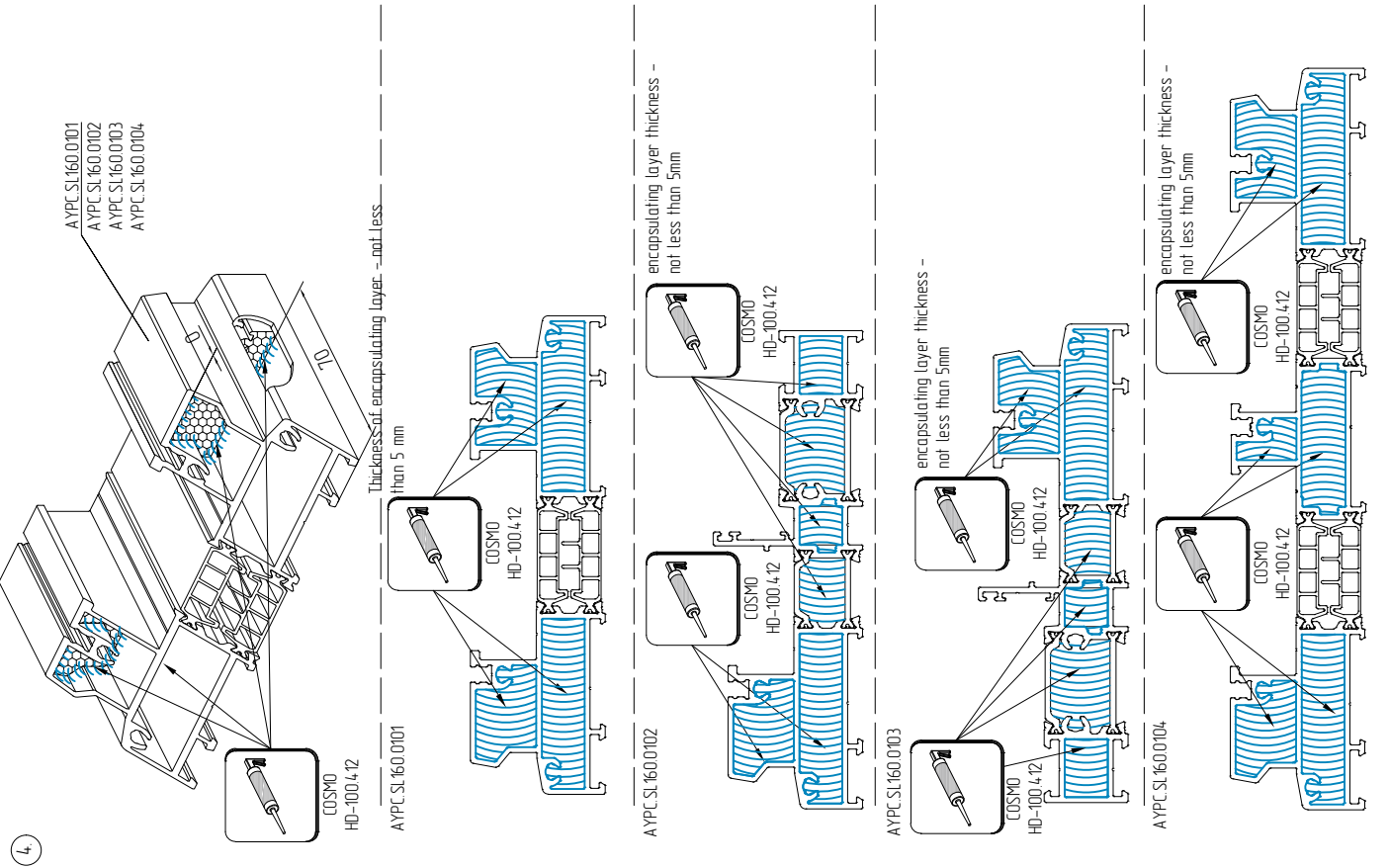
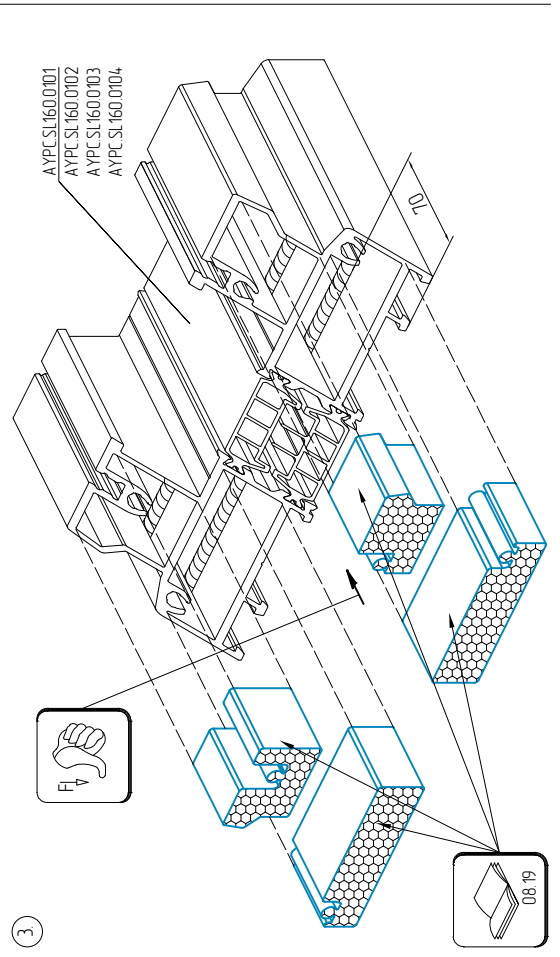
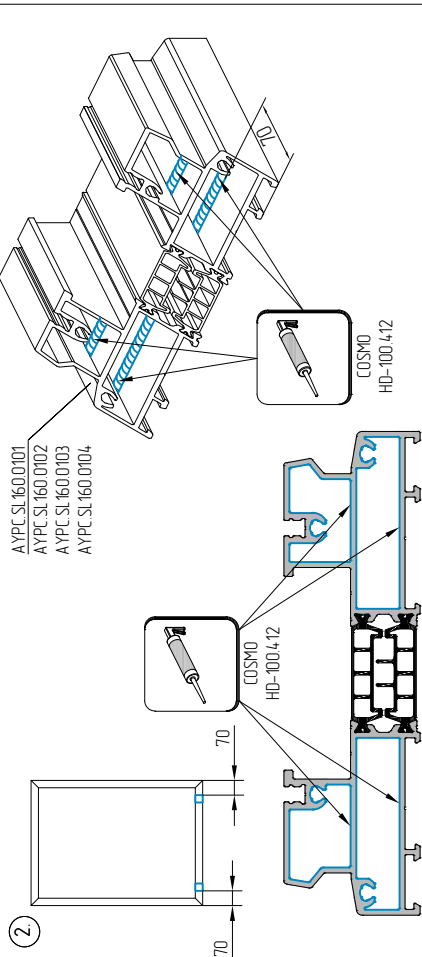
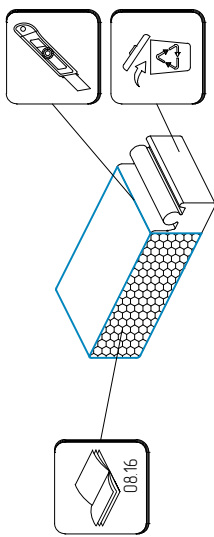

Assemblage of frame corner connection

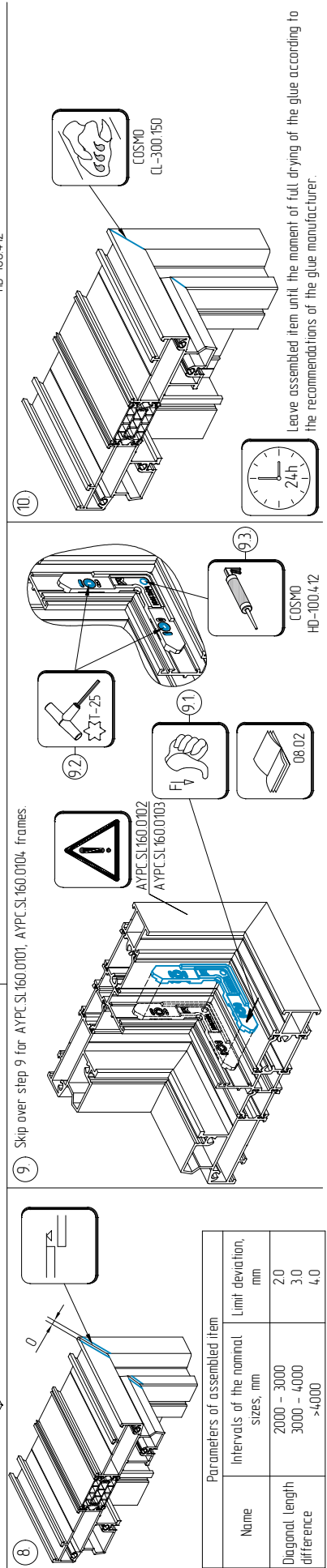
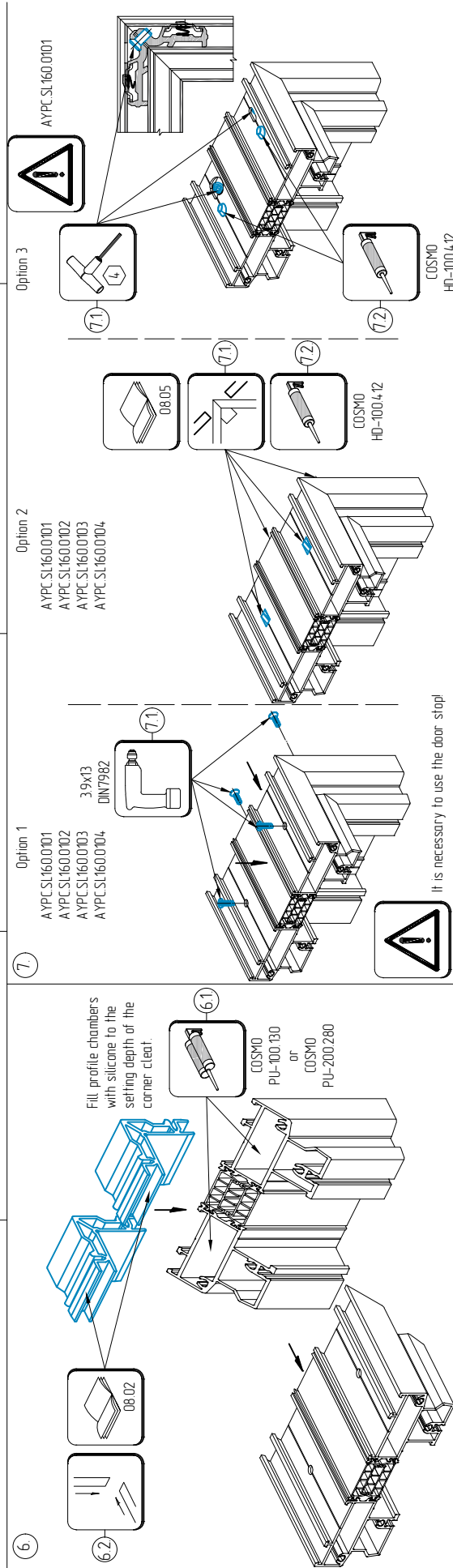
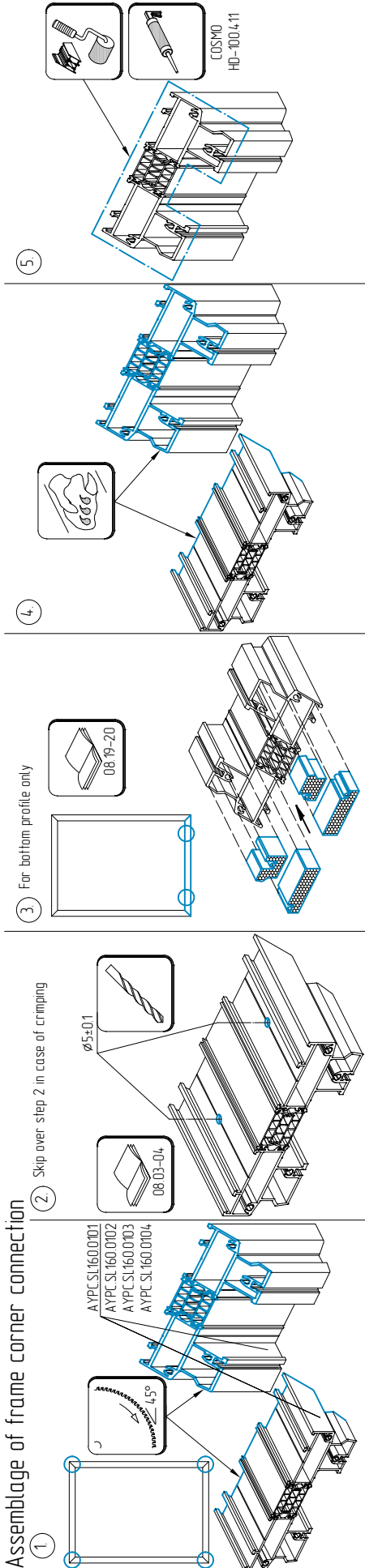

Leave assembled item until the moment of full drying of the glue according to the recommendations of the glue manufacturer.

Parameters of assembled item		
Name	Limit deviation, mm	
Diagonal length difference	Intervals of the nominal sizes, mm	2.0
		3.0
		4.0

Assemblage of sash corner connection

1 $\alpha = 45^\circ$
APPL SL160.0202

2 Skip over step 2 in case of crimping $\varnothing 5 \pm 0.1$

3

4

5 Fill profile chambers with silicone to the setting depth of the corner cleat.
COSMO PU-100.130 or COSMO PU-200.280

6 From the side of hardware installation
Pin 5x10 DIN63250
3.9x13 DIN7982
It is necessary to use the door stop!

7

8

9 COSMO PU-300.150
COSMO HD-100.4.12
24h

Parameters of assembled item	
Name	Diagonal length difference
Intervals of the nominal sizes, mm	Limit deviation, mm
1000 - 2000	10
2000-3000	20
>3000	30

Fabrication scheme for the fixed lights on AYPC.SL160.0101, AYPC.SL160.0104 frames

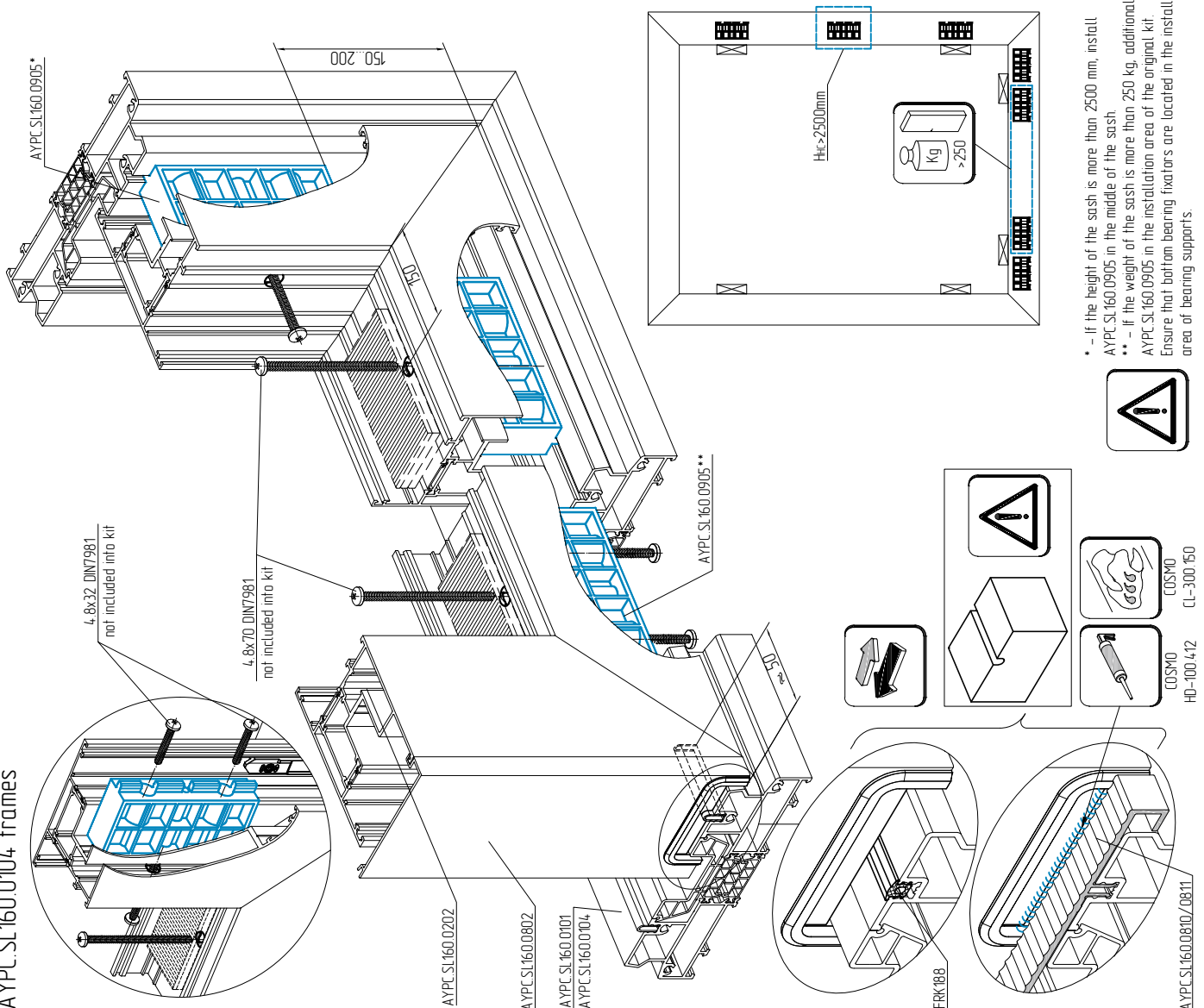
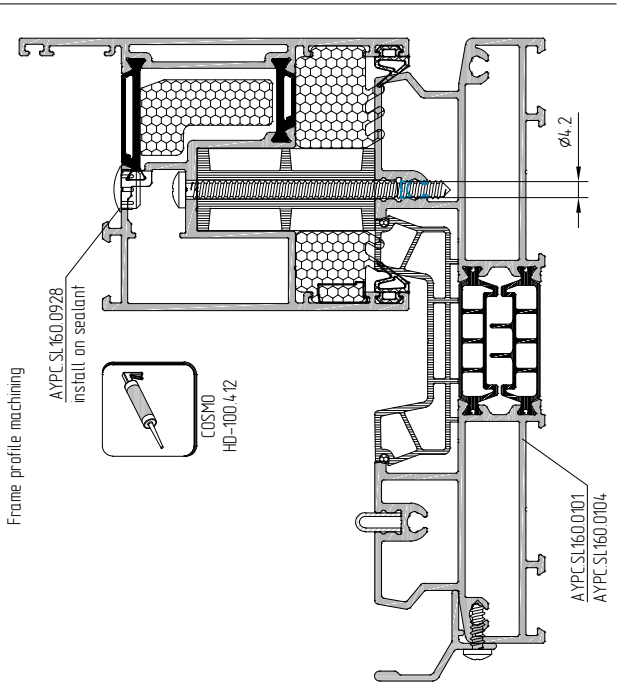
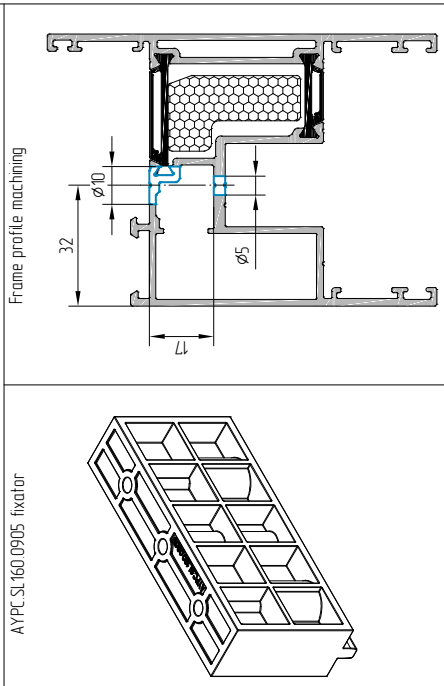
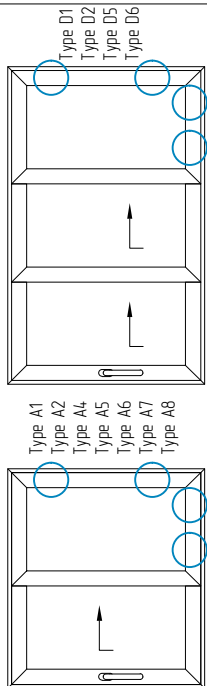

Profile machining and assemblage plan for fixed part of AYPC.SL160.0102, AYPC.SL160.0103 frames

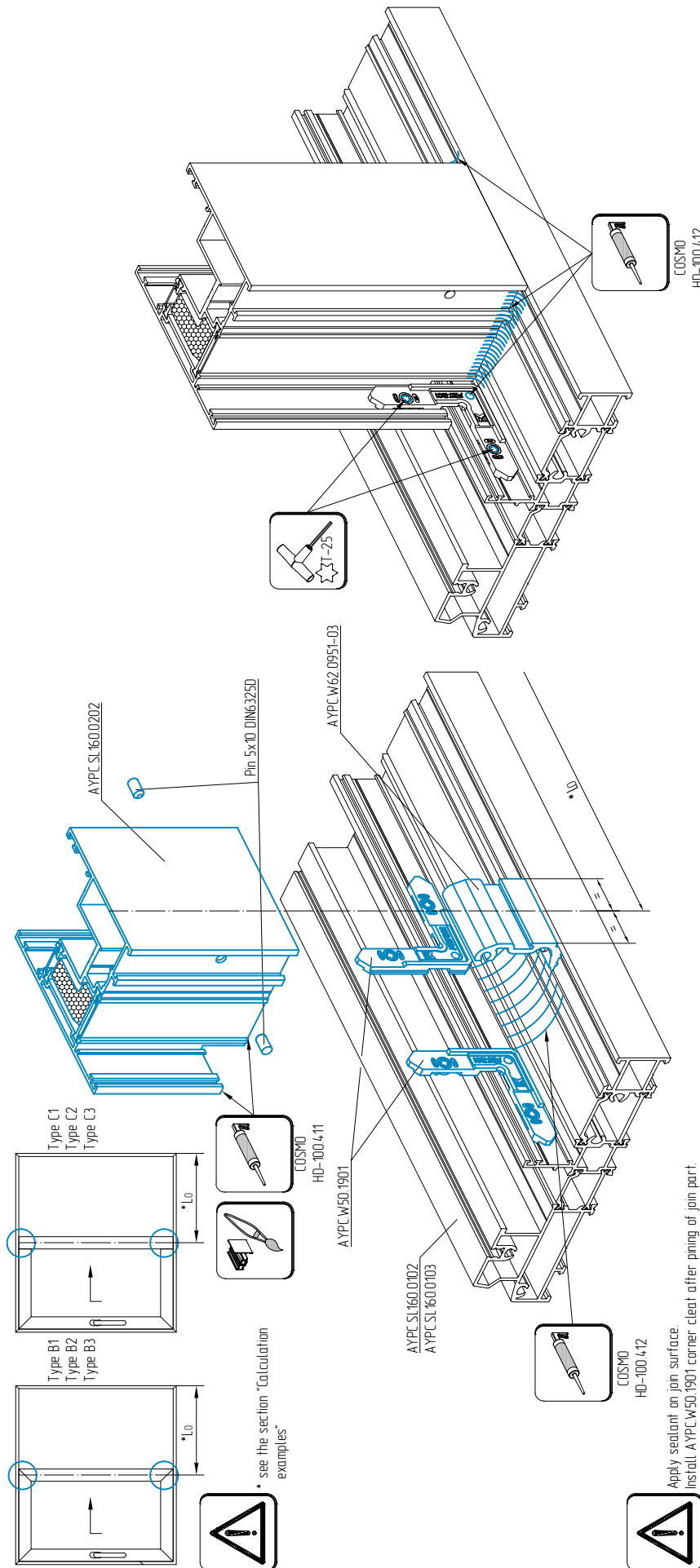

Sash fixing elements

Original profile - AYPC.W62.0701
 AYPC.W62.0951-03
 5x10 DIN6325D

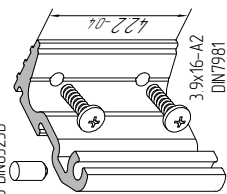

Comply with the number of holes and installed pins specified in the instruction.
 Quantity reduction of pins and holes will result in loss of strength characteristics of the structure.
 Prevent replacement of pins with self-tapping screws!

Machining of sash profile

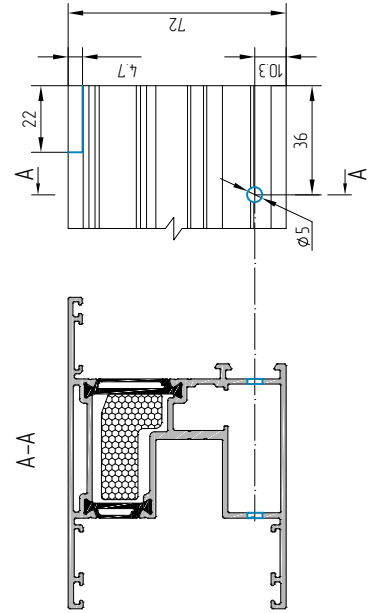

Machining plan of interlock. Installation of interlock and AYPCL160.0940 ledge kit

1 Installation of AYPCL160.0912, PE2x26 thermal inserts and AYPCL160.0802 end profile

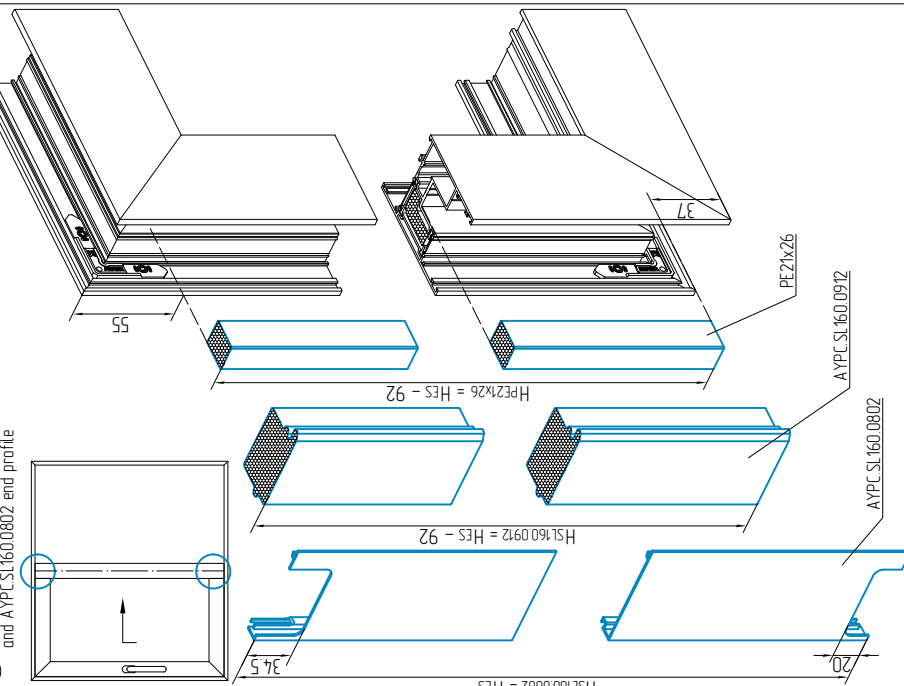

Machining of AYPCL160.0802 end profile

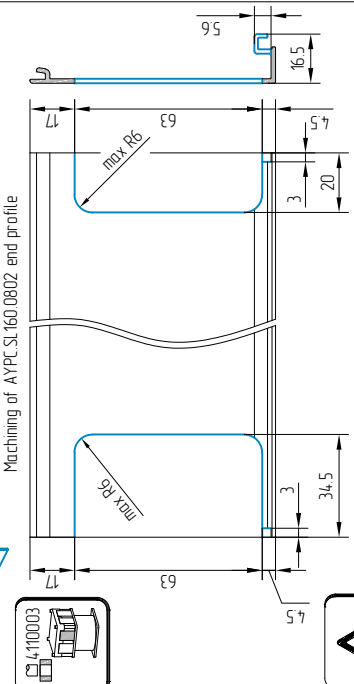

2 Installation of AYPCL160.0938 interlock

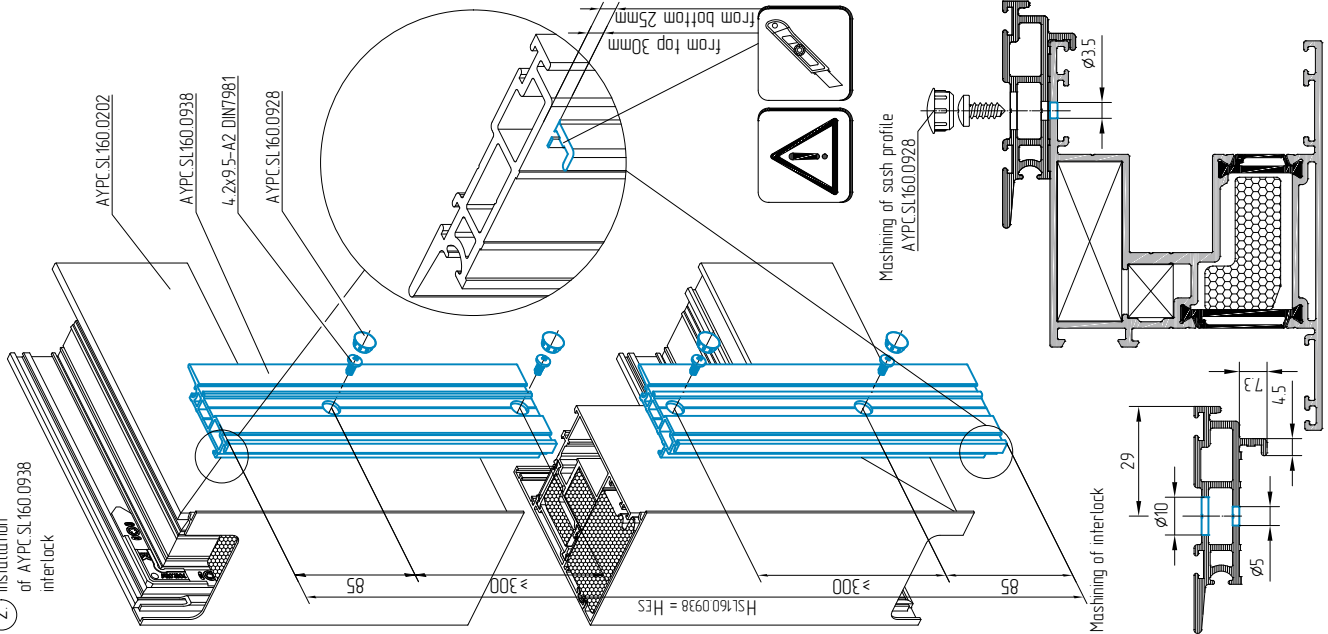

Machining of sash profile AYPCL160.0928

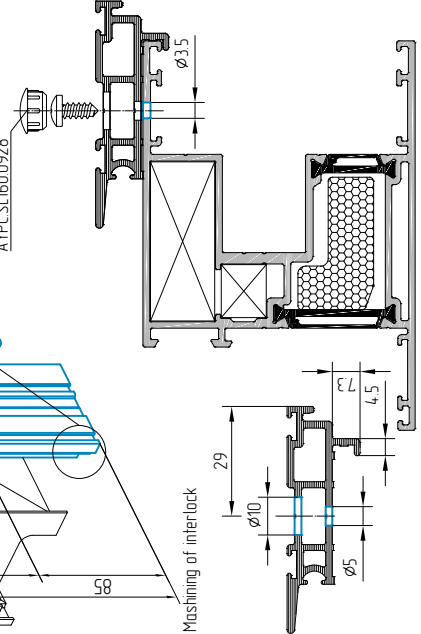

3 Installation of AYPCL160.0940 ledge kit

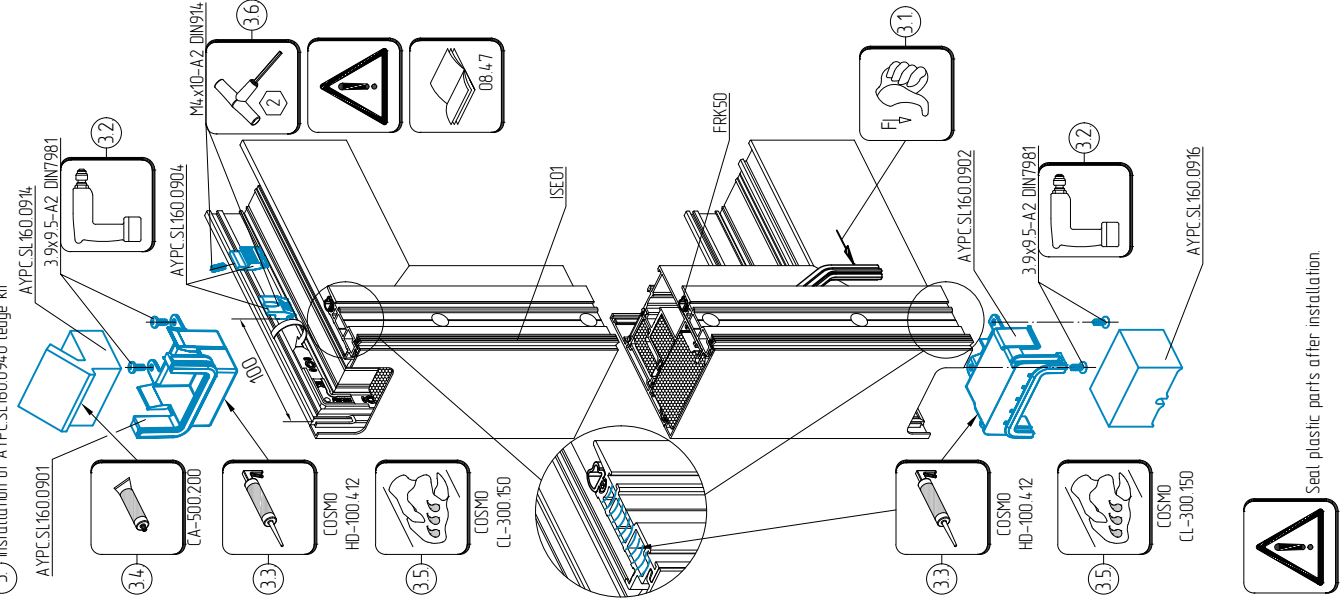

Seal plastic parts after installation

Machining and installation of interlock

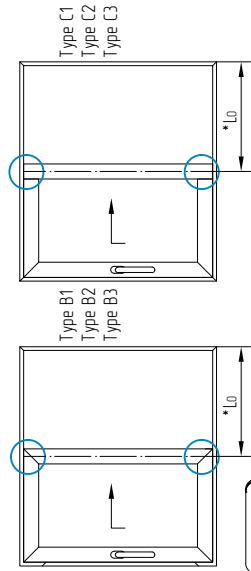

* see the section 07 "Calculation examples"

1 Installation of AYPC.SI.160.0912, PE2x26 foamed insert and AYPC.SI.160.0802 end profile.

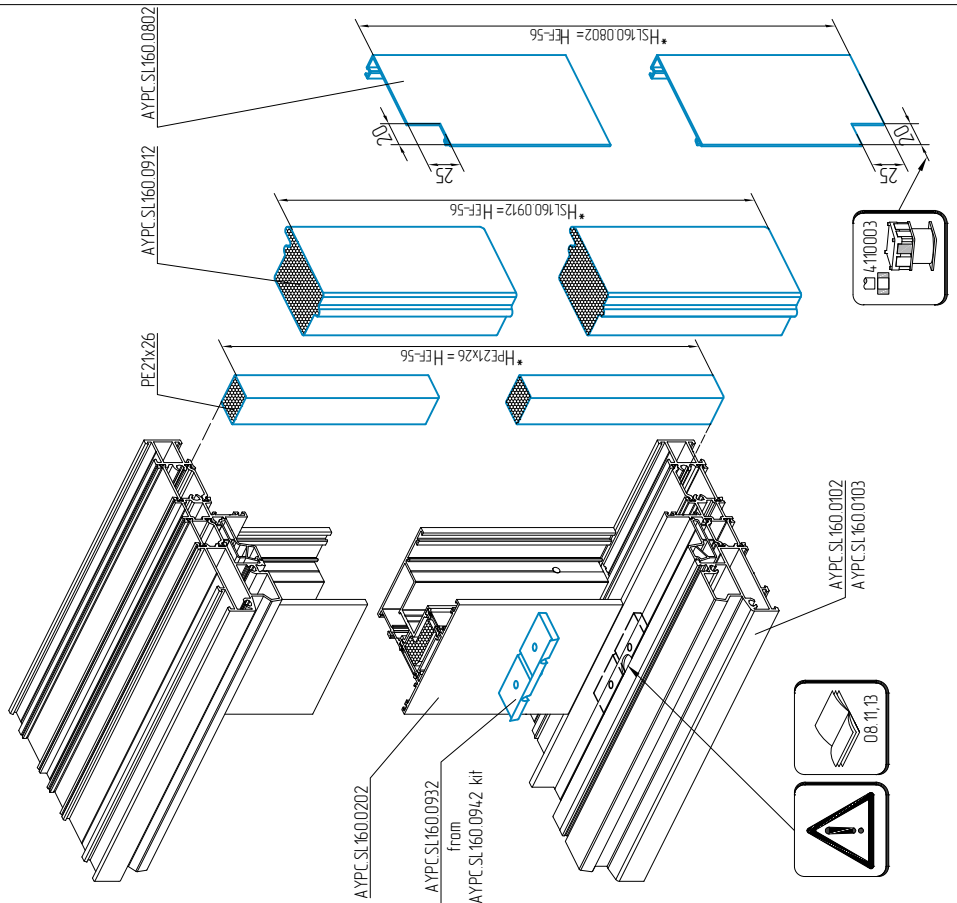

2 Installation of AYPC.SI.160.0938 interlock

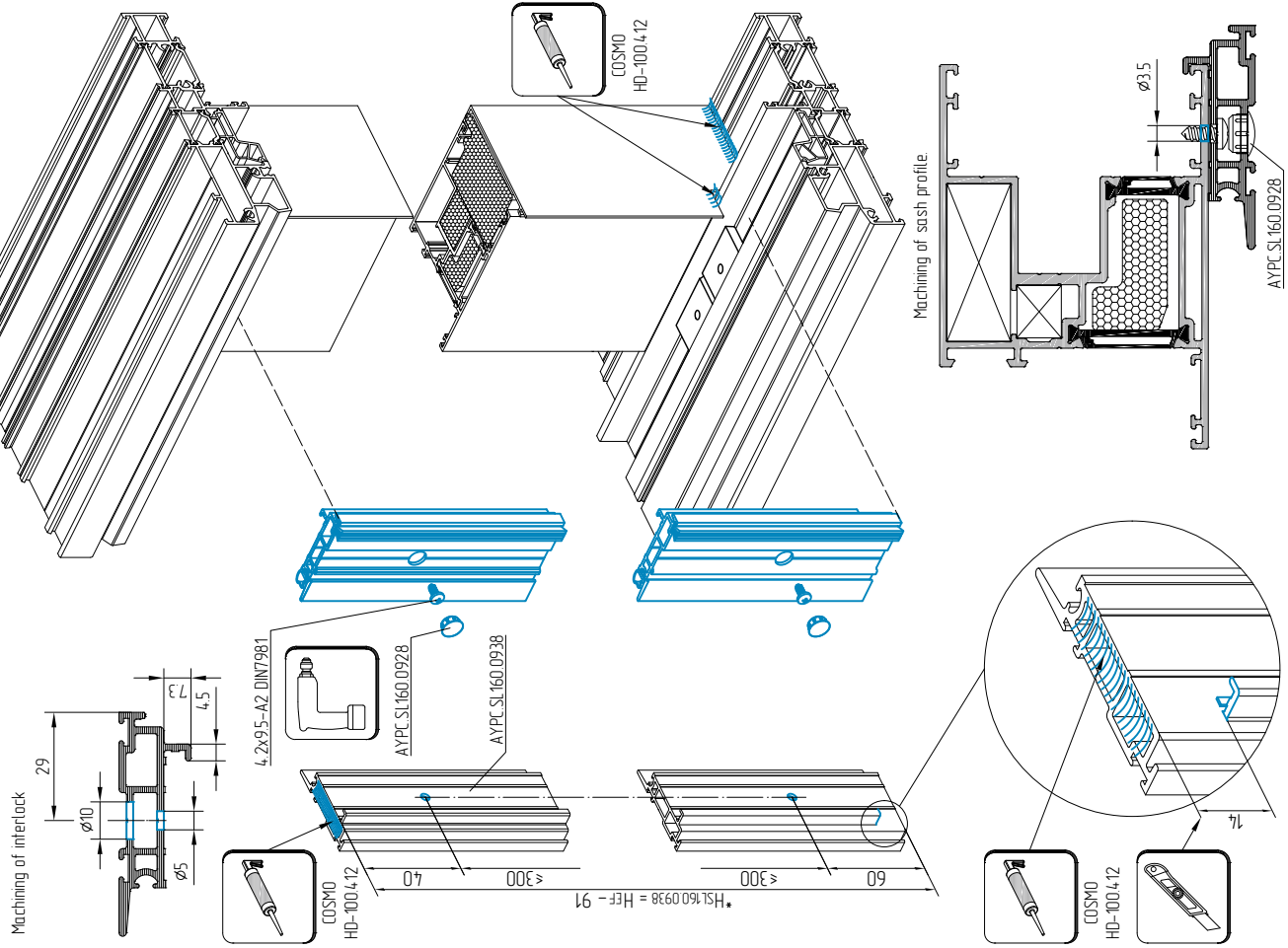

Machining of AYPCLSL160.0813 interlock. Assembling of interlock and accessories

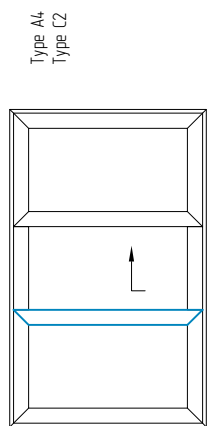

Machining of AYPCLSL160.0813 interlock

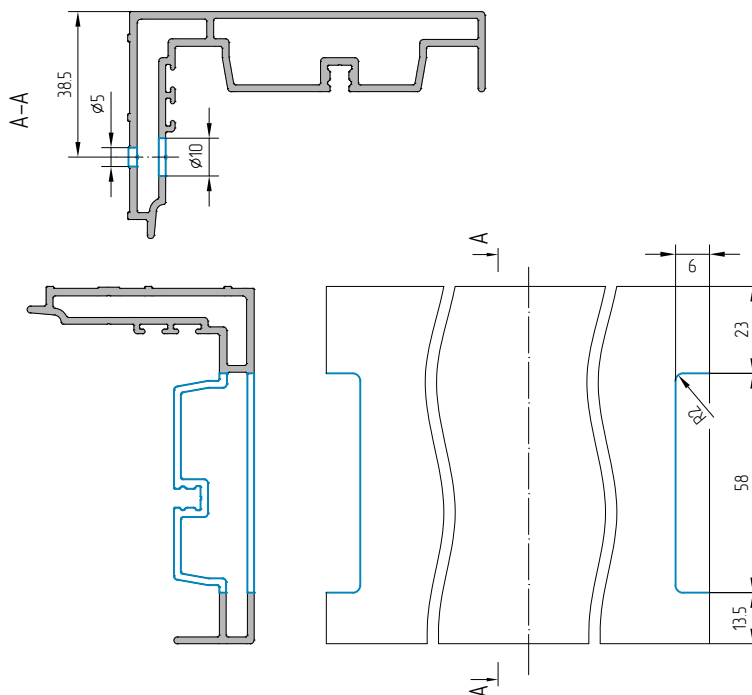

* - If it is recommended to specify dimensions on site

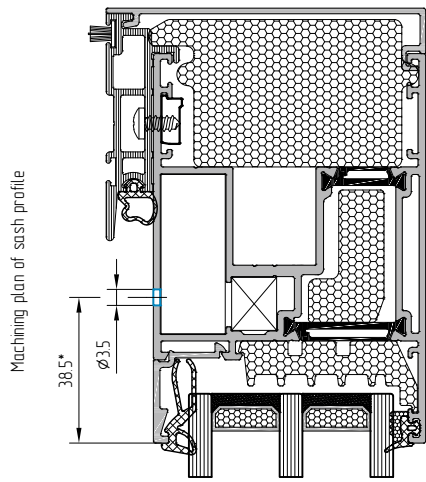

Machining plan of sash profile

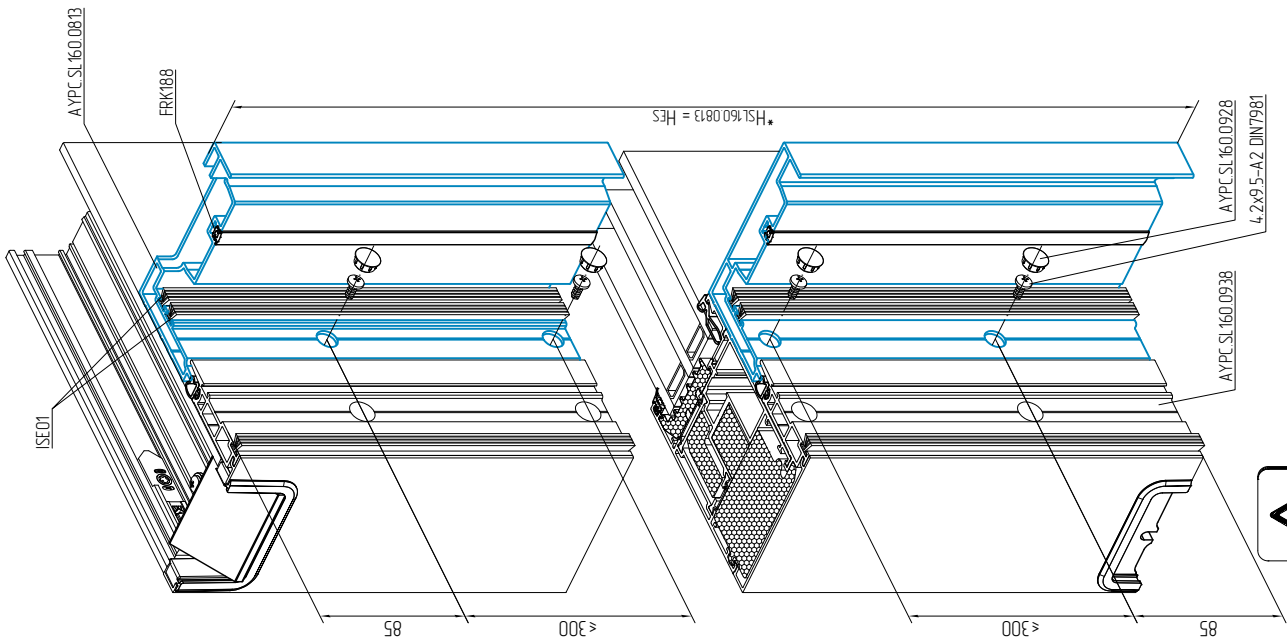
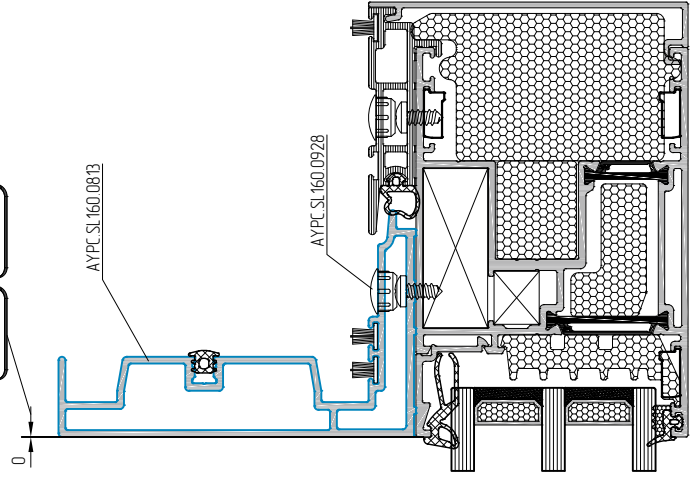
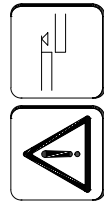

Install AYPCLSL160.0813 interlock after sash mounting

Installation of drain profiles on AYPC.SL160.0101 and AYPC.SL160.0104 frames

External view, for all types

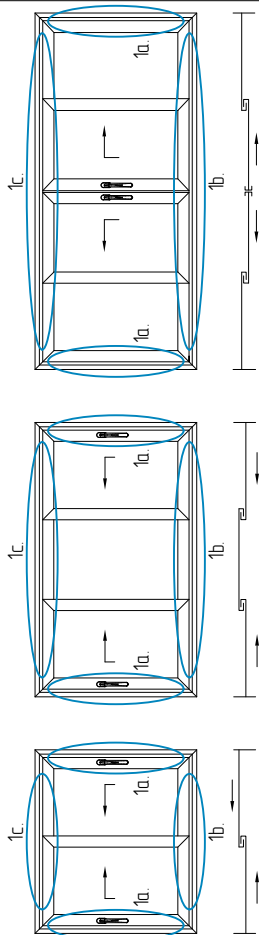

11 Machining of AYPC.SL160.0920 and AYPC.SL160.0921 drain profiles

Machining of AYPC.SL160.0920 drain profile

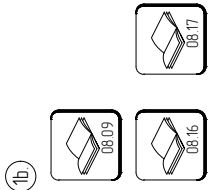
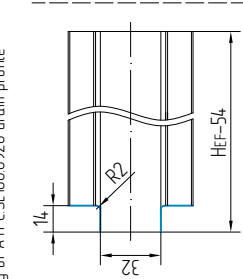

Machining of AYPC.SL160.0921 drain profile

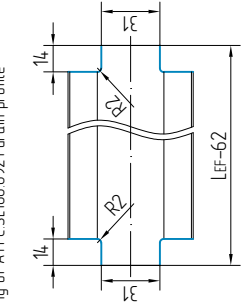

12 Machining of injection holes.

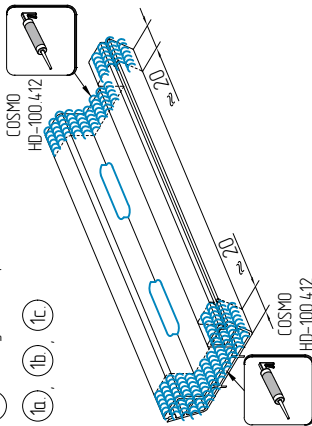
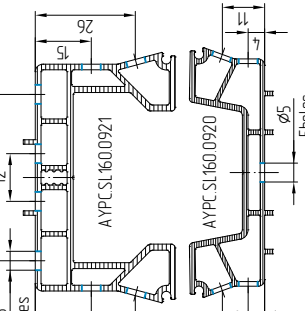
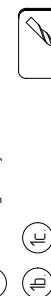

2.1 Sealing of drain profiles internal chambers

2.2 Sealing of drain profiles internal chambers, see the section 12

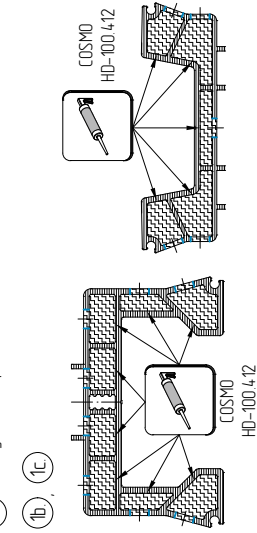

3 Machining of AYPC.SL160.0948 sealing cord

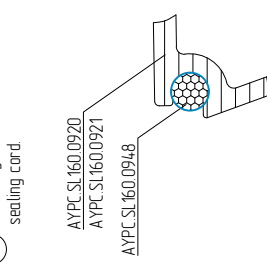

4 Sealing of frame profiles at the corner connection joint and along the symmetry axis of adjacent sashes. Installation of AYPC.SL160.0920

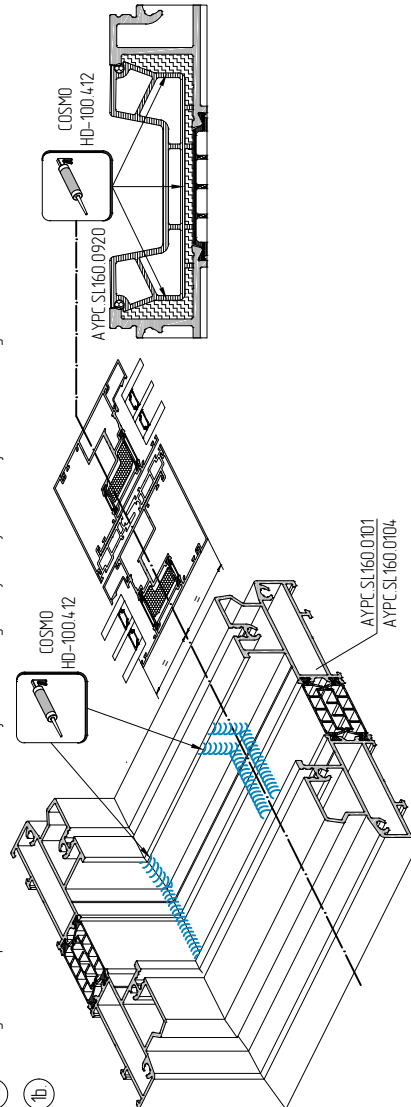

5.1 Seal frame before AYPC.SL160.0920 drain profile installation.

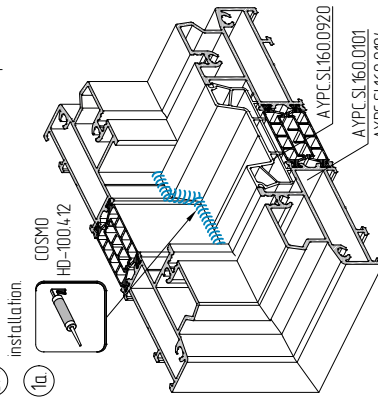

5.2 Installation of AYPC.SL160.0920 vertical drain profiles

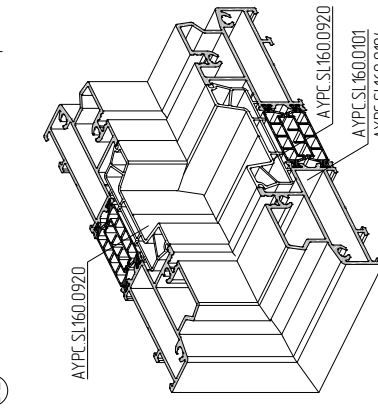

6.1 Seal frame profiles along ledge symmetry axis and adjacent sashes. See more in the section 4.

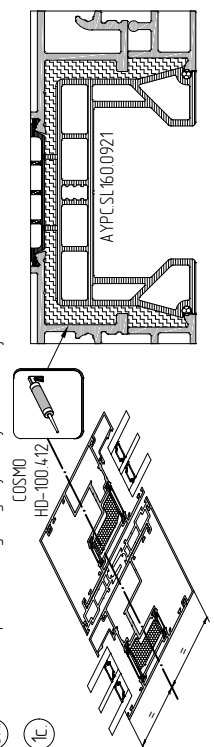

6.2 Installation of AYPC.SL160.0921 drain profile.

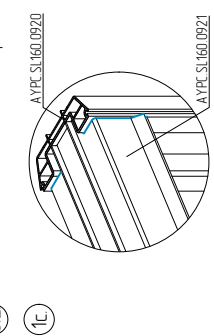

7 Apply black sealant on angle joints after installing all drain profiles - remove excess making smooth transition

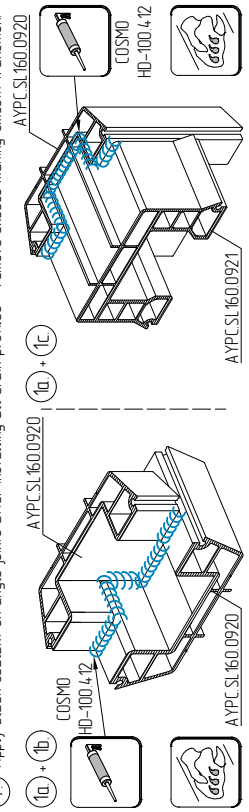

Installation of drain profiles on AYPC.SI.160.0102 and AYPC.SI.160.0103 frames

External view, for all types

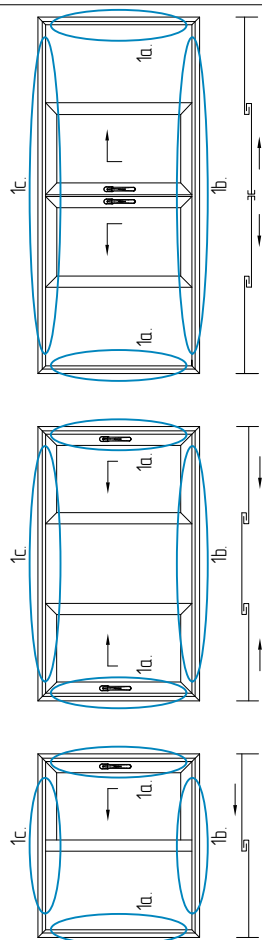

1. Machining of AYPC.SI.160.0922 and AYPC.SI.160.0923 drain profiles

Machining of AYPC.SI.160.0923 drain profiles

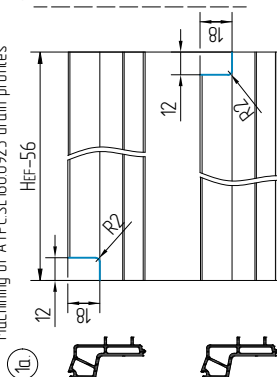

1b



1c



Machining of AYPC.SI.160.0922 drain profile

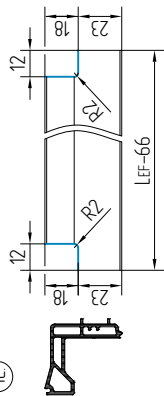

12. Machining of injection holes.

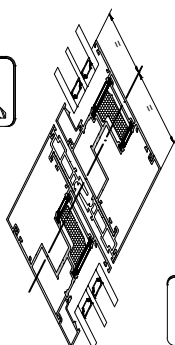

Do machining along ledge symmetry axis of adjacent sashes.

2.1 Sealing of drain profiles internal chambers

1a, 1b, 1c

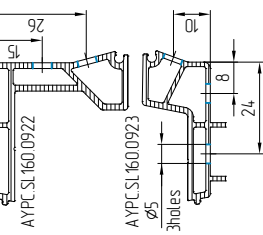

2.2 Sealing of drain profiles internal chambers, see the section 12

1a, 1b, 1c

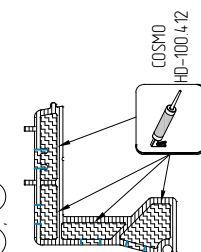

3. Installation of AYPC.SI.160.0948 sealing card

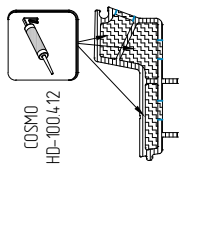

4. Sealing of frame profiles at the corner connection joint and along the symmetry axis of adjacent sashes edge. Installation of AYPC.SI.160.0923.

1b

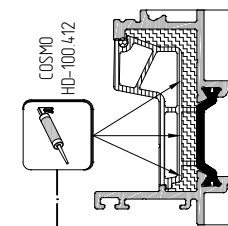

5.1 Sealing of frame before AYPC.SI.160.0923 drain profiles installation

1a

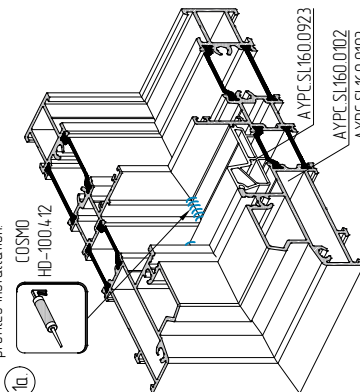

5.2 Installation of AYPC.SI.160.0923 vertical drain profiles

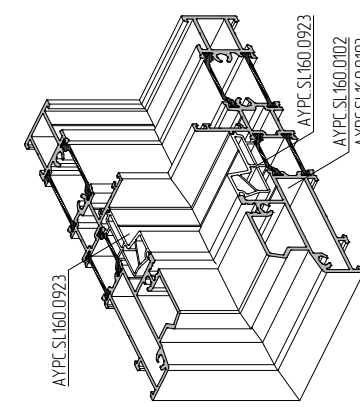

6.1 Sealing of frame profiles along ledge symmetry axis, adjacent sashes. For more information see the section 4.

1c

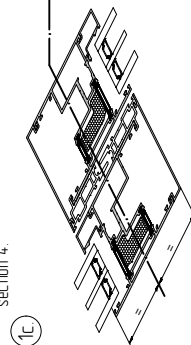

6.2 Installation of AYPC.SI.160.0921 drain profile

1c

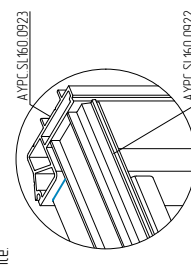

7. Apply black sealant on angle joints after installing all drain profiles - remove excess making smooth transition

1a + 1b

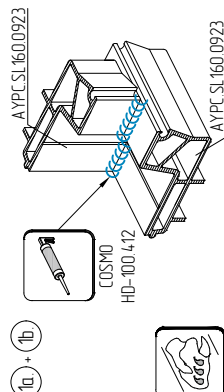

1a + 1c

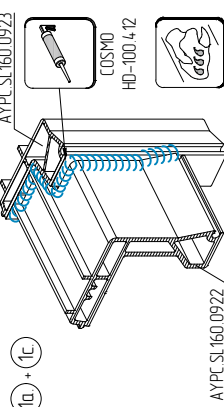

Machining and assemblage of transom bar profile for door sash connection on the angle of $\alpha = 90^\circ$

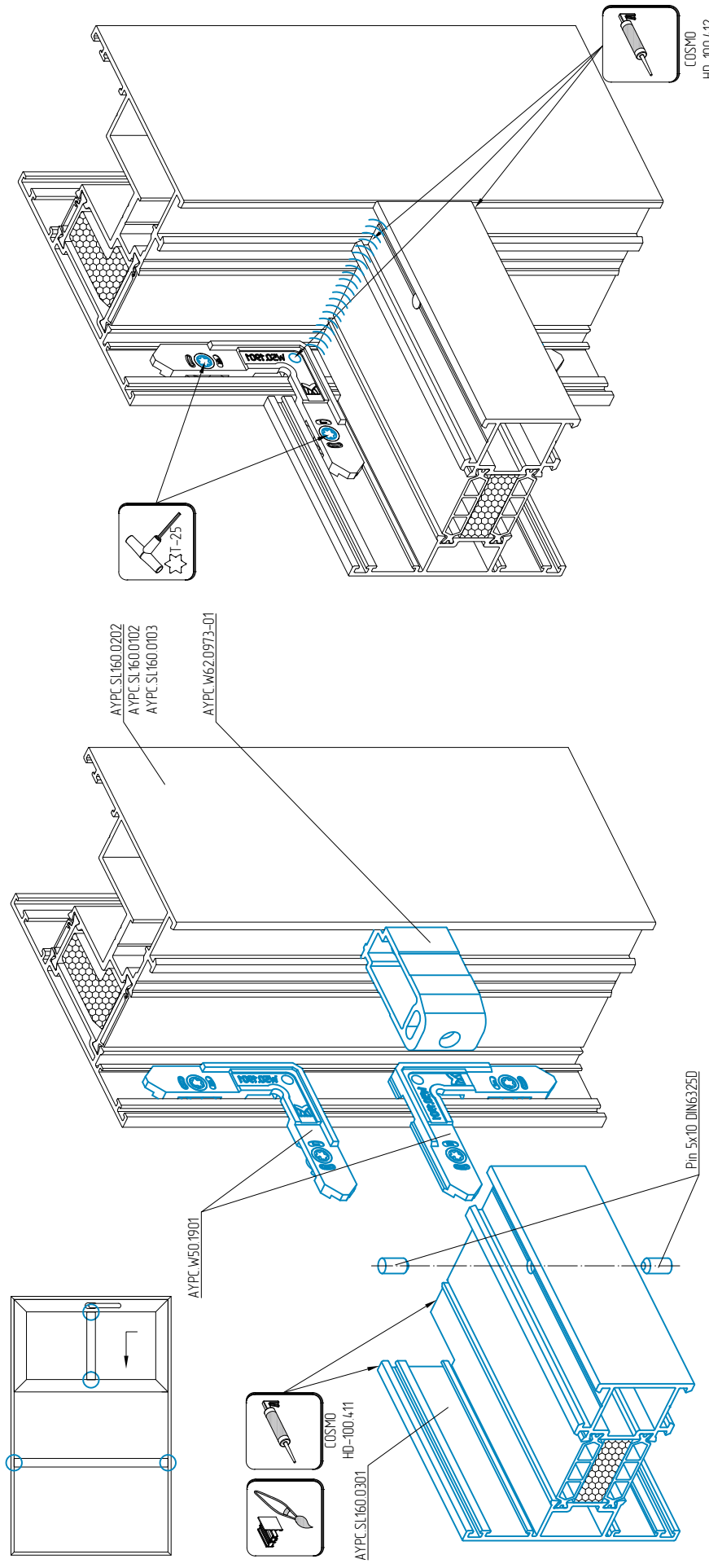

Machining of transom profile

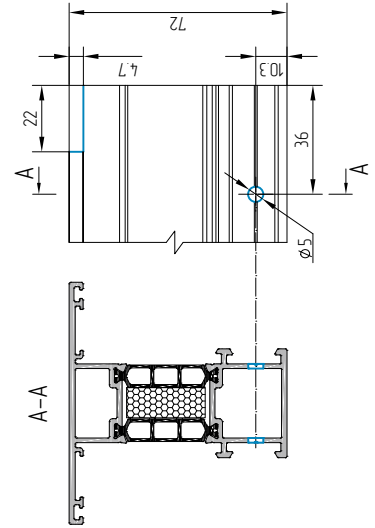

Transom fixing element

Basic profile - AYPC.W62.0705

AYPC.W62.0973-01
5x10 DIN63250

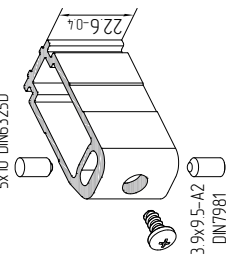

Comply with the number of holes and installed pins specified in the instruction!
Quantity reduction of pins will result in loss of strength characteristics of the door.
Do not replace the pins with self-tapping screws!



Installation of AYP.C.SI.160.0804 and AYP.C.SI.160.0805 drain profiles

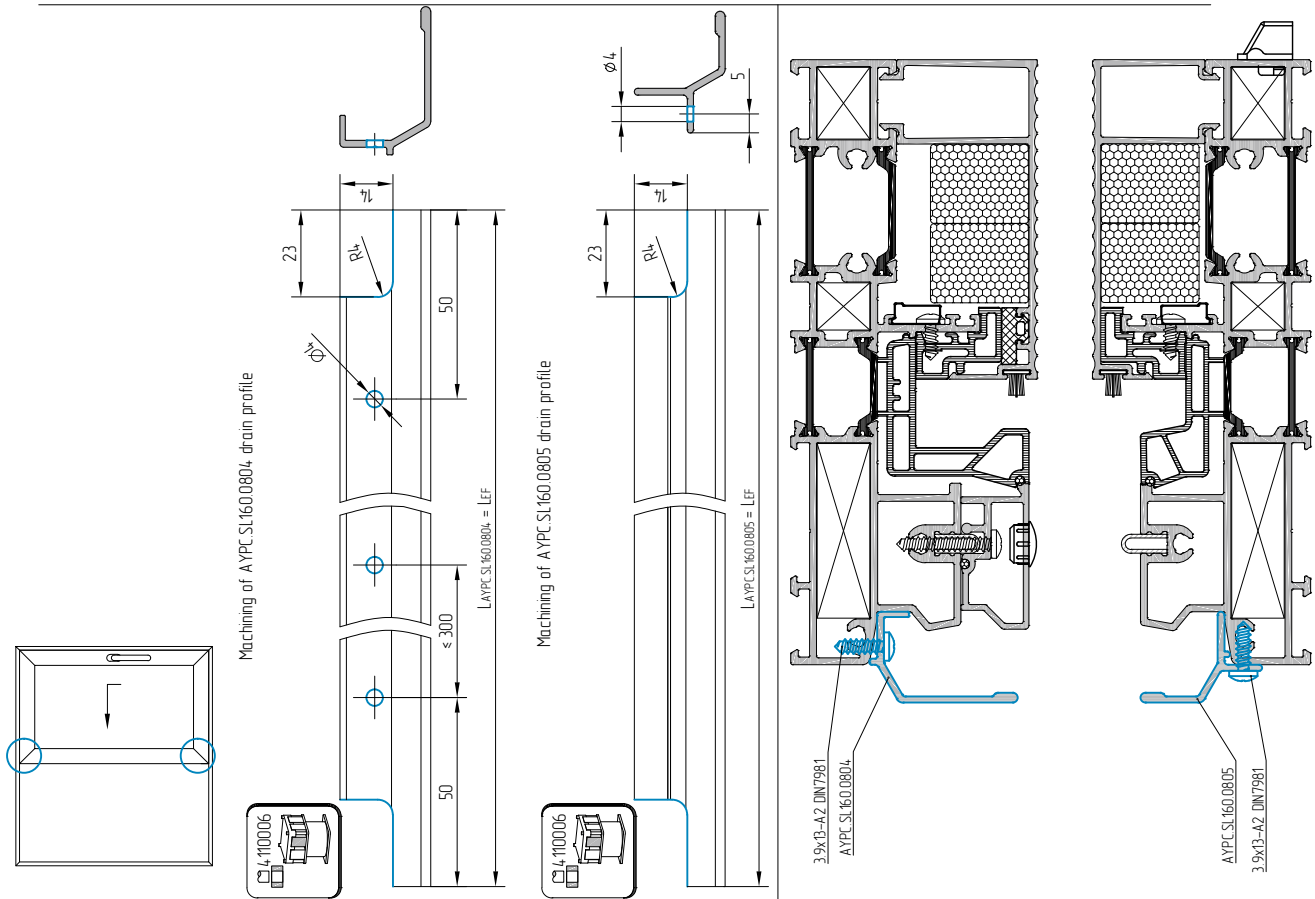

Machining and installation of AYPC.SL.160.0801 and AYPC.SL.160.0812 guide rail (top)

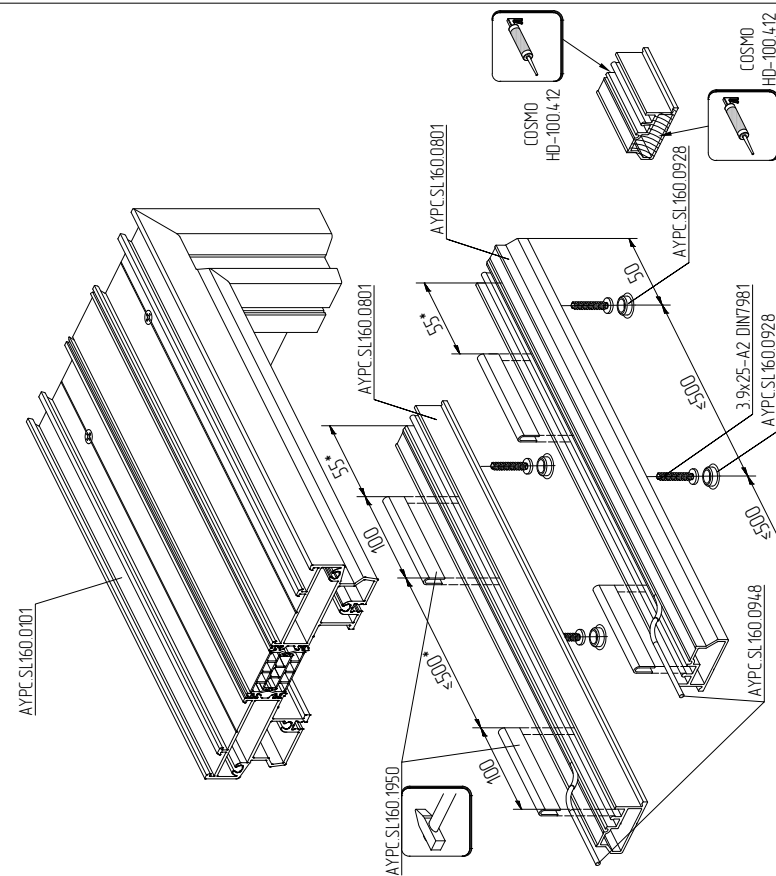
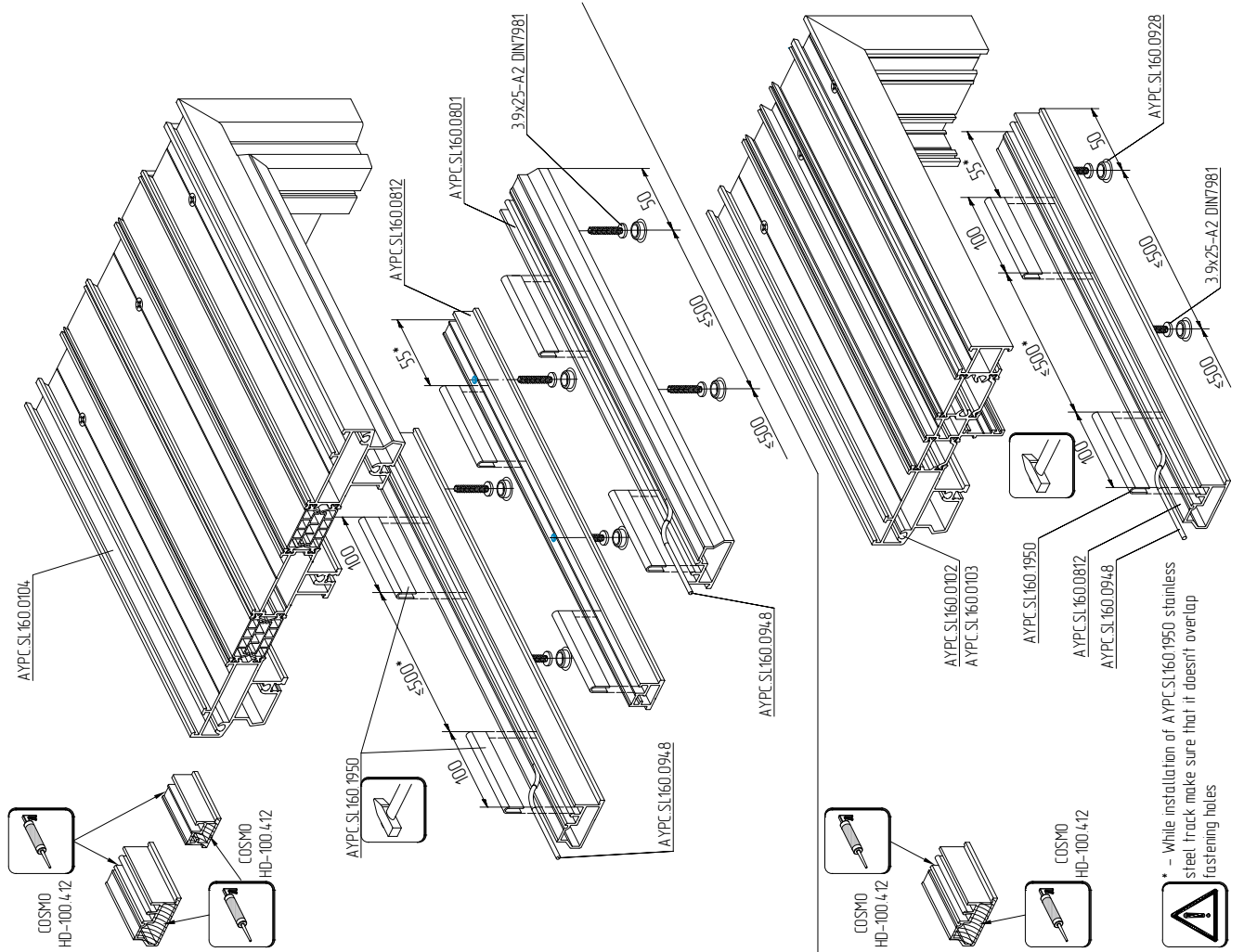

Machining of AYPC.SL.160.0801 guide rail (top)

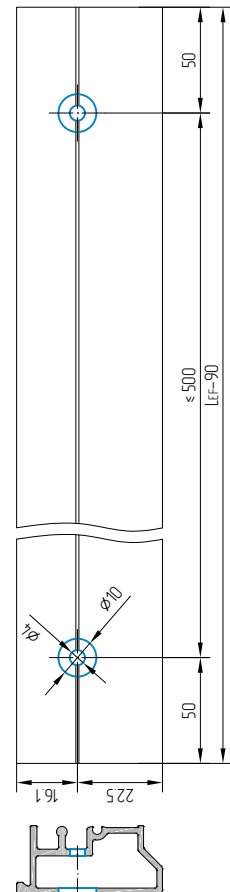

Machining of AYPC.SL.160.0812 guide rail (top)

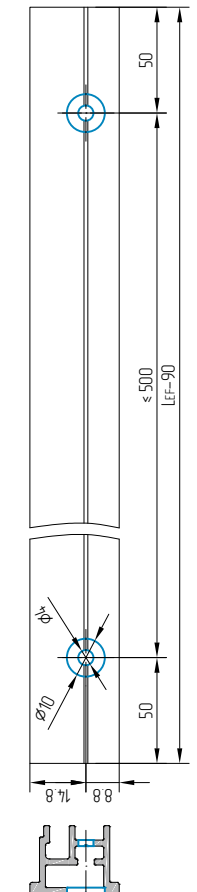

Installation of AYPC.SL.160.0941 and AYPC.SL.160.0942 upper ledge kit

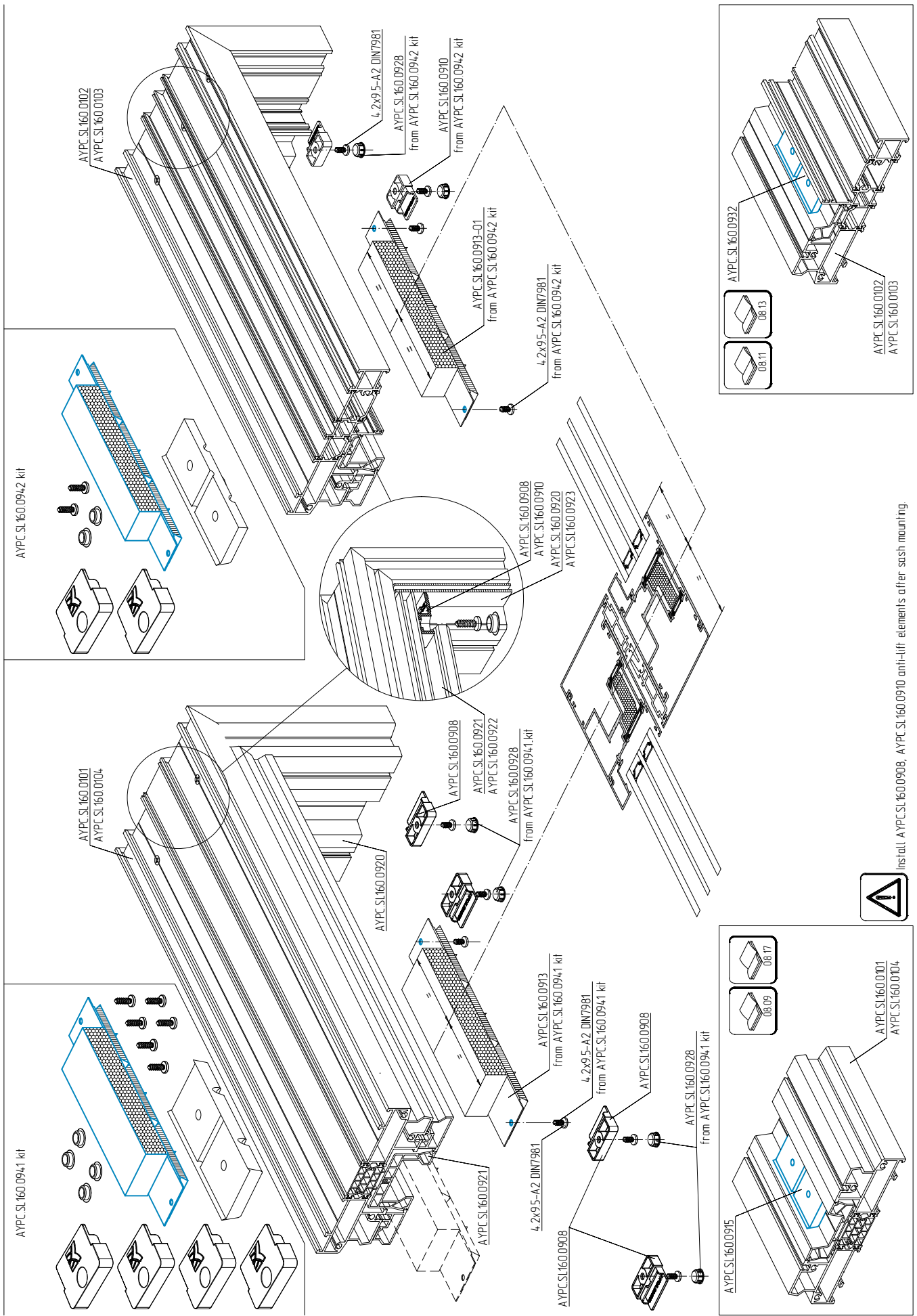

Install AYPC.SL.160.0908, AYPC.SL.160.0910 anti-lift elements after sash mounting

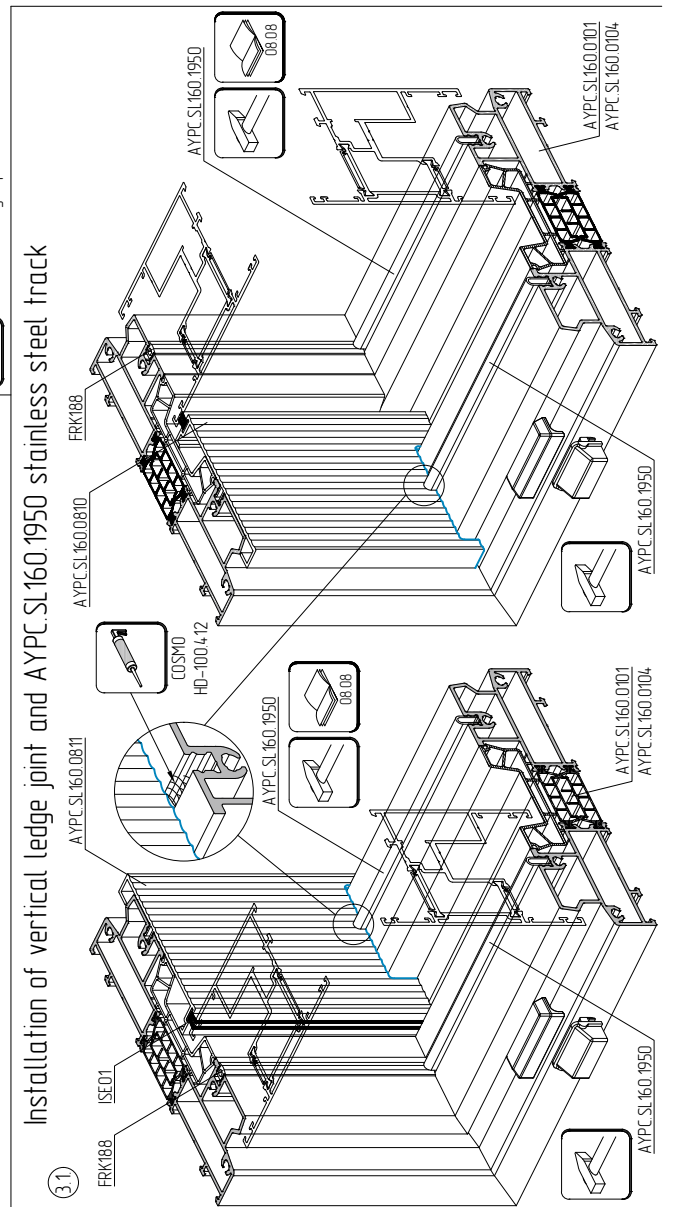
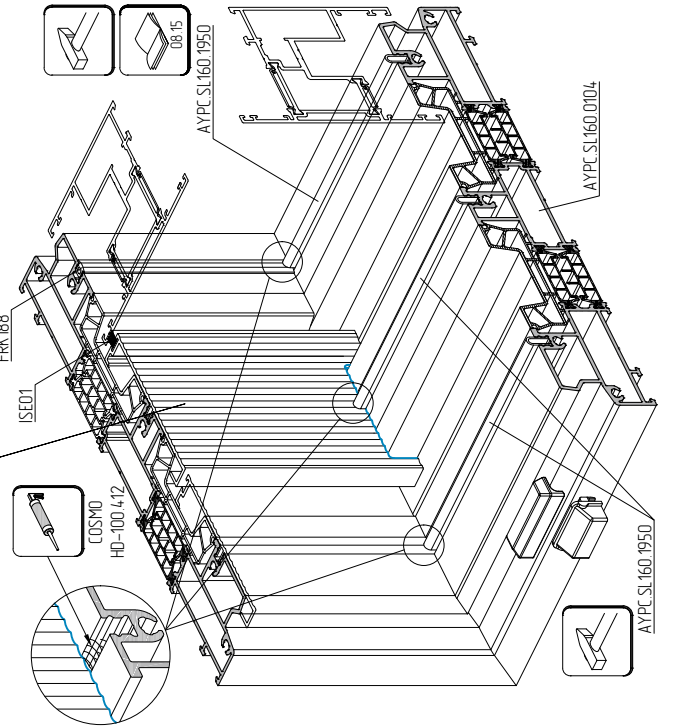
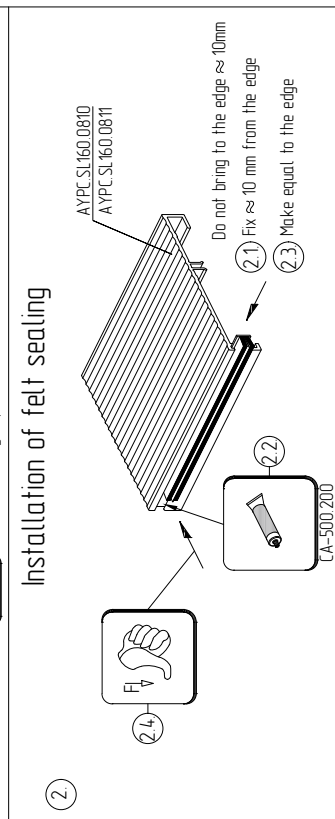
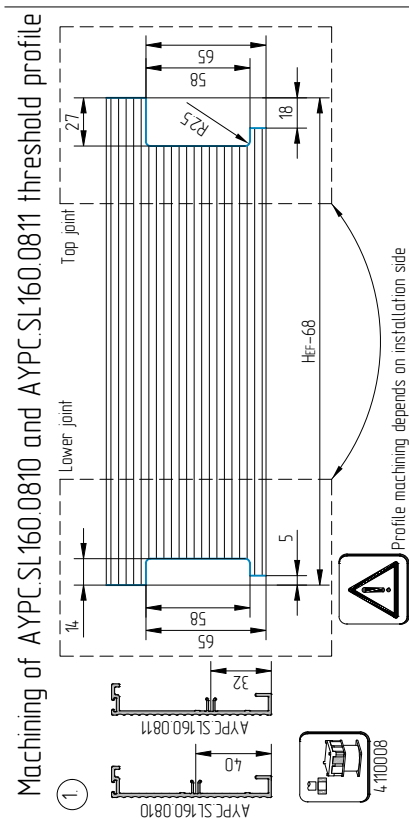
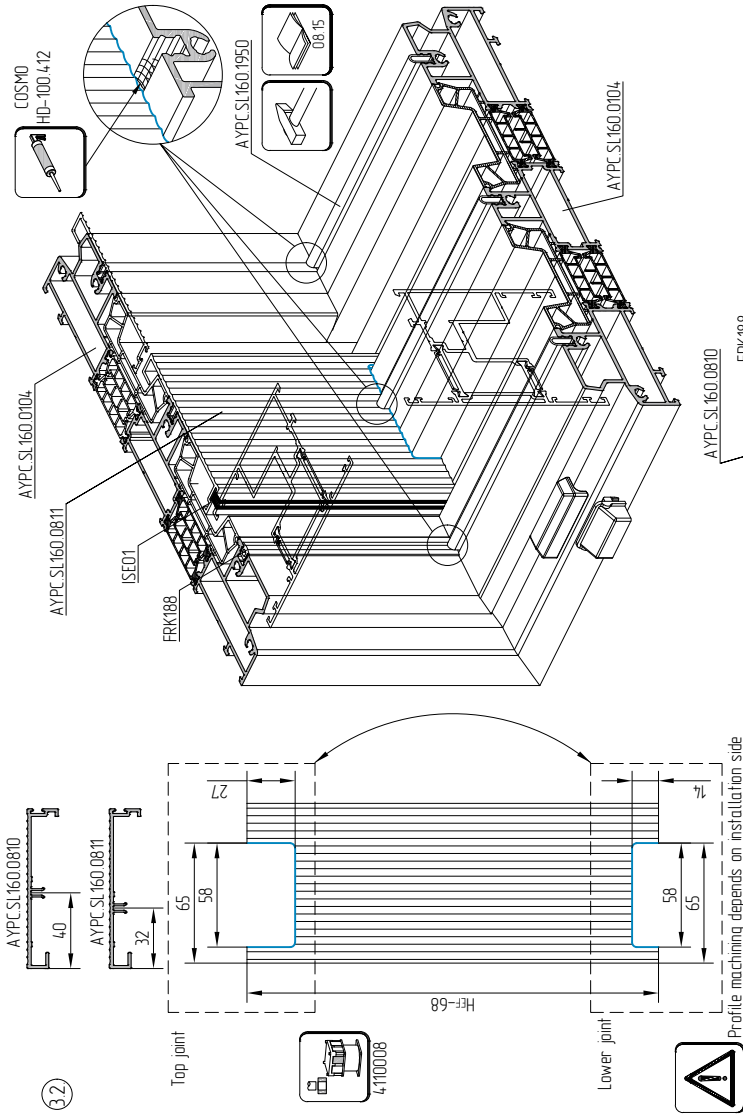

Machining of AYPC.SL160.0924 added profile and AYPC.SL160.0806 threshold profile

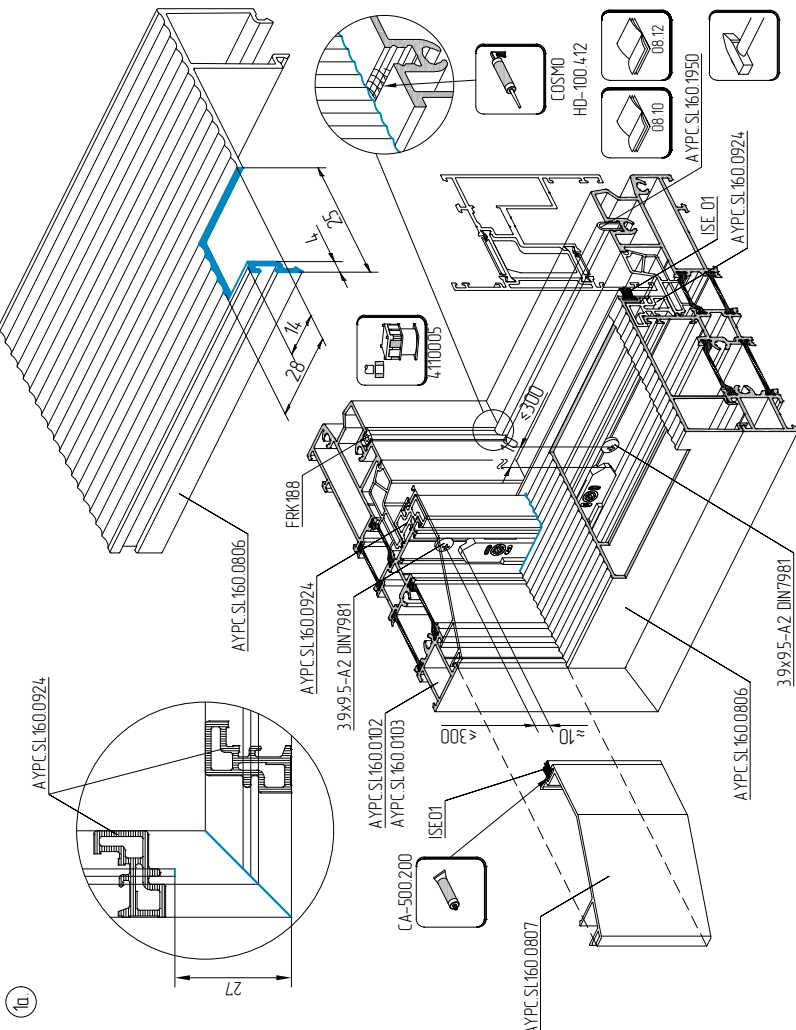

Installation of AYPC.SL160.0924 added profile and machining of AYPC.SL160.0808 threshold profile

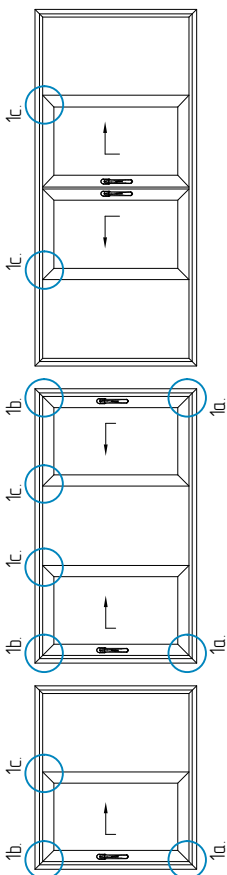
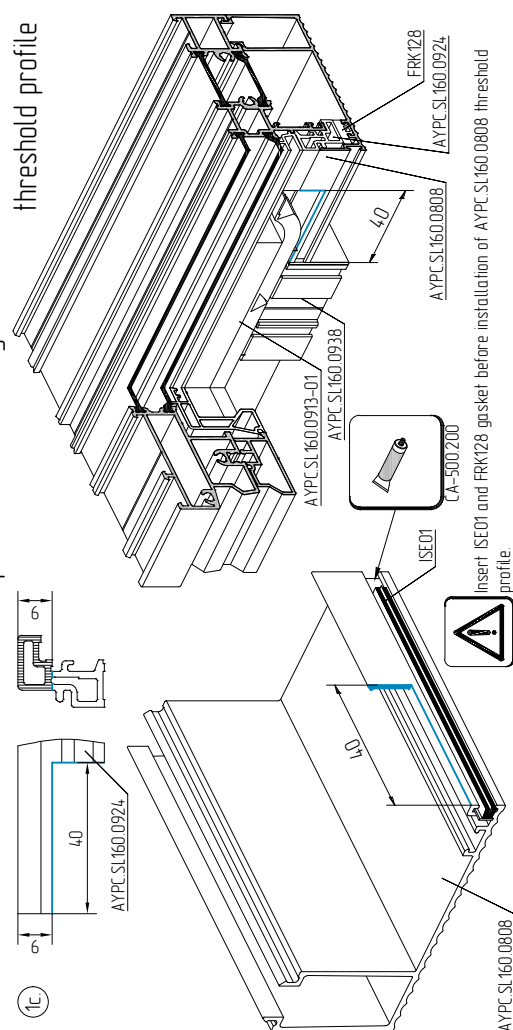

Machining of AYPC.SL160.0924 added profile and AYPC.SL160.0808 threshold profile

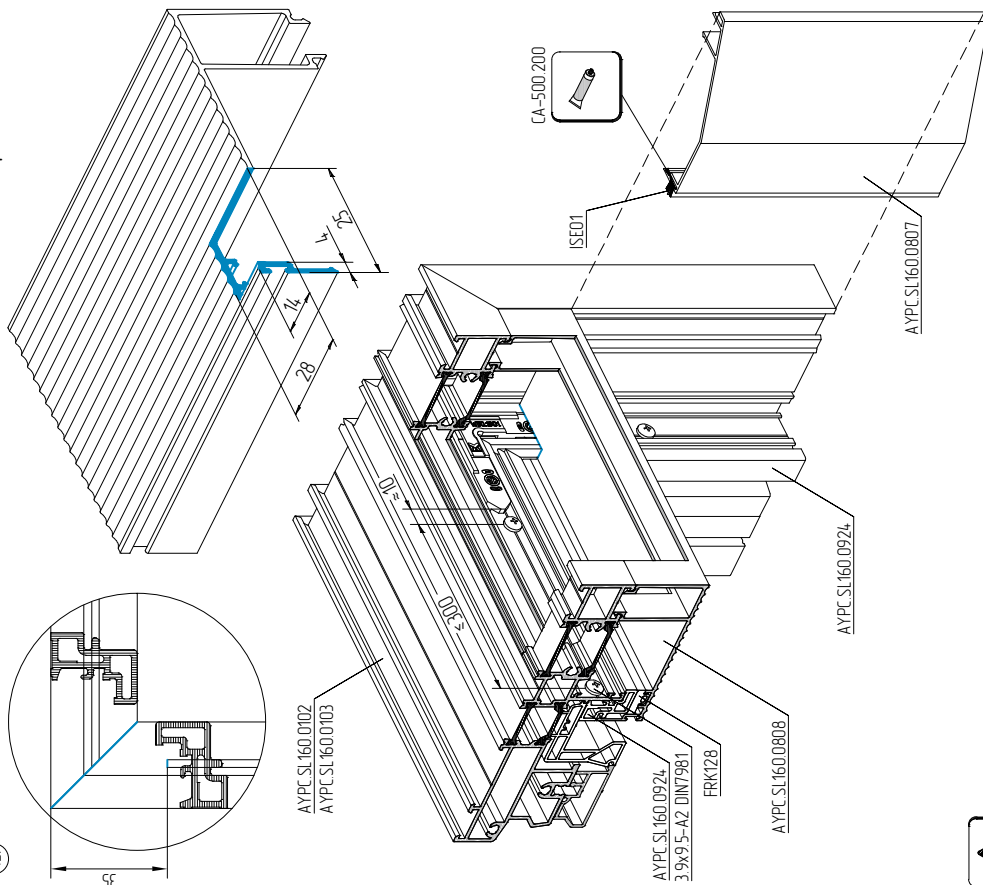

Insert ISE01 felt sealing before installation of AYPC.SL160.0808 threshold profile and AYPC.SL160.0807 slope profile

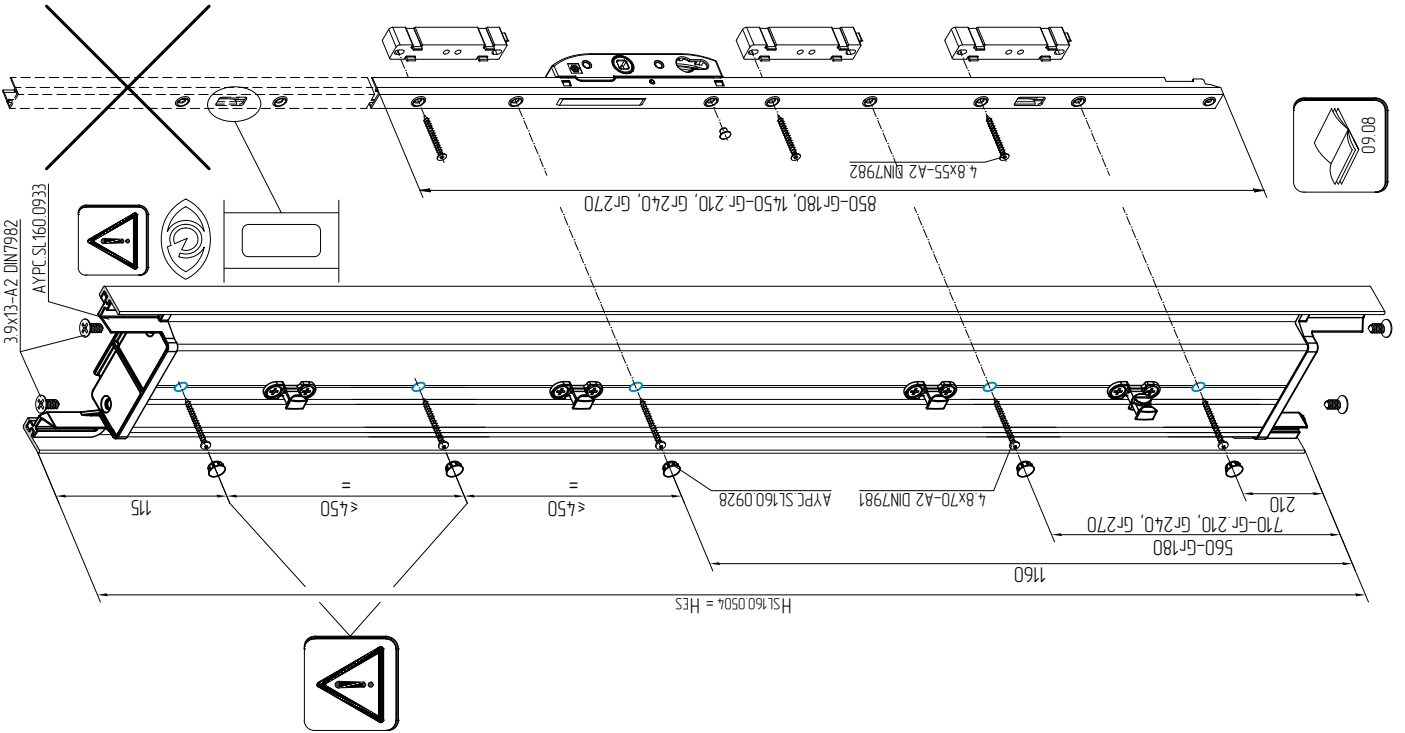

Basic machining and installation of AYPFC.SL160.0504 interlocking profile

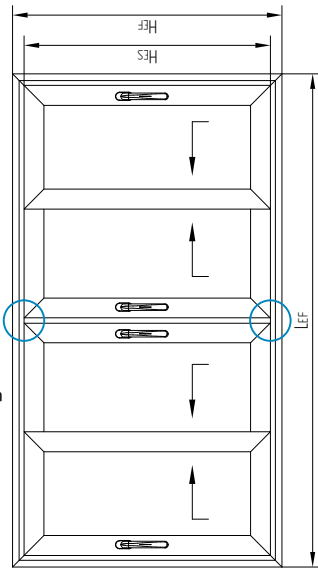

Before installation of AYPFC.SL160.0504 interlocking profile make sure that additional machining of interlocking profile was realized depending on the door configuration.

Machining of AYPFC.SL160.0504 interlocking profile

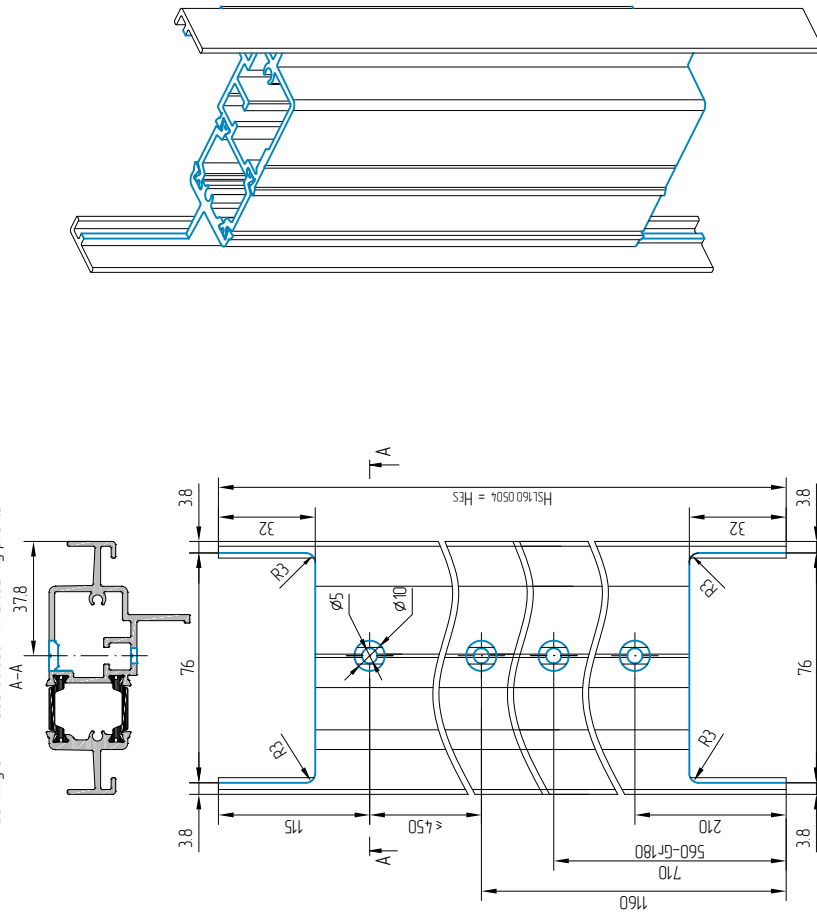

Make sure that interlocking profile fixing holes do not overlap locking points.

Additional machining of AYPC.SL160.0504 interlocking profile.
AYPC.SL160.0101, AYPC.SL160.0104 frame with AYPC.SL160.0810/AYPC.SL160.0811 threshold profile

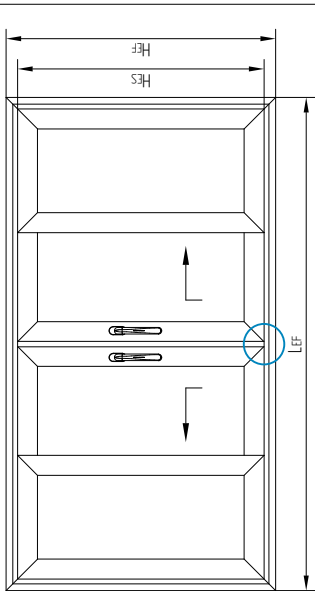

Machining of AYPC.SL160.0933 interlocking profile plug

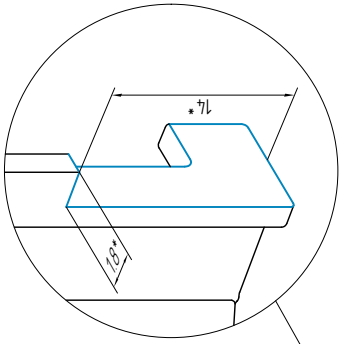
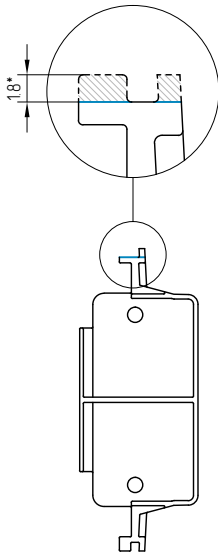

Additional machining of AYPC.SL160.0504 interlocking profile

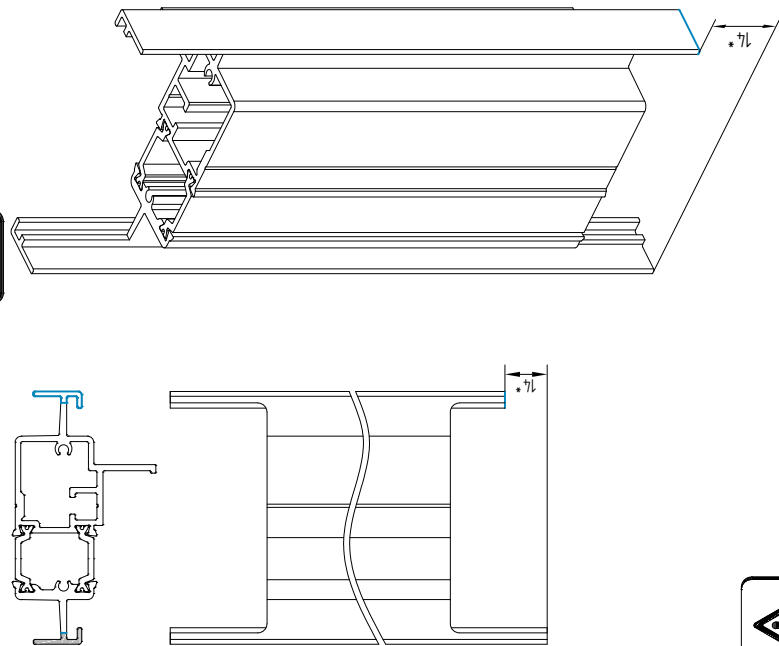

Installation example of AYPC.SL160.0504 interlocking profile

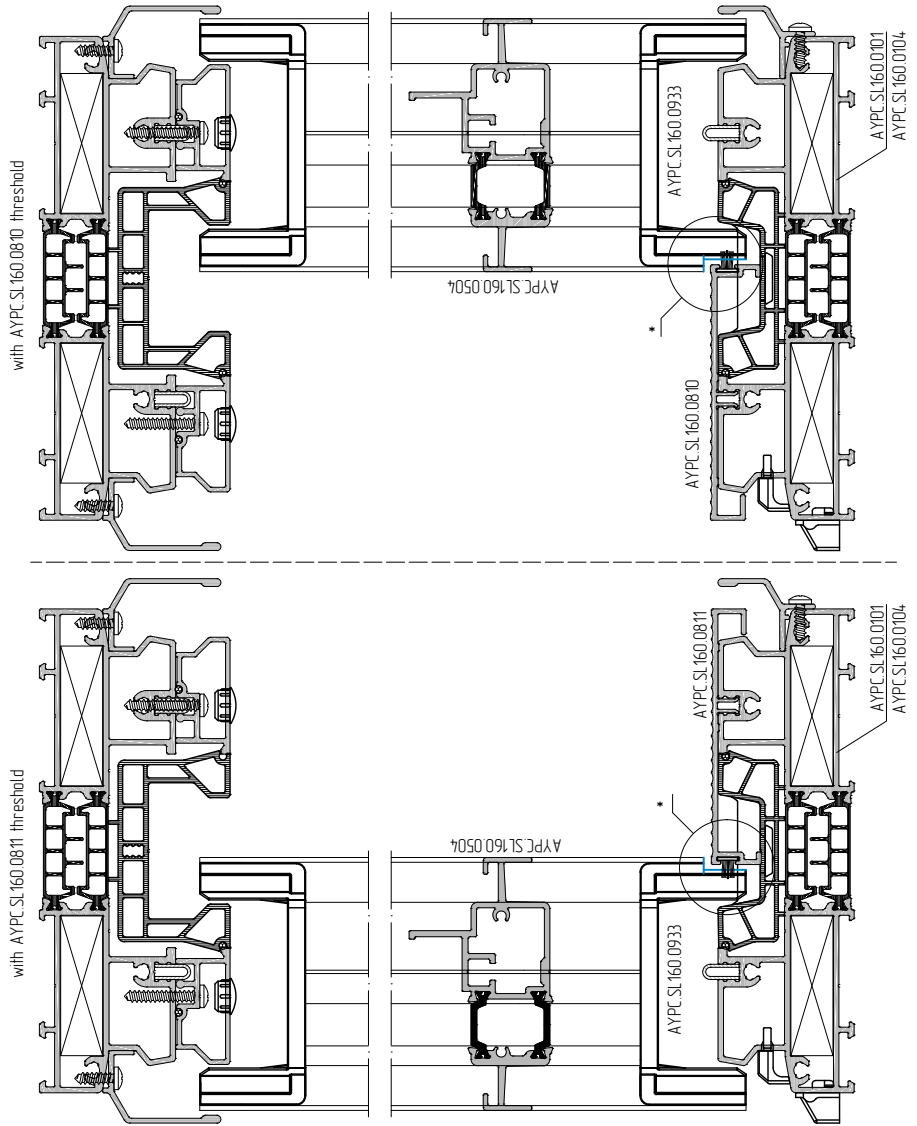

* - Do machining from the side of AYPC.SL160.0810 (AYPC.SL160.0811) threshold profile installation.

Additional machining of AYPC.SL160.0504 interlocking profile.

AYPC.SL160.0102, AYPC.SL160.0103 frame

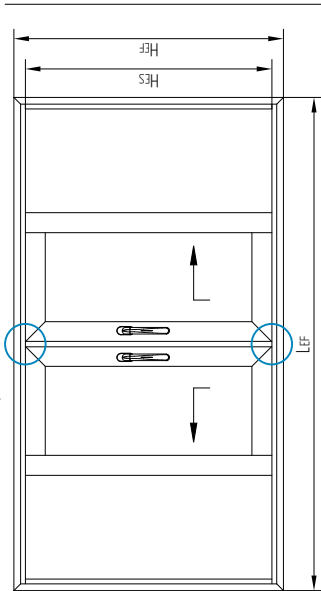

Machining of AYPC.SL160.0933 interlocking profile plug

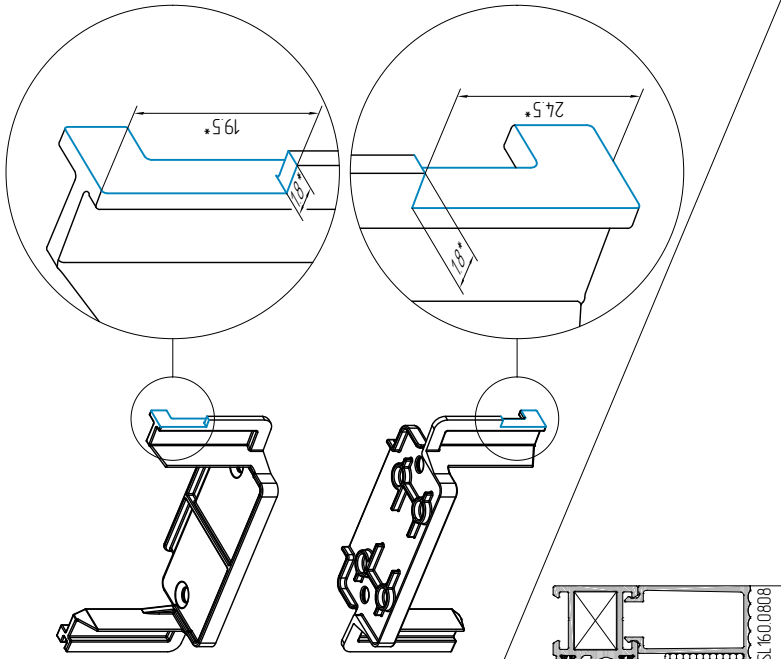
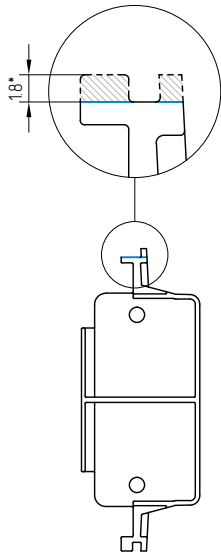

Additional machining of AYPC.SL160.0504 interlocking profile

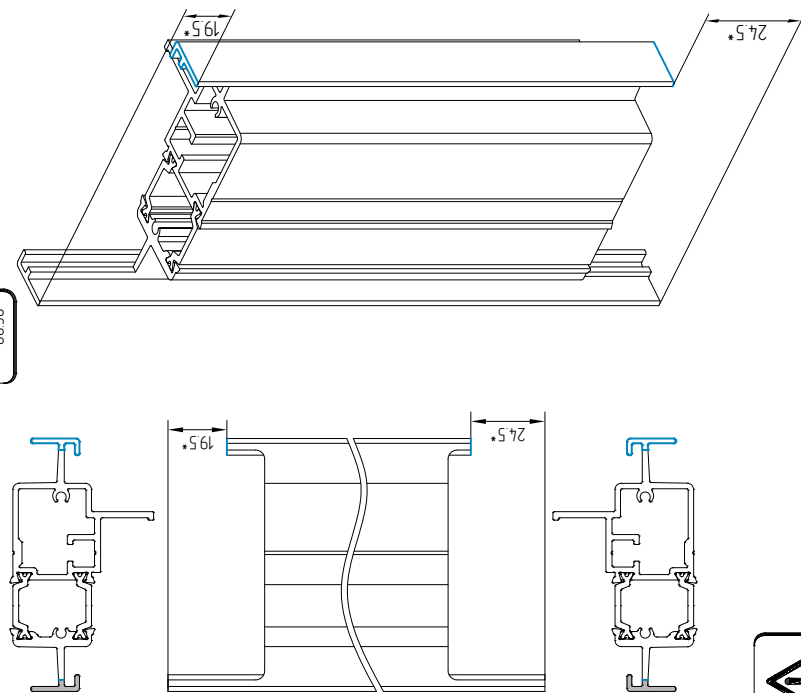

Installation example of AYPC.SL160.0504 interlocking profile

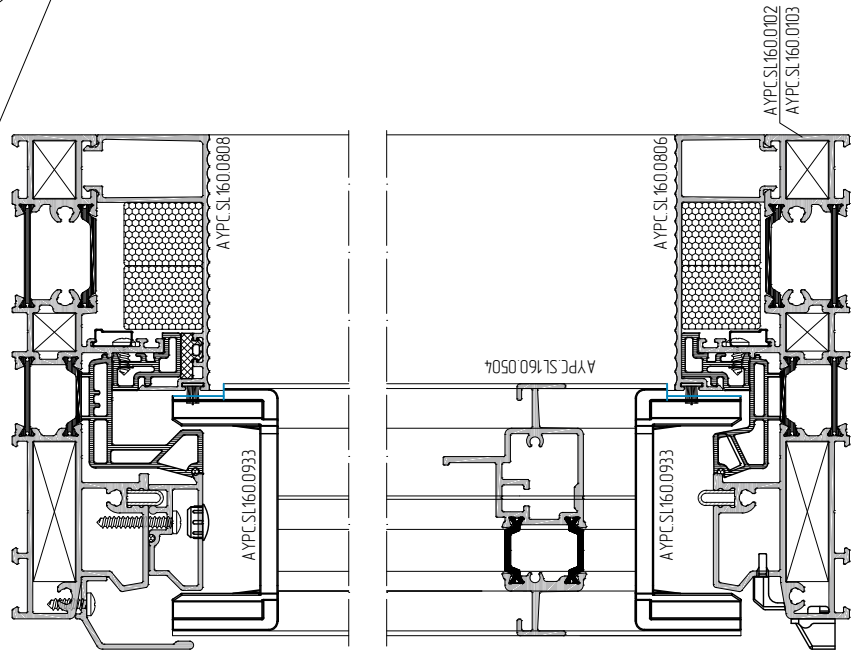

* -Do machining from the side of AYPC.SL160.0810 (AYPC.SL160.0811) threshold profile installation.



Machining and installation plan of AYPC.SL160.0701, AYPC.SL160.0702 and AYPC.C43.0706 reinforcing profiles

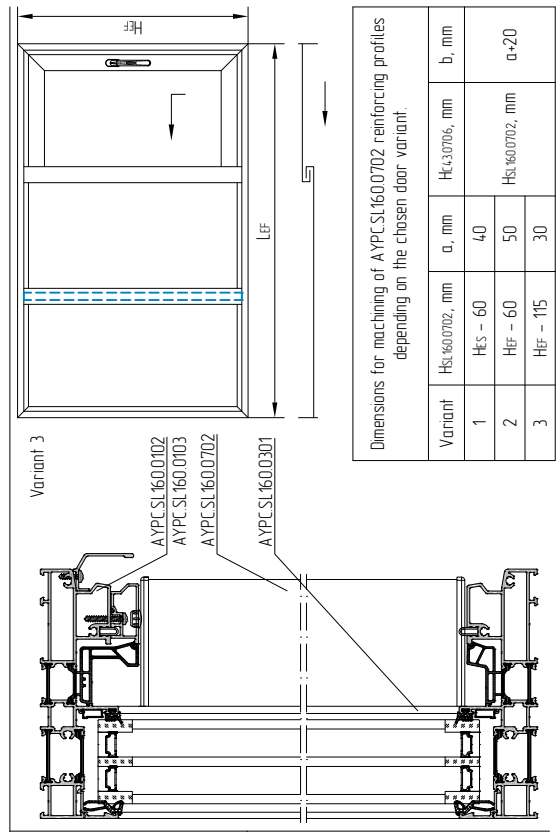
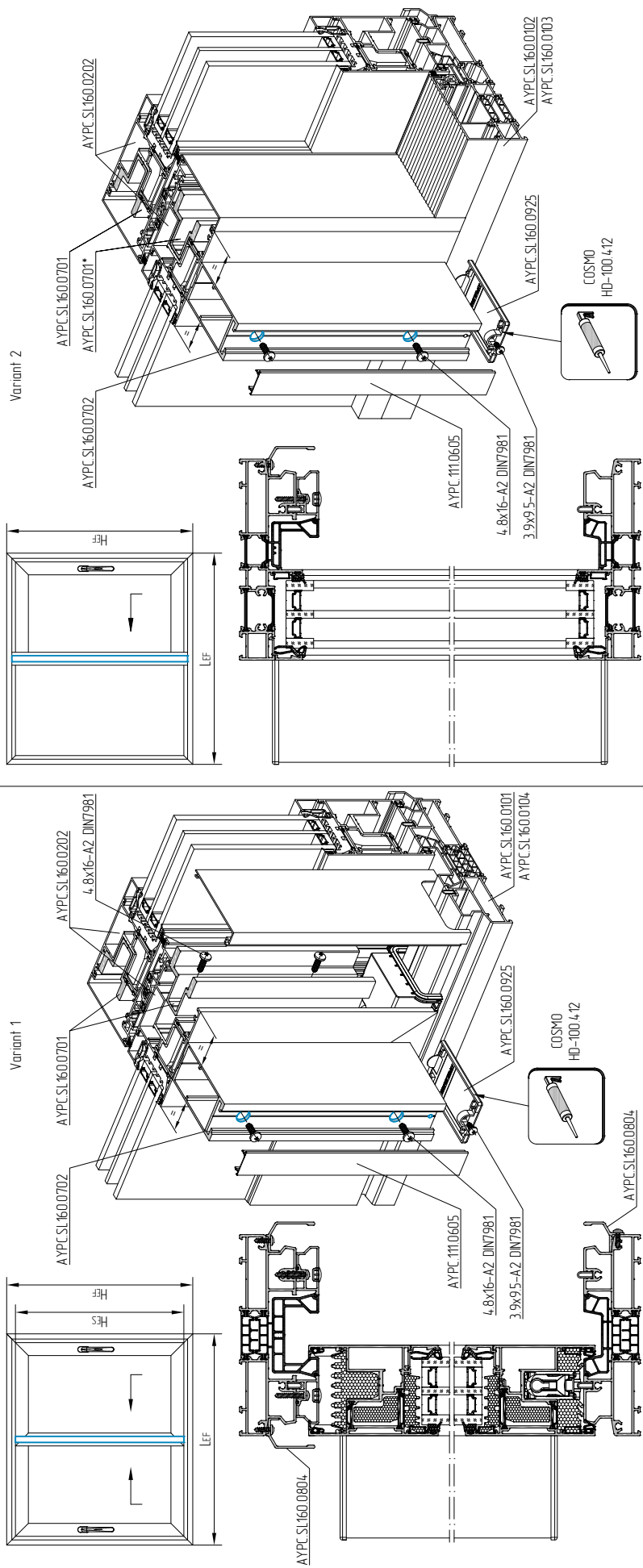

Dimensions for machining of AYPC.SL160.0702 reinforcing profiles depending on the chosen door variant.

Variant	Hs160702, mm	a, mm	b, mm
1	Hs - 60	40	a-20
2	Hs - 60	50	Hs160702, mm
3	Hs - 115	30	

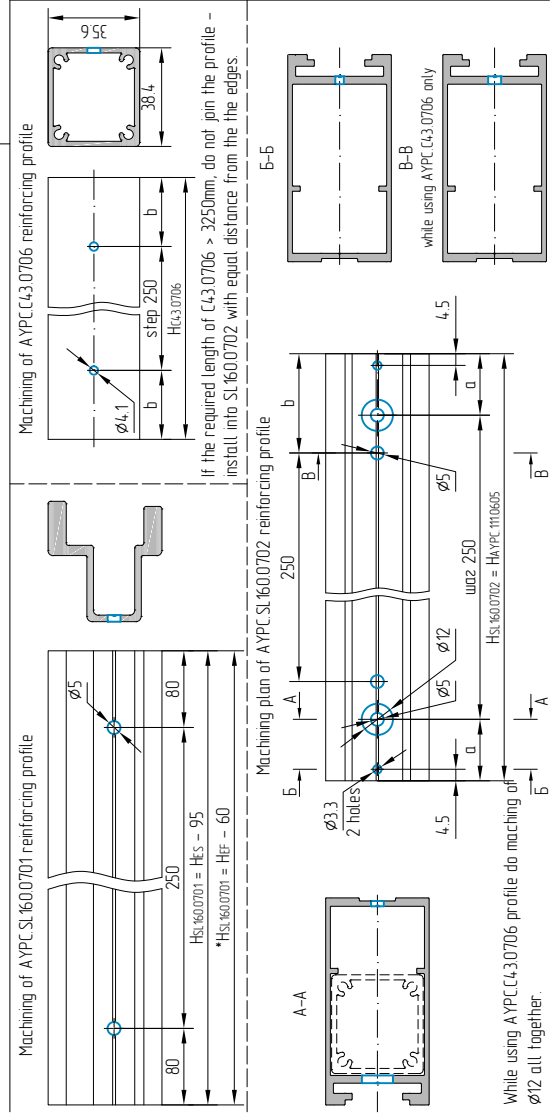

Machining of AYPC.SL160.0501 adapter

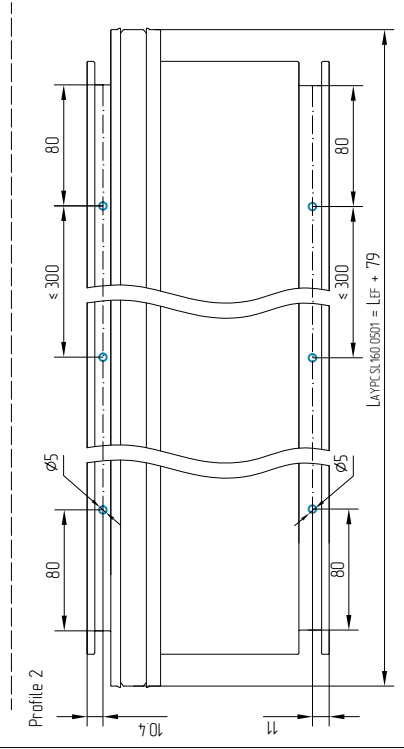
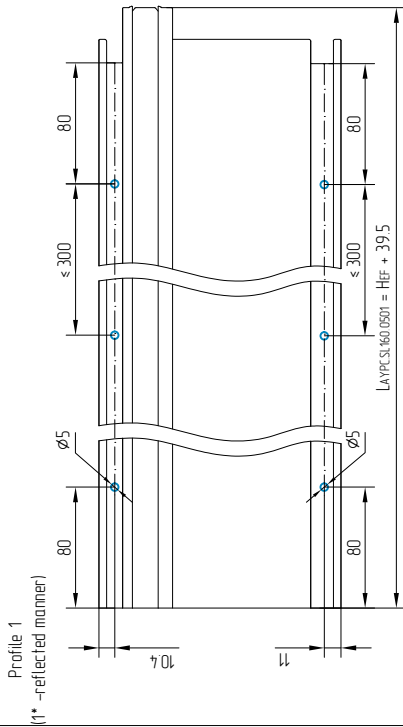

Machining of AYPC.SL160.0501 adapter and frame profile for 4.8x16-A2 DIN7981 self-tapping screws installation

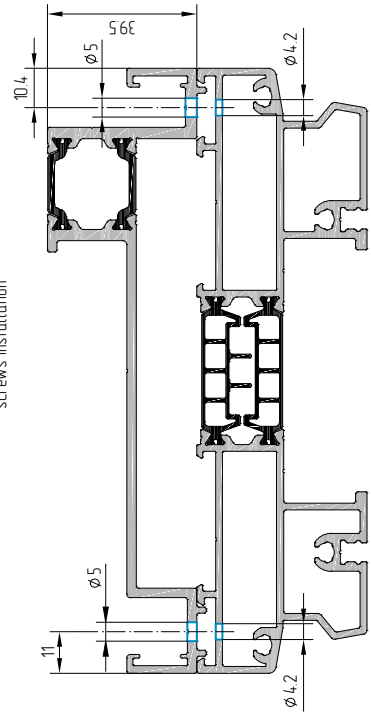

Machining and assemblage of AYPC.SL160.0501 adapter

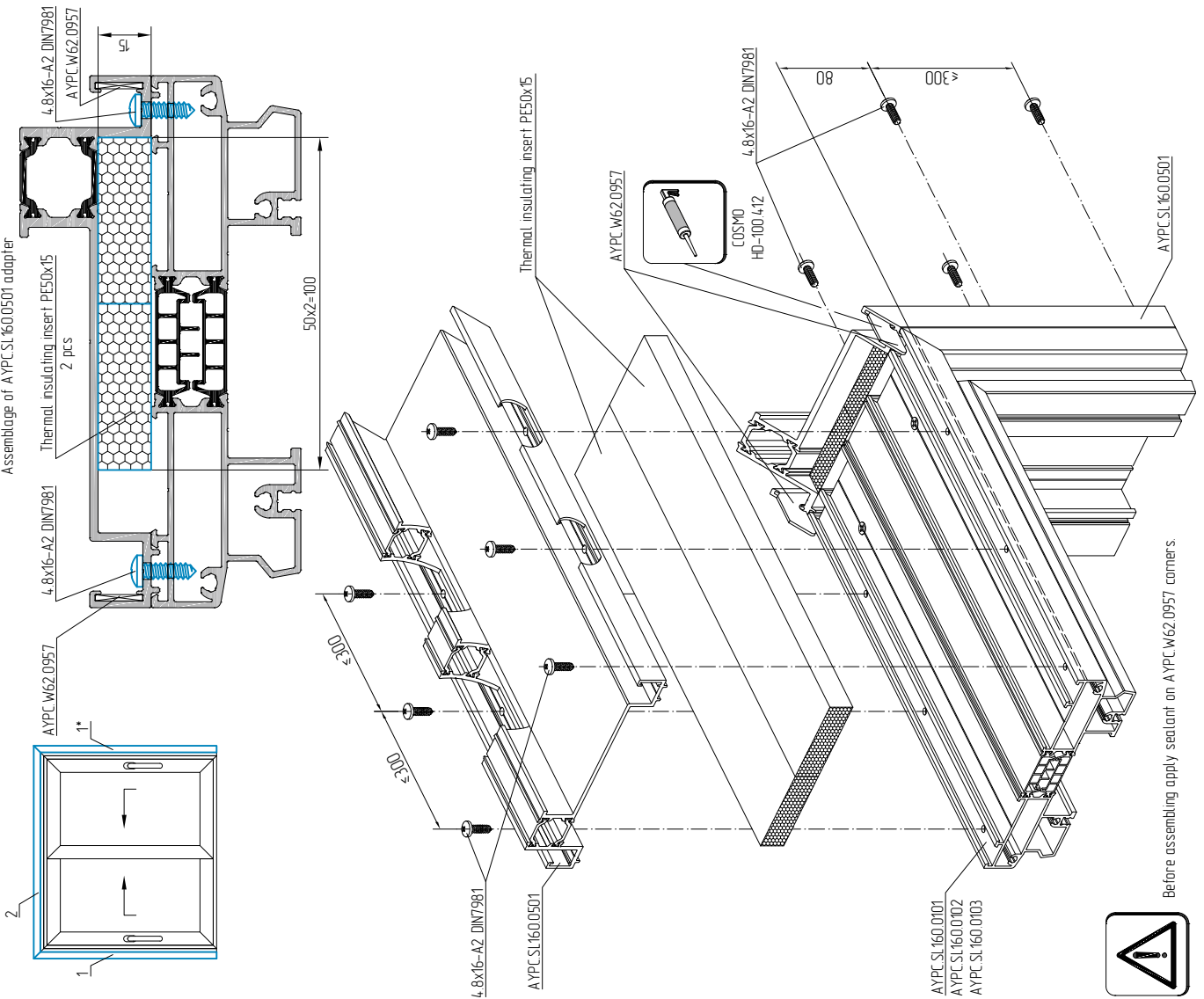

Before assembling apply sealant on AYPC.W62.0957 corners.

Glass installation into lift and slide door. Step 1

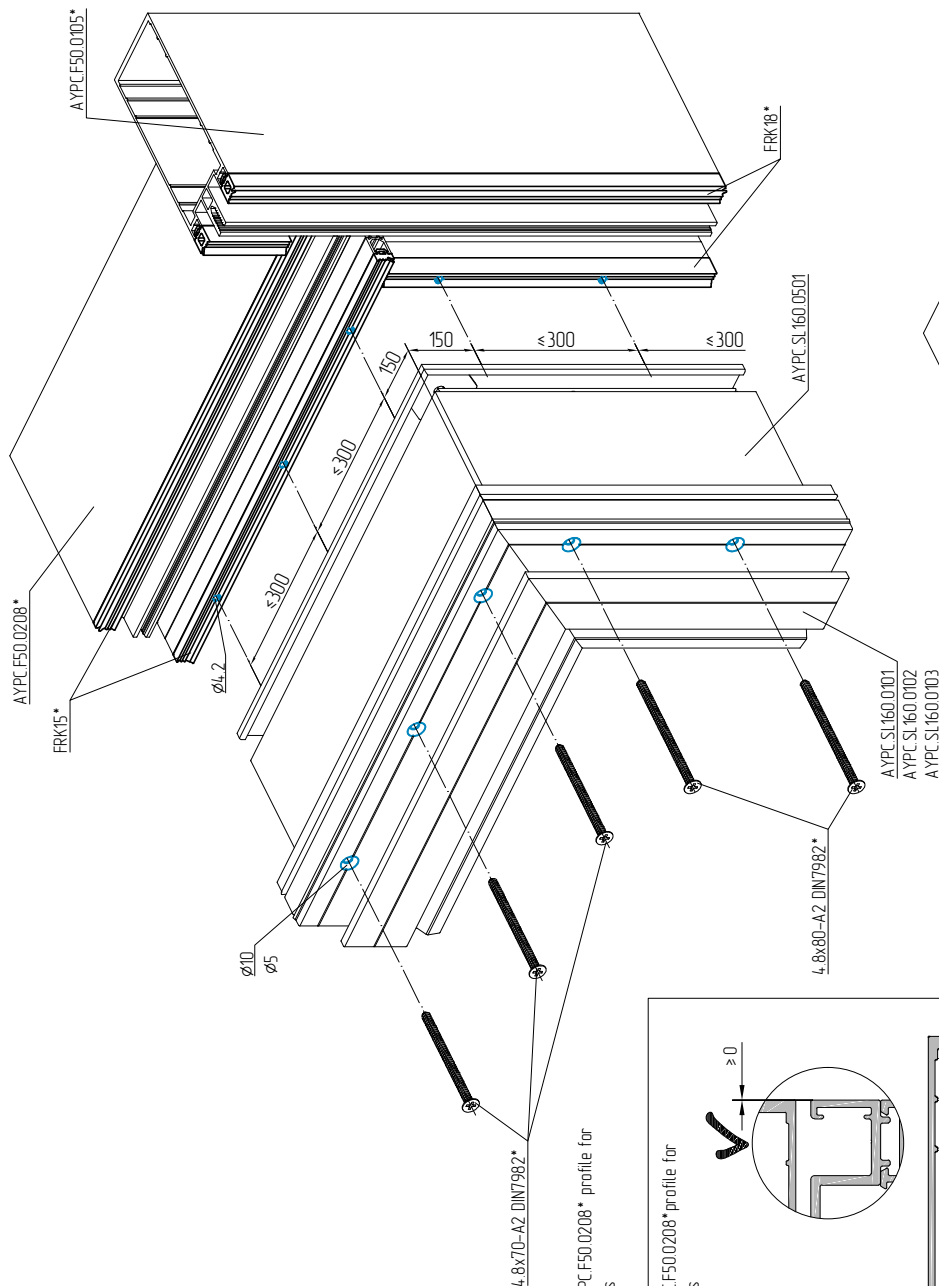
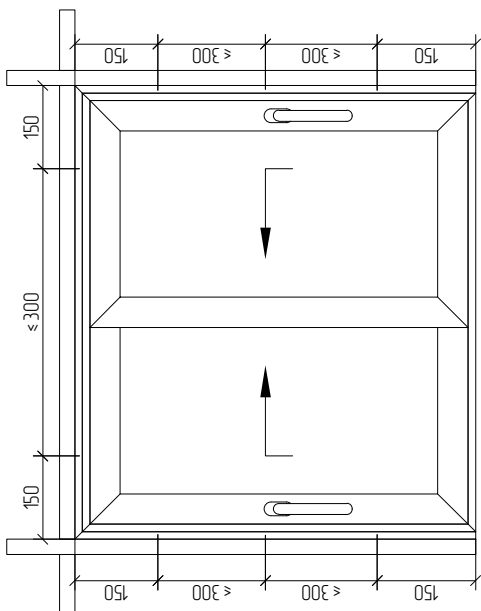

Machining plan of AYPCL160.0501 adapter and AYPCL160.0102/AYPCL160.0103 profile for 4.8x70(A2) DIN7982* self-tapping screws

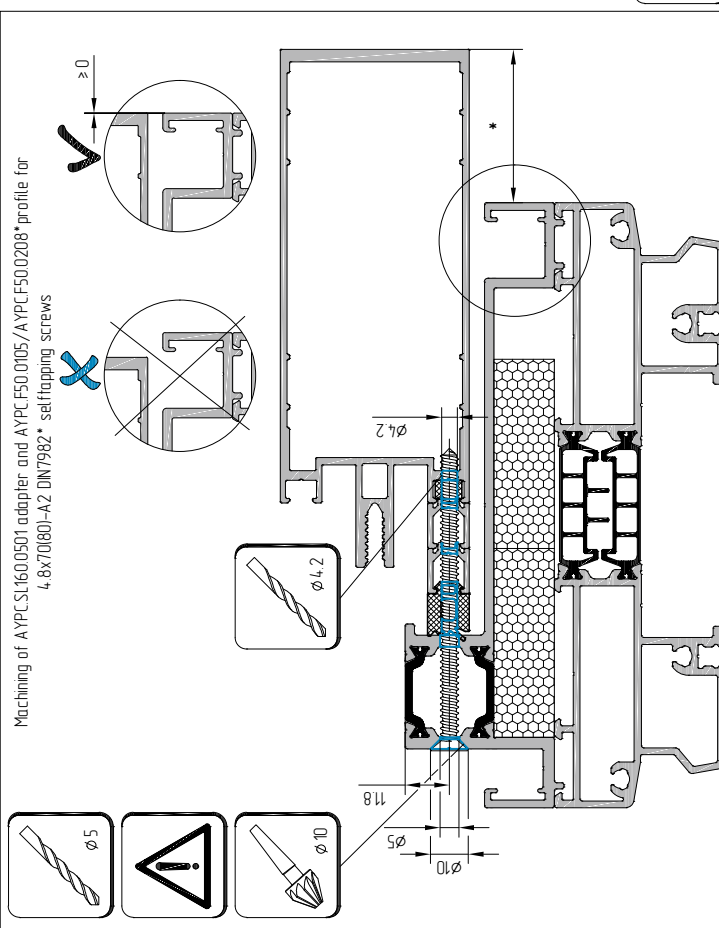

* - Information concerning the application of mullion/transom profiles, sealant and screws for lift and slide door depending on the thickness of infill unit find on pages 05.03-05.04.
Information concerning facade elements is provided in ALU F50 technical manual.

Glass installation into lift and slide door. Step 2

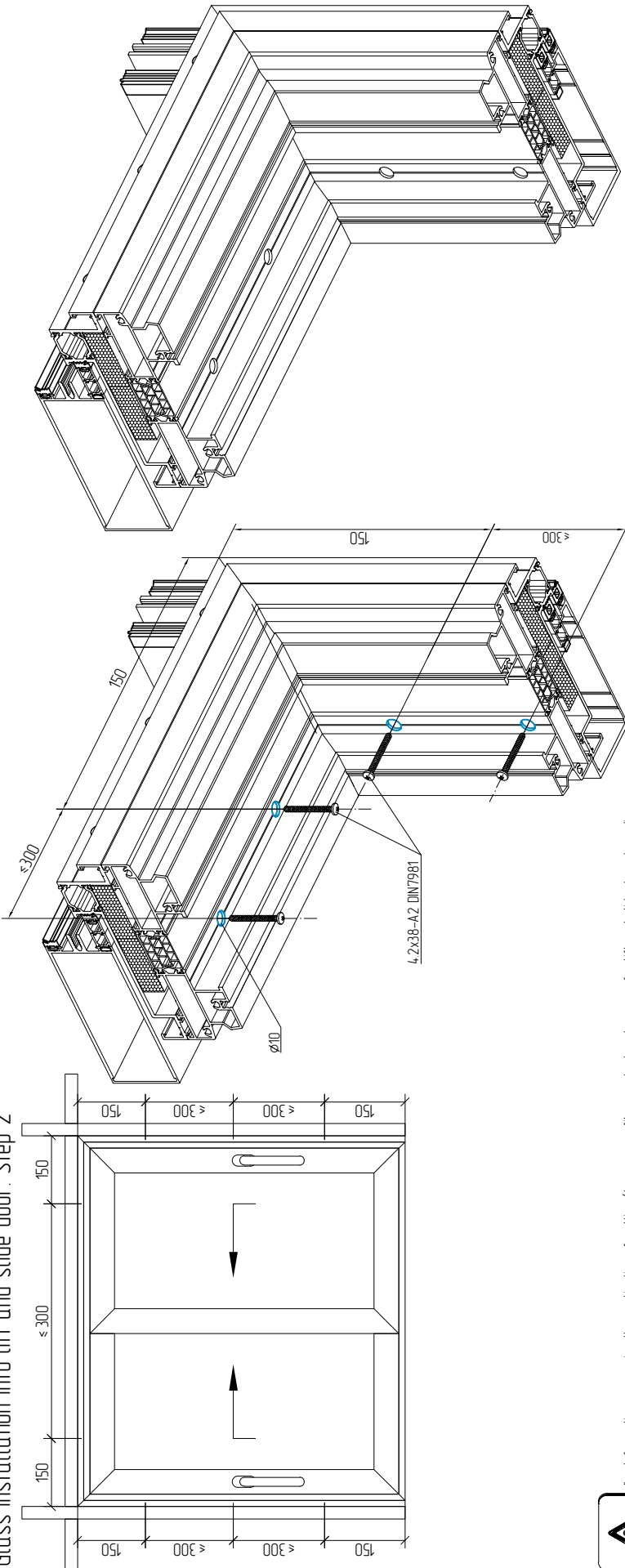

* - Information concerning the application of mullion/transom profiles, sealant and screws for lift and slide door depending on the thickness of infill unit find on pages 05-03-05-04. Data on facade joint elements is provided in ALT F50 catalogue.

Installation of 4.2x38-A2 DIN7981 self-tapping screws

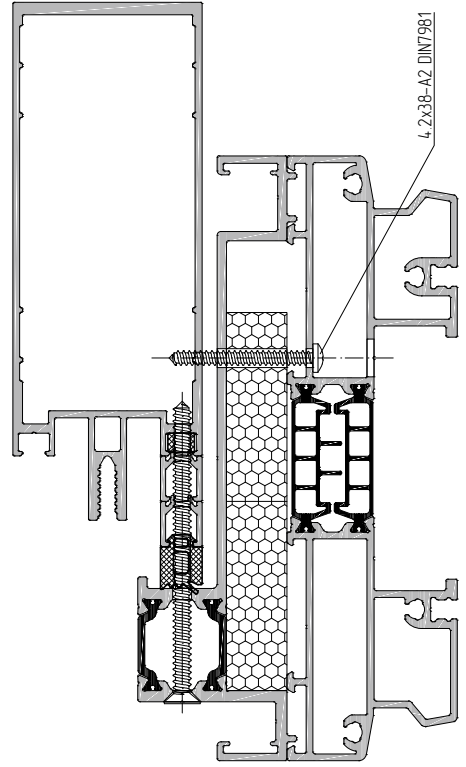

Machining of AYPC SL160.0501 adapter and AYPC.F50.0105/AYPC.F50.0208* profile for 4.2x38-A2 DIN7981 self-tapping screws

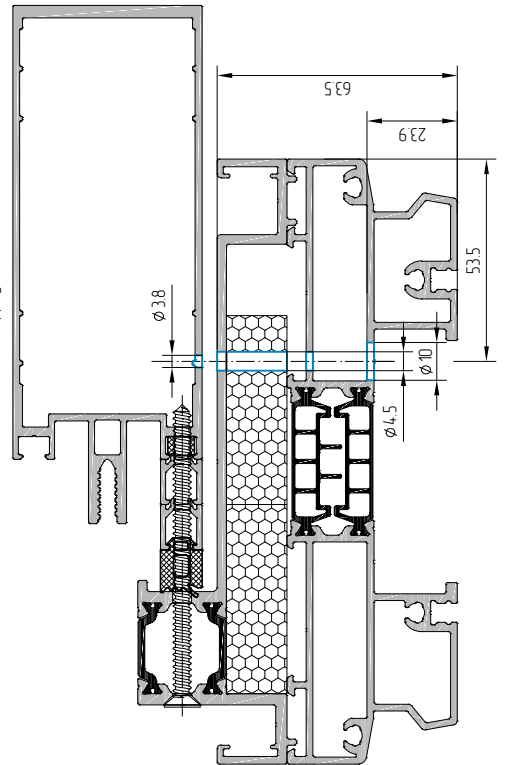

Assemblage of AYPC.SI.160.0505 adapter and AYPC.SI.160.0101/AYPC.SI.160.0102 frame profile

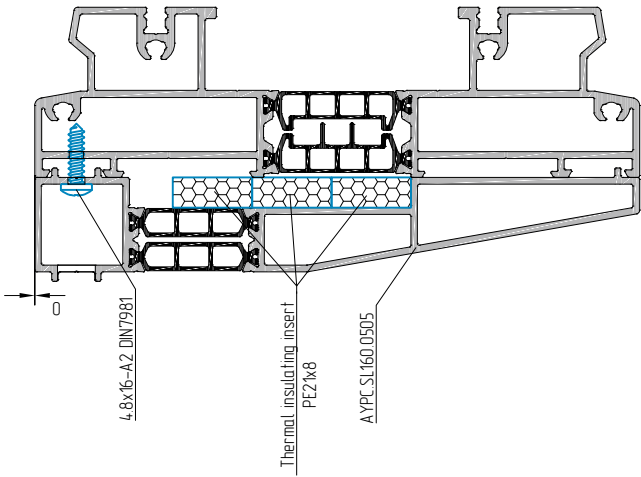

Machining of AYPC.SI.160.0505 adapter and AYPC.SI.160.0101/AYPC.SI.160.0103 frame profile

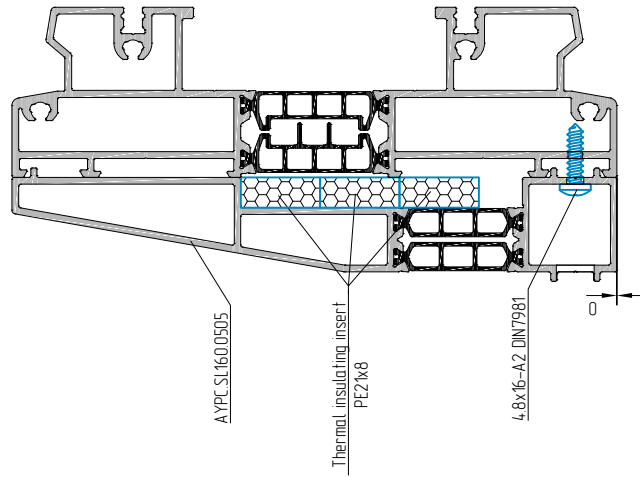

Machining of AYPC.SI.160.0505 adapter and AYPC.SI.160.0101/AYPC.SI.160.0102 frame profile for 4.8x16-A2 DIN7981 self-tapping screws

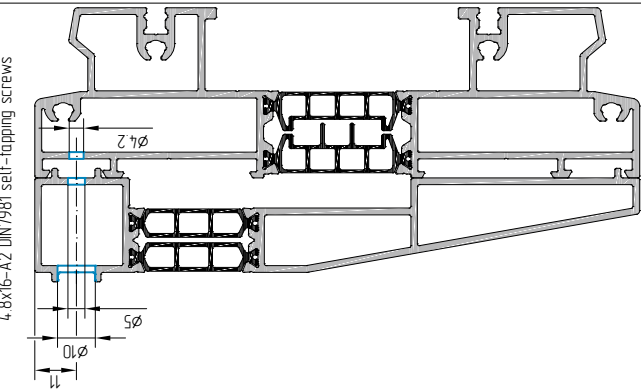

Machining of AYPC.SI.160.0505 adapter and AYPC.SI.160.0101/AYPC.SI.160.0103 frame profile for 4.8x16-A2 DIN7981 self-tapping screws

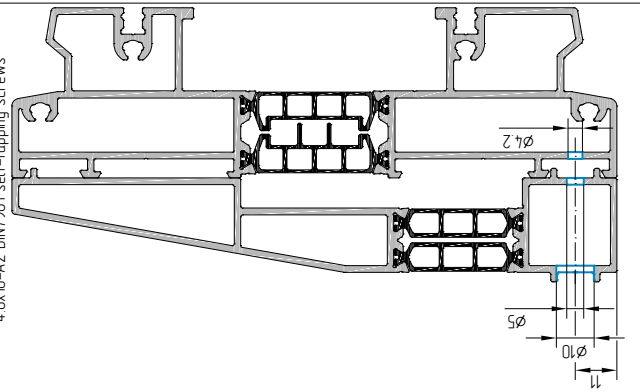

Integration of lift and slide door with W62/W72. Step 1

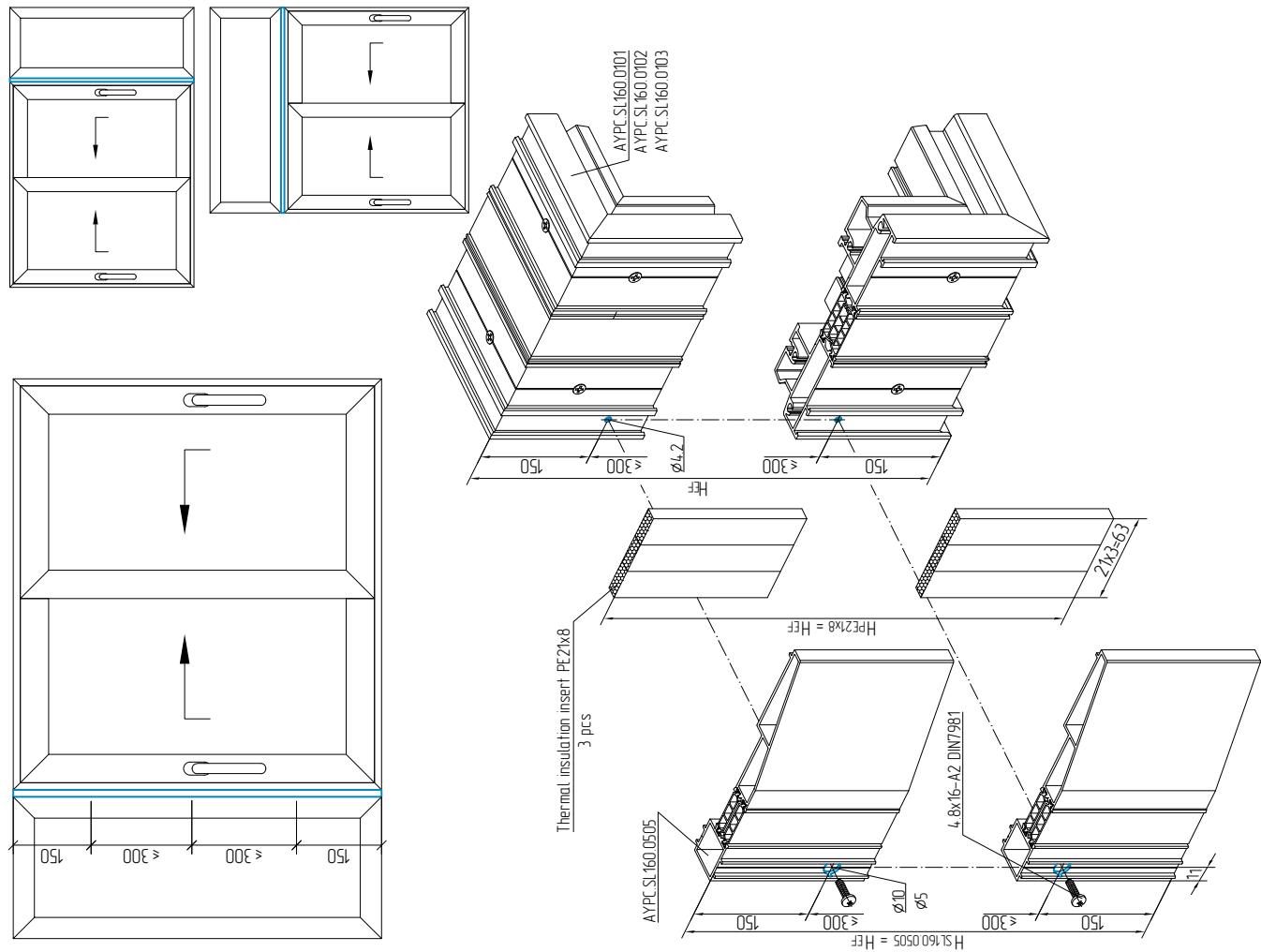

Machining of AYPCL160.0505 adapter and AYPCL160.0101/AYPCSL160.0102 frame profile

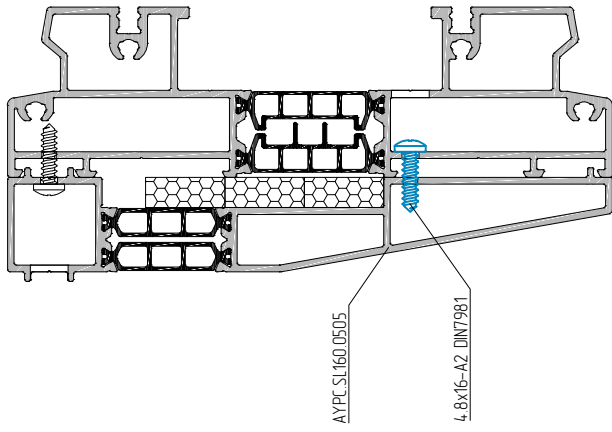

Machining of AYPCL160.0505 adapter and AYPCL160.0101/AYPCSL160.0103 frame profile

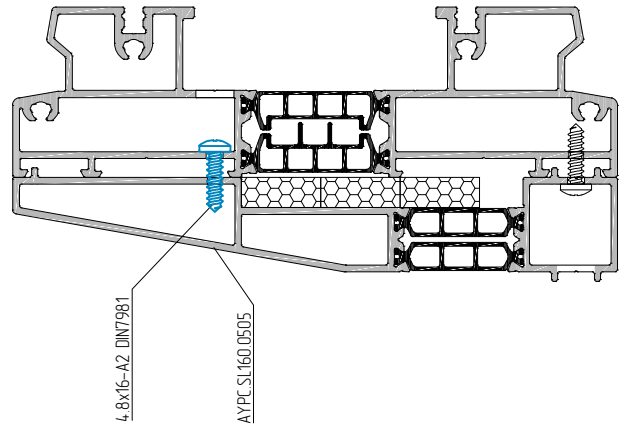

Machining of AYPCL160.0505 adapter and AYPCL160.0101/AYPCSL160.0102 frame profile for 4.8x16-A2 DIN7981 self-tapping screws

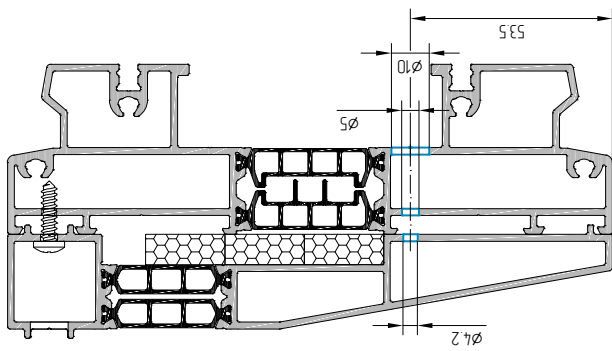

Machining of AYPCL160.0505 adapter and AYPCL160.0101/AYPCSL160.0103 frame profiles for 4.8x16-A2 DIN7981 self-tapping screws

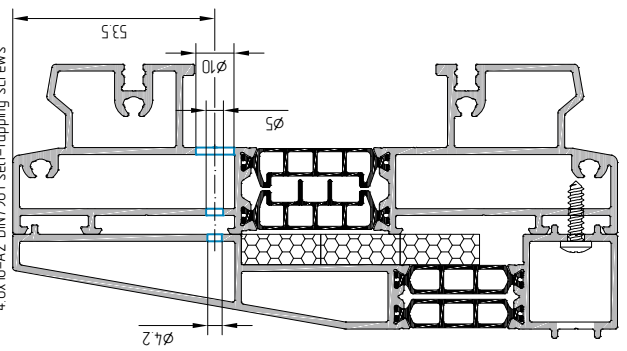

Integration of lift and slide door with W62/W72. Step 2

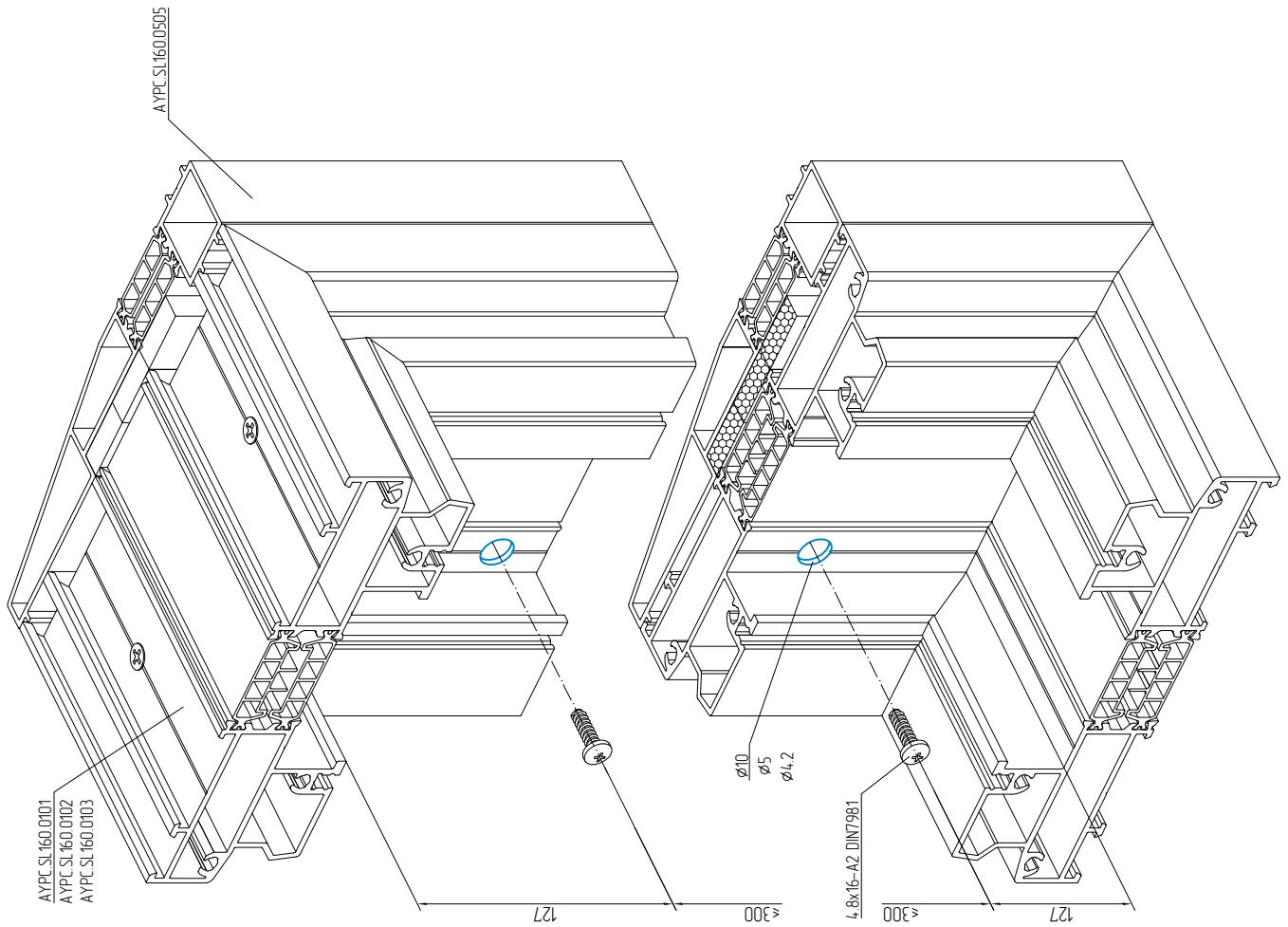

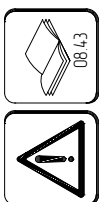
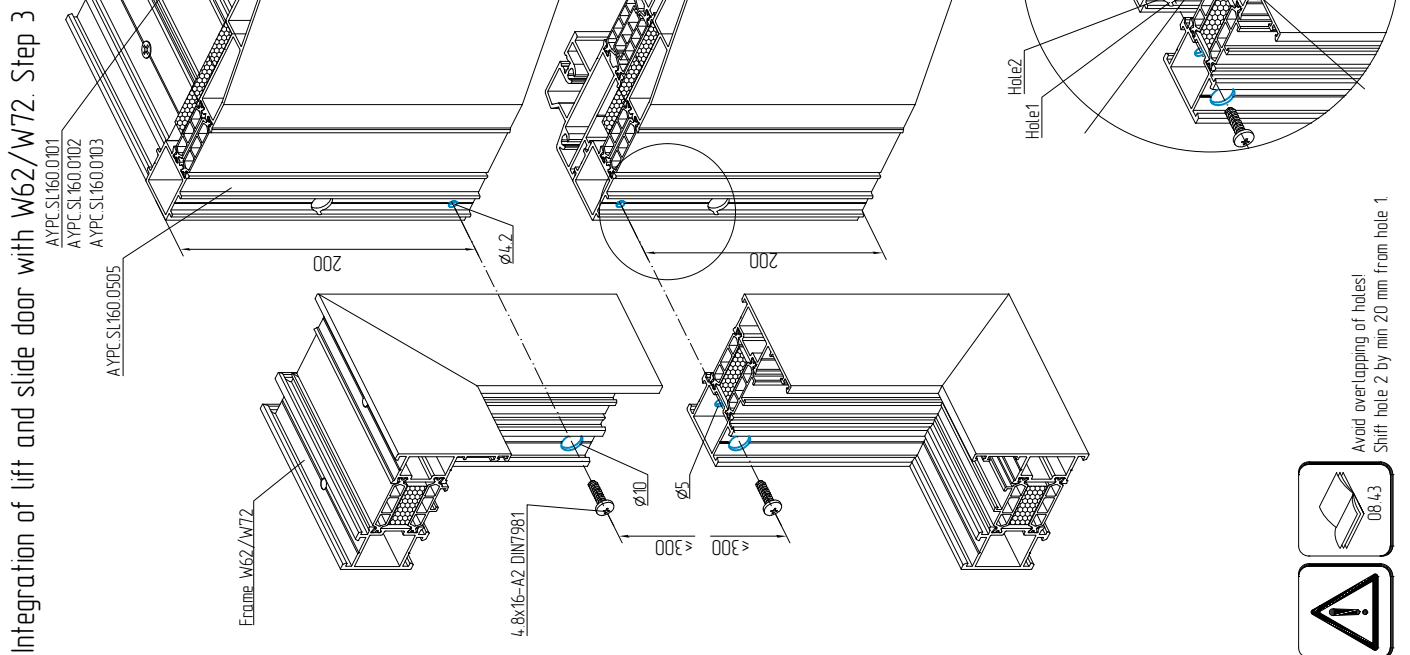
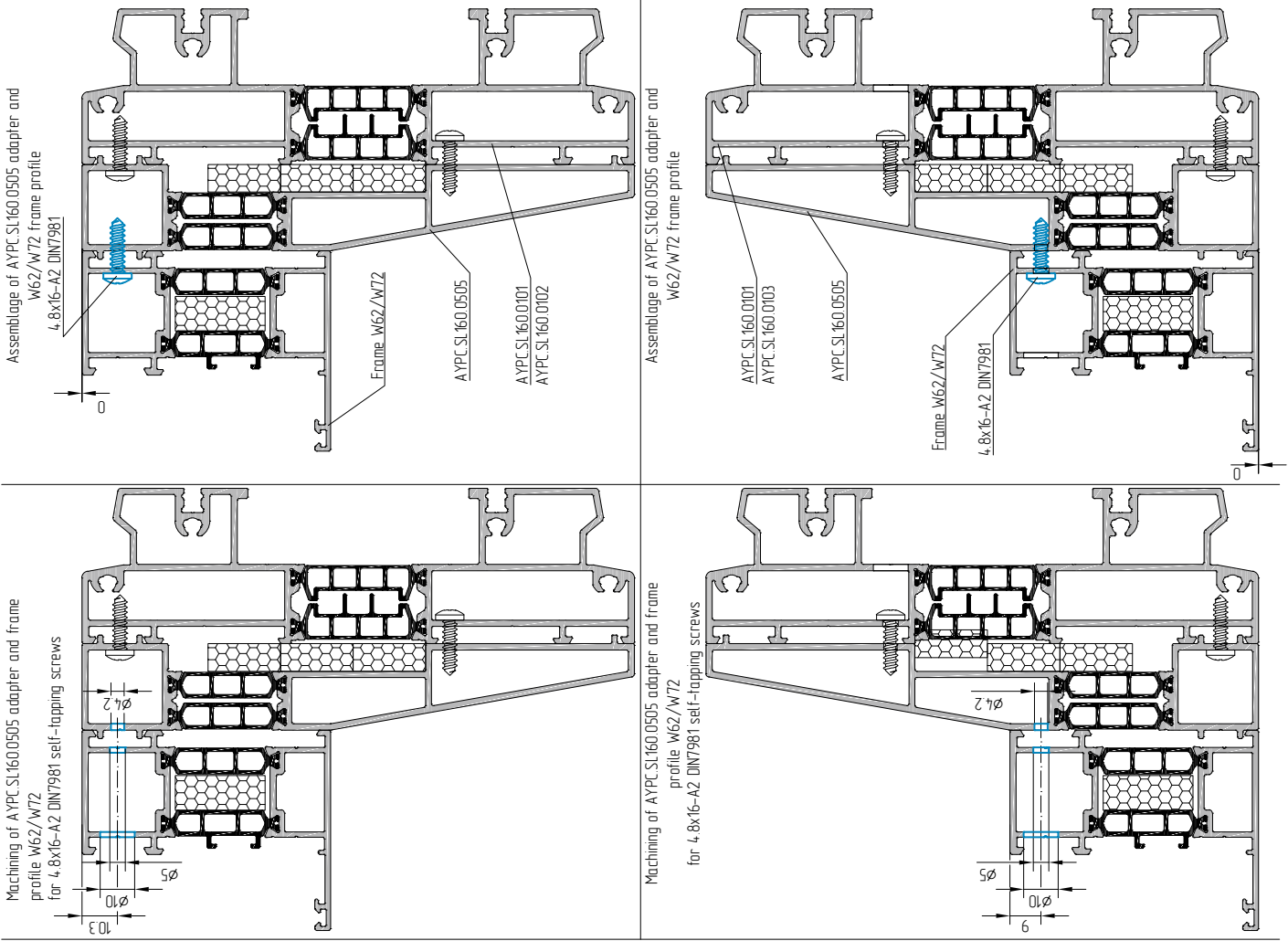

Avoid overlapping of holes!
Shift hole 2 by min 20 mm from hole 1

Preparation and installation of FRK175, FRK176 gaskets and FRK177, FRK178, FRK178-01 corners

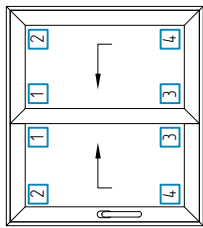

EPDM FRK175, FRK176 rebate gaskets

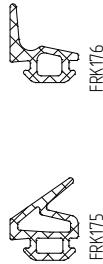

EPDM FRK177, FRK178, FRK178-01 rubber corner

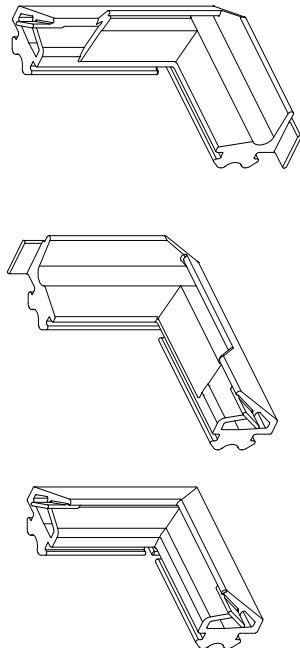

Processing of FRK177, FRK178, FRK178-01 corners for AYPCL160.094.0 ledge kit installation

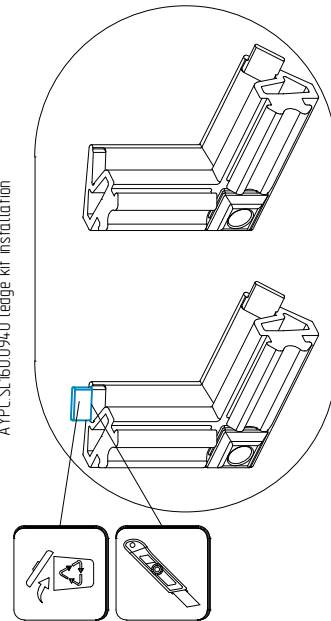

Cut FRK175, FRK176 gasket with 1% extra in length!
Do not allow any deformation!
Avoid the gaps!
Do not stretch during installation!

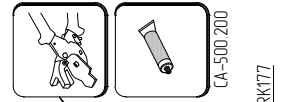
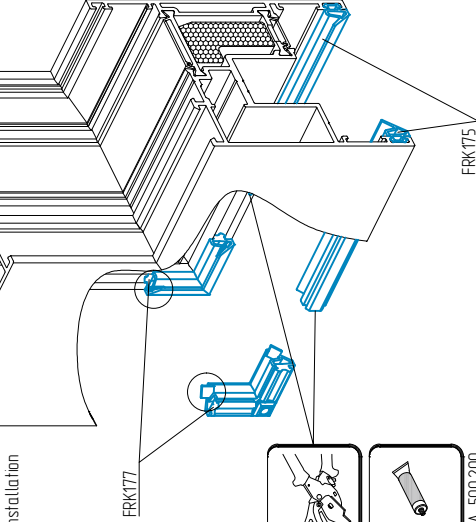
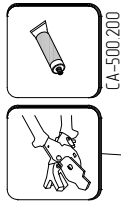
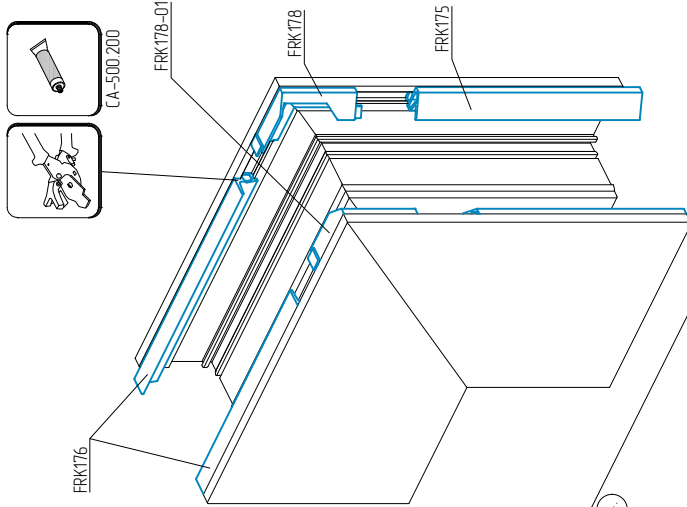
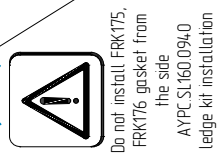
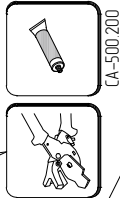
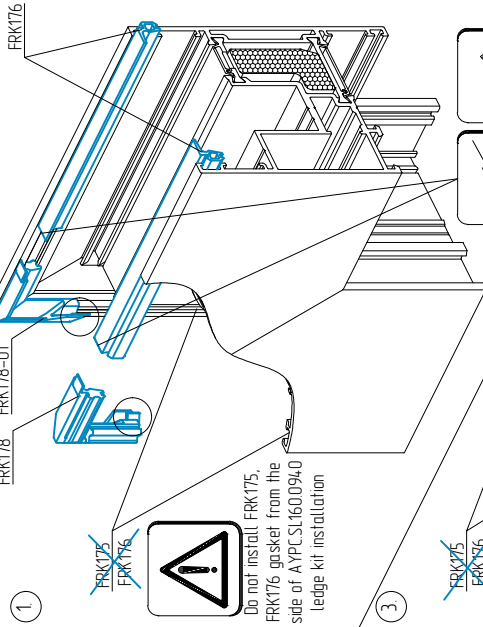

Installation of AYPC.SI.160.0904 levelers

AYPC.SI.160.0904 leveler with M4x10 DIN914 adjusting screw from AYPC.SI.160.0940 frame ledge kit

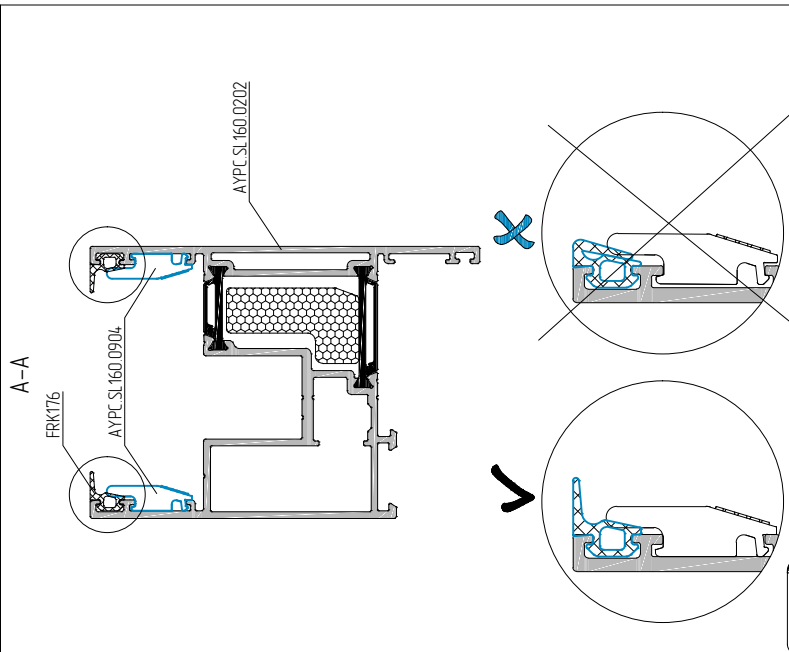
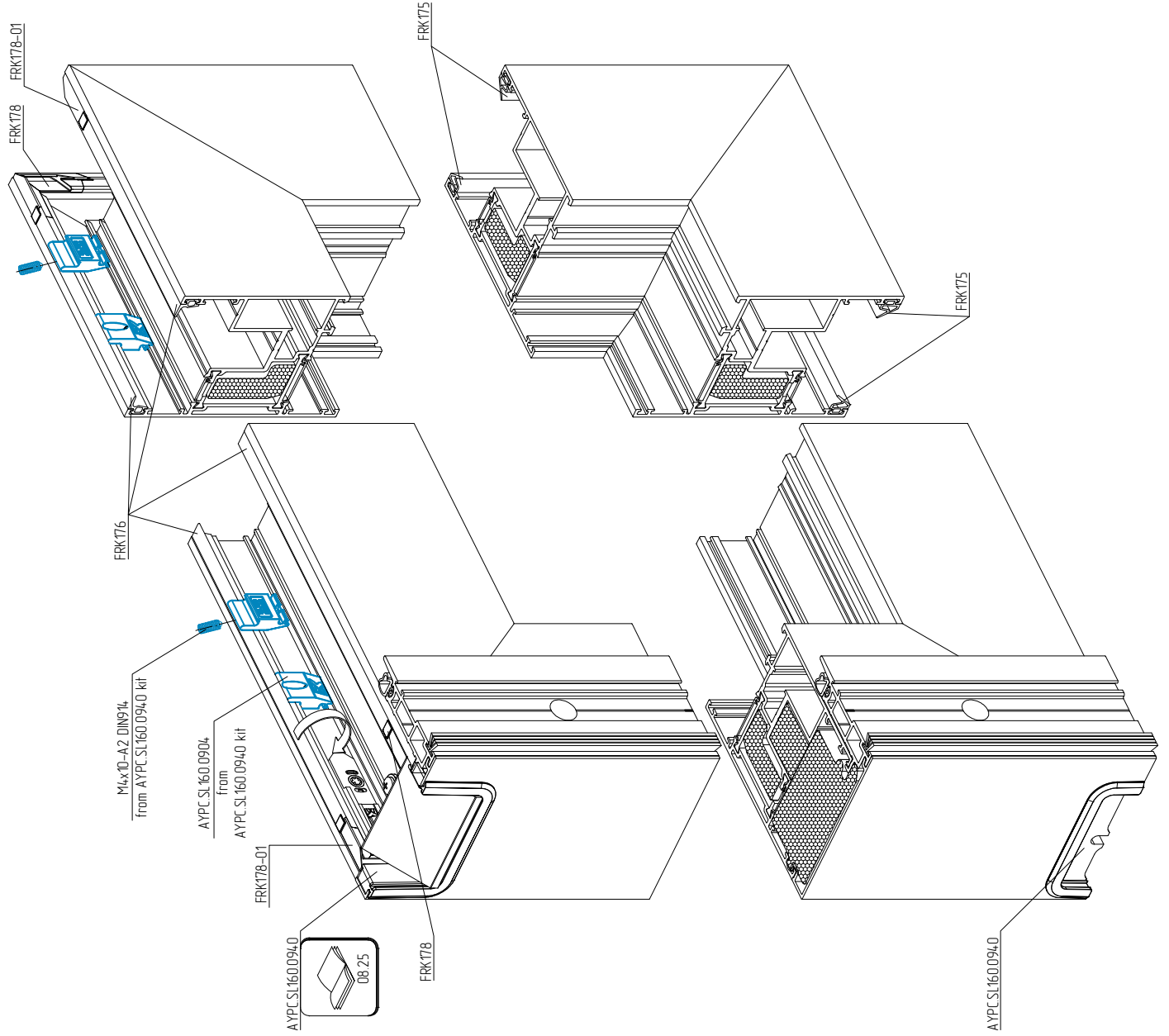
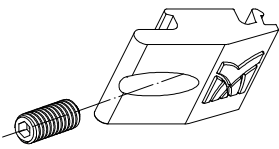
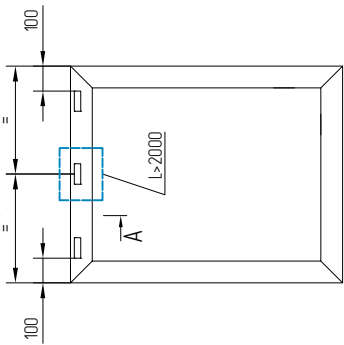

Do not allow any deformation of FRK176 during installation of AYPC.SI.160.0904!

Cutting and installation of FRK197/FRK93 gasket

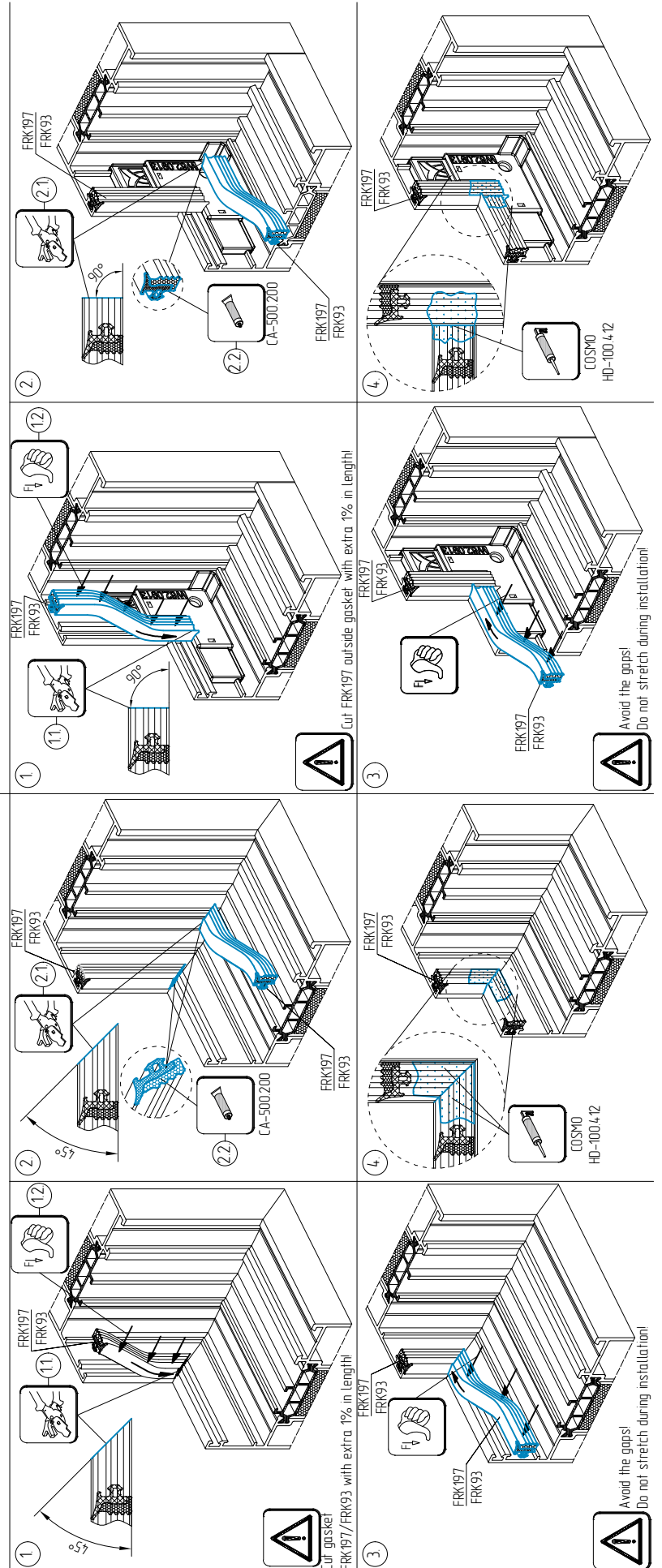
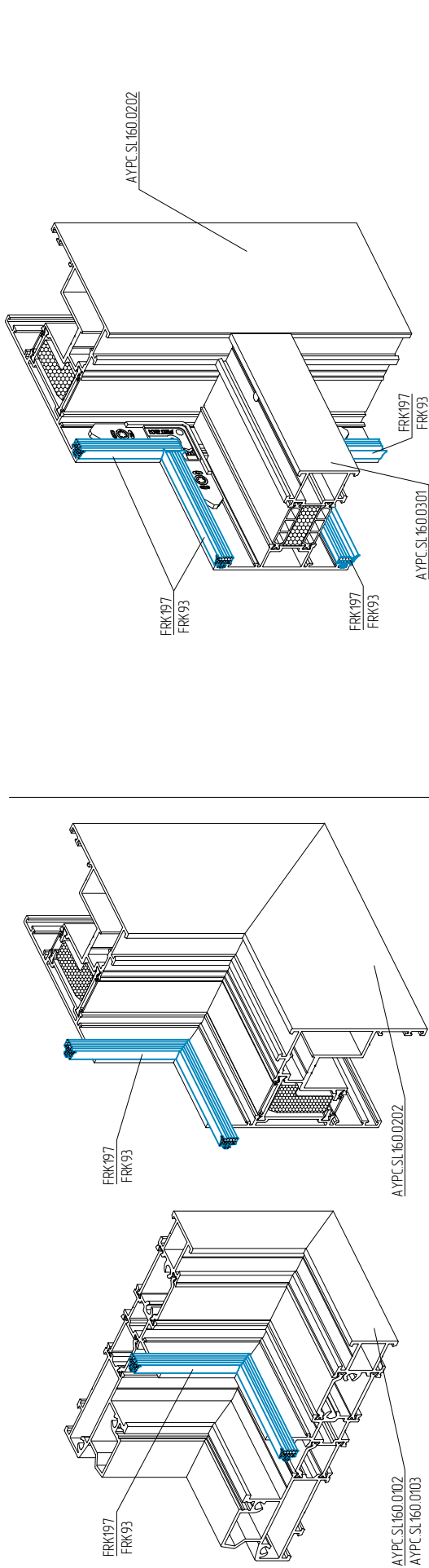

Cutting and installation plan of FRK197 outside gasket and FRK179 rubber corner

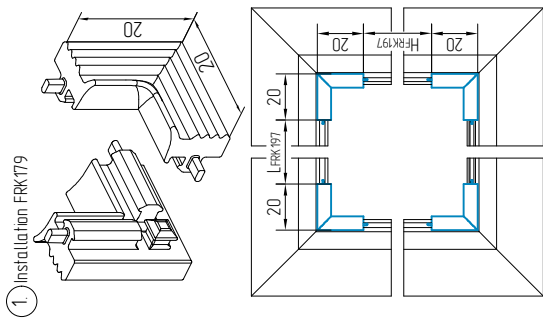
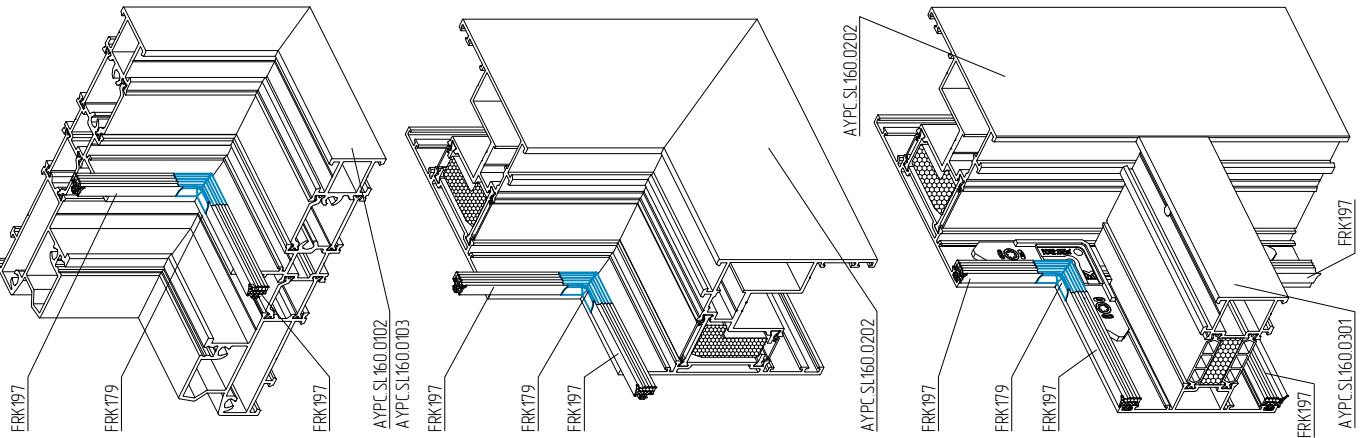

Do not allow any deformation!

3

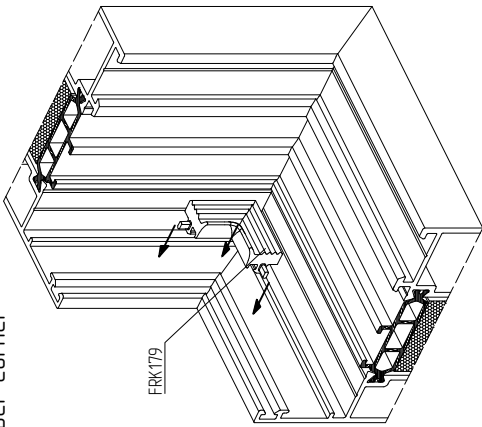

Do not allow any deformation!
Avoid the gaps!
Do not stretch while installation!

4

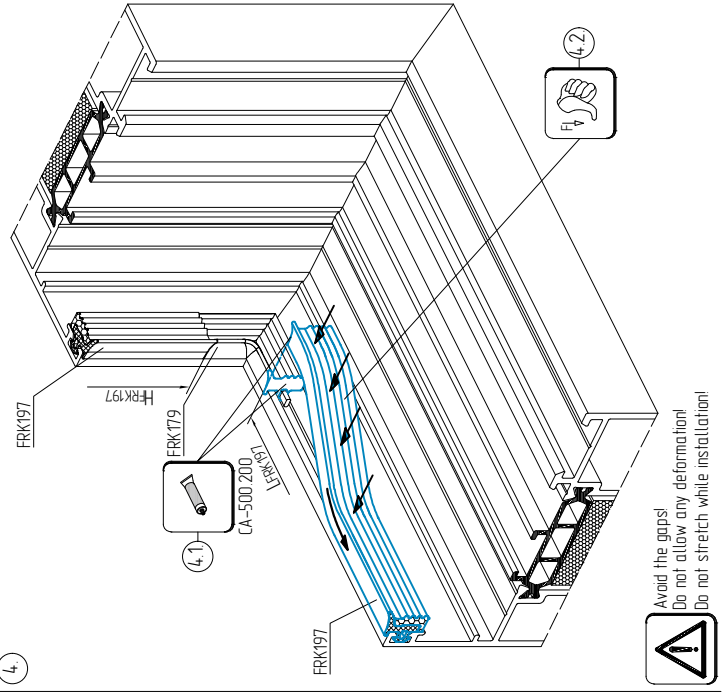

4 Avoid the gaps!
Do not allow any deformation!
Do not stretch while installation!

01

02

03

04

05

06

07

08

09

10

Installation of bearing and leveling supports

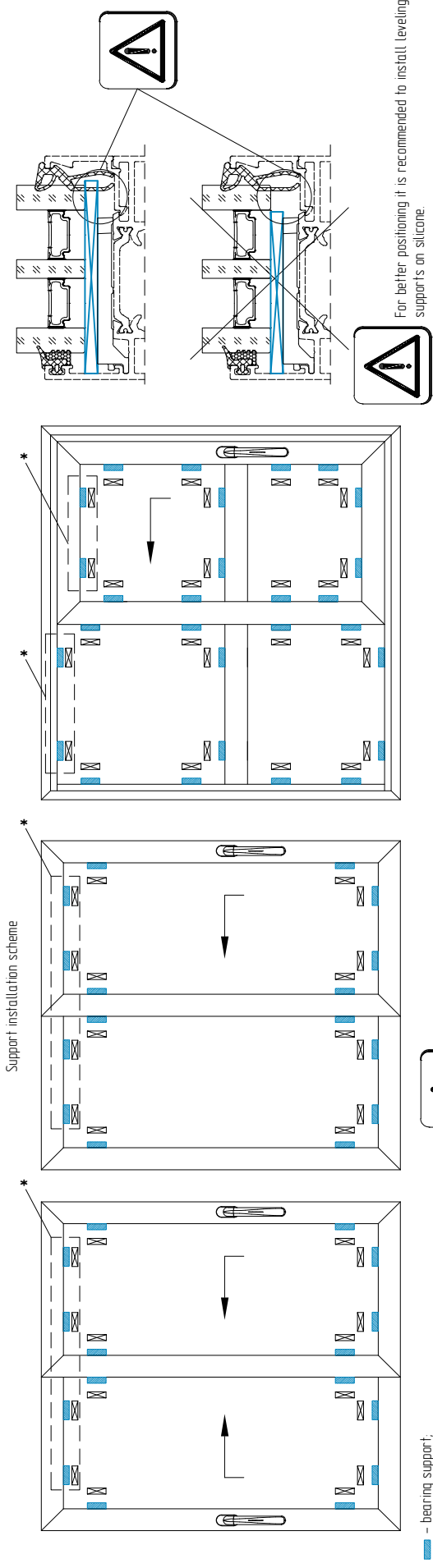

■ - bearing support;
⊠ - leveling support;
For selection of the size of leveling supports see section 05



Avoid sliding!



0

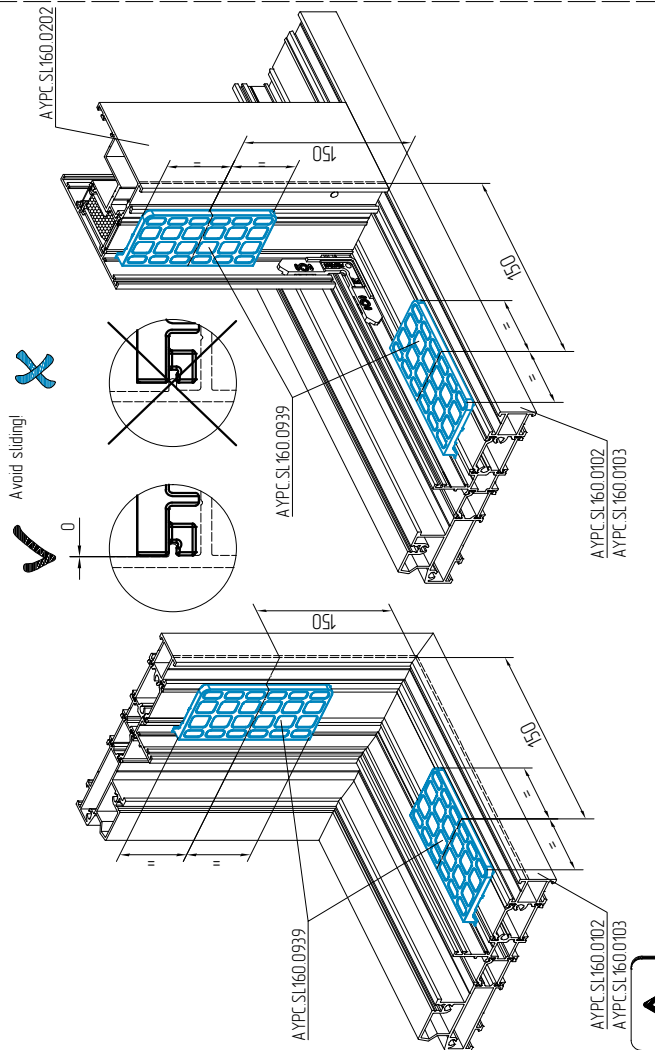
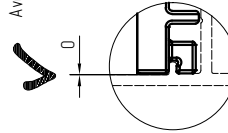

* It is recommended to use during transportation. Select size and quantity of leveling supports on site.



Cutting and installation scheme of the glass bead profile and gasket

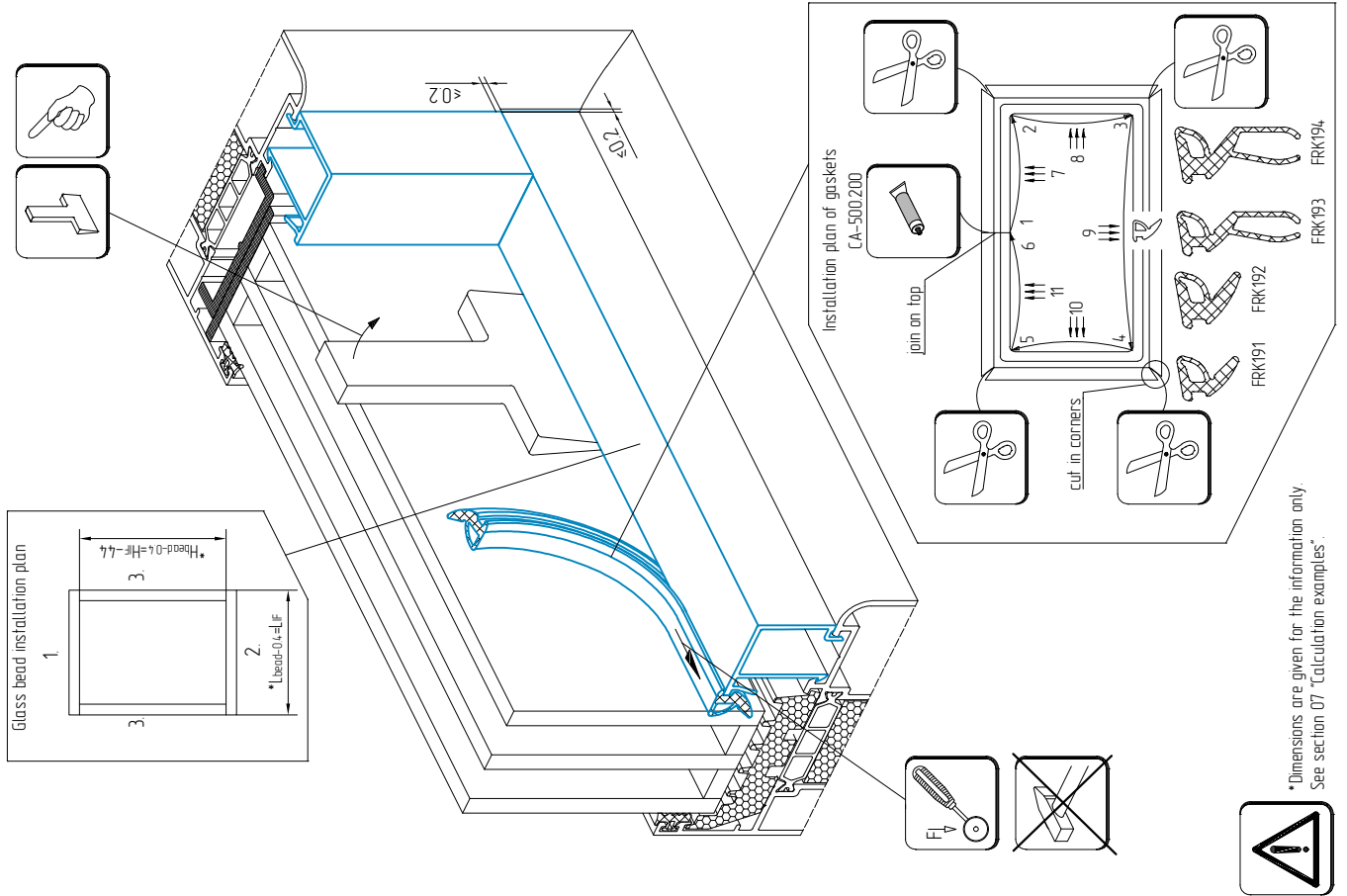

Seam sealing preparations

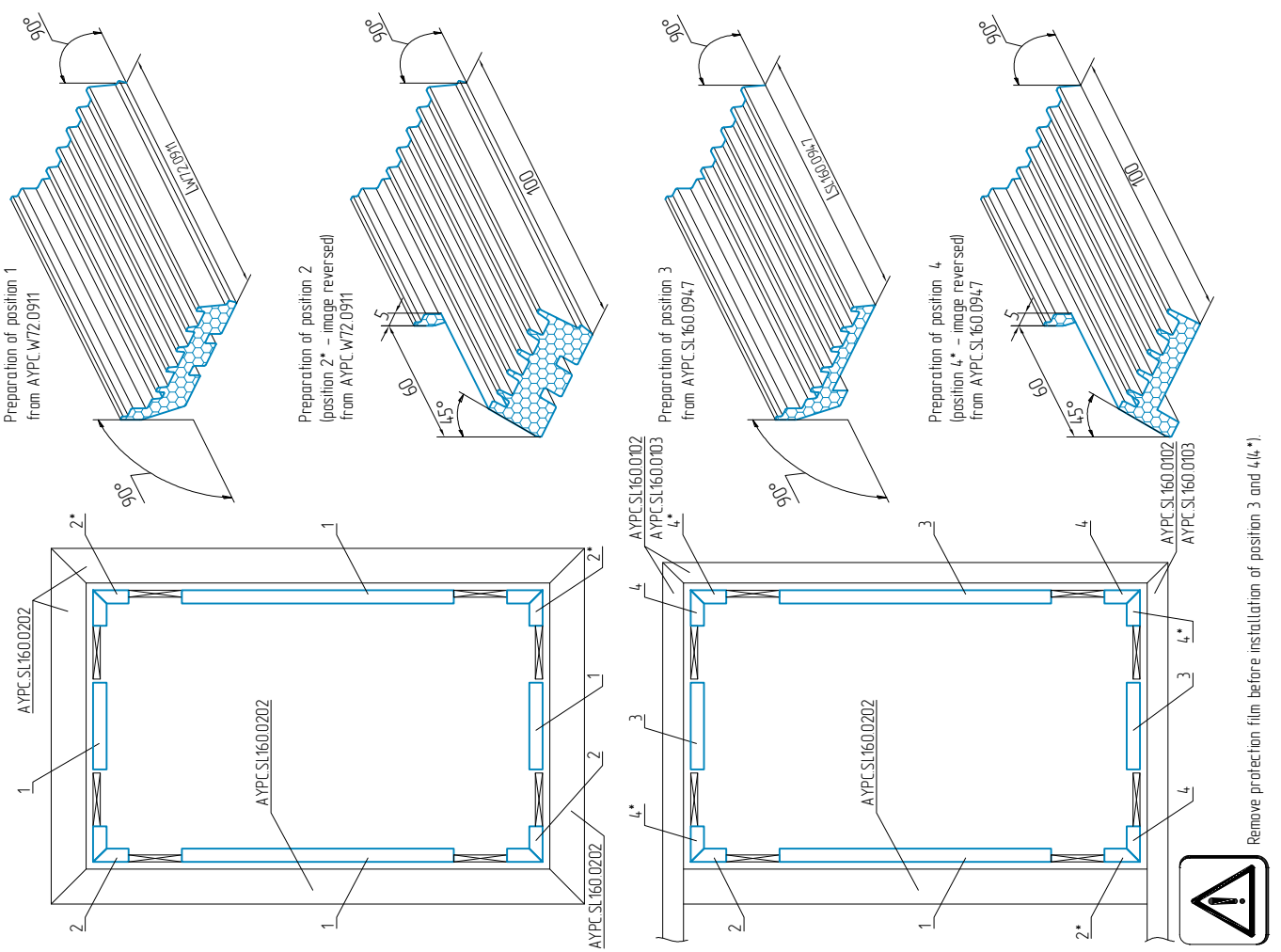

Machining of AYPC.SI.160.0102 and AYPC.SI.160.0103 frame profiles for connection kit installation, $L_{EF} > 6500$ mm

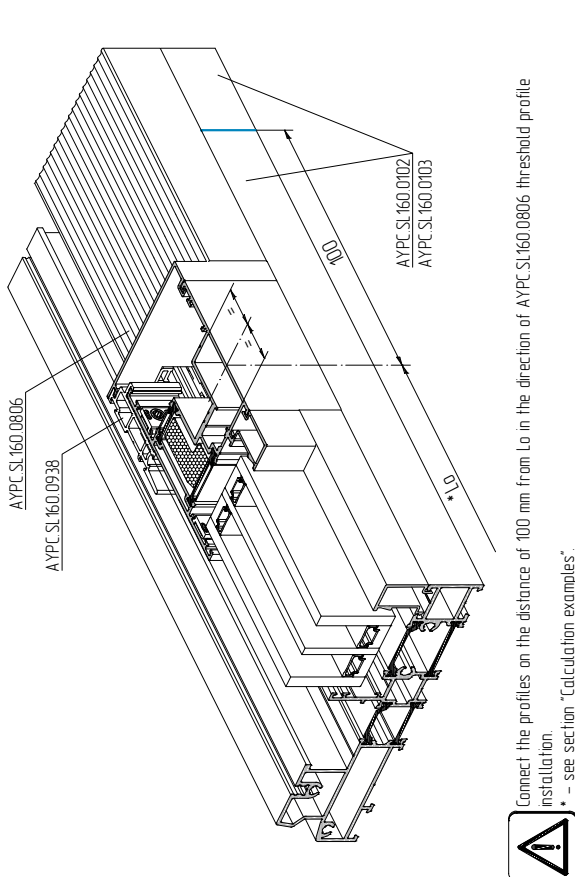
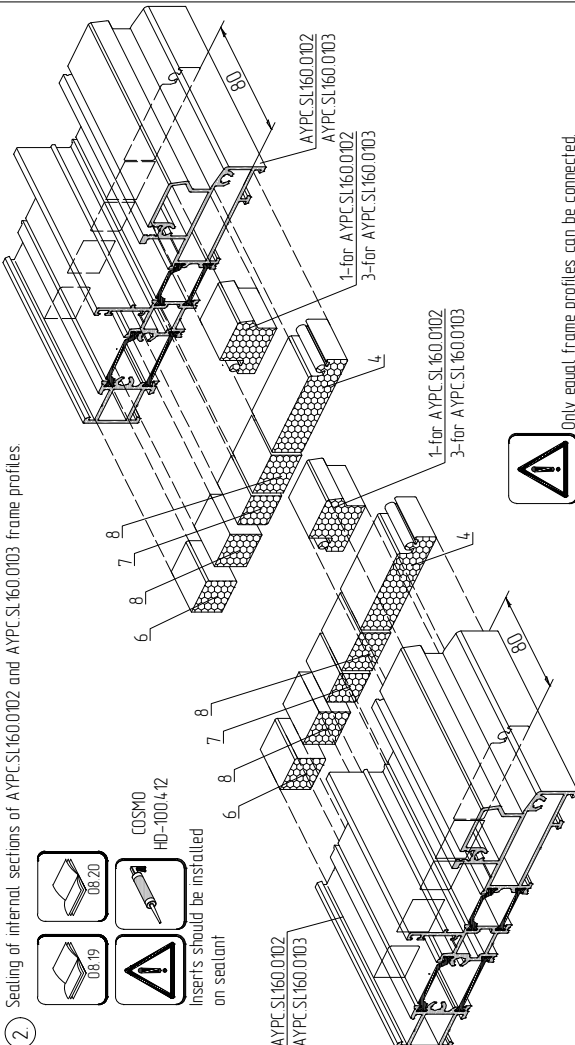
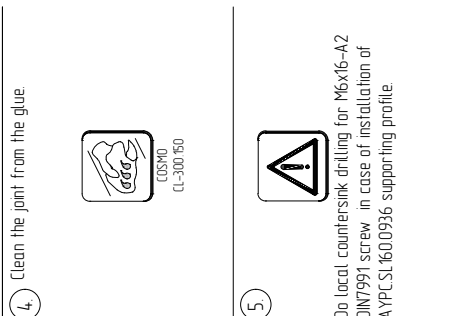
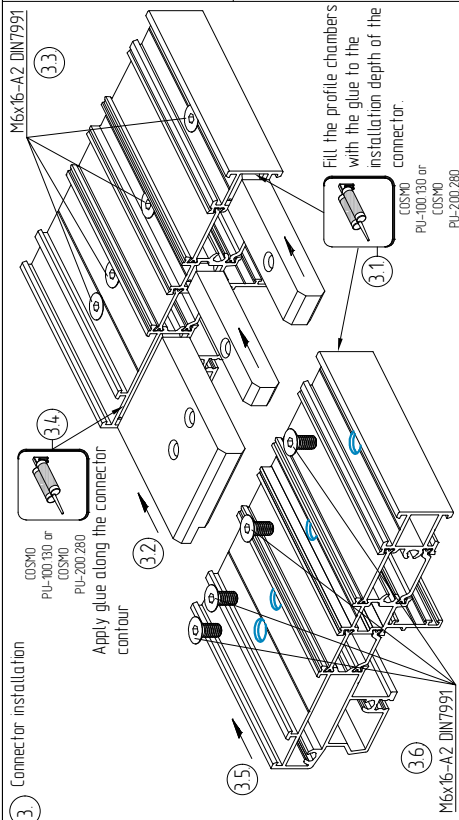
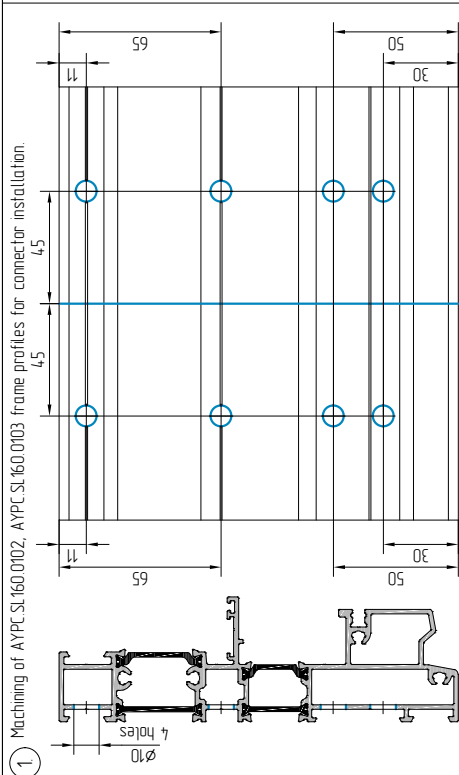
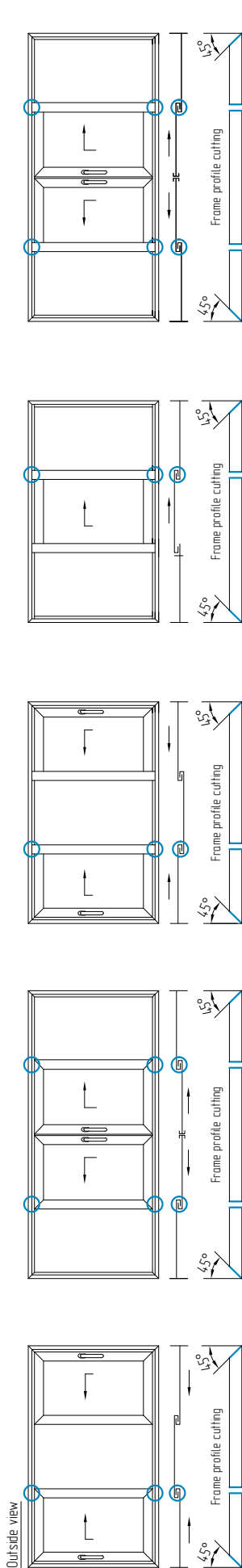

Machining of AYPC.SL160.0104 frame profile for connection kit installation, $L_{EF} > 6500$ mm

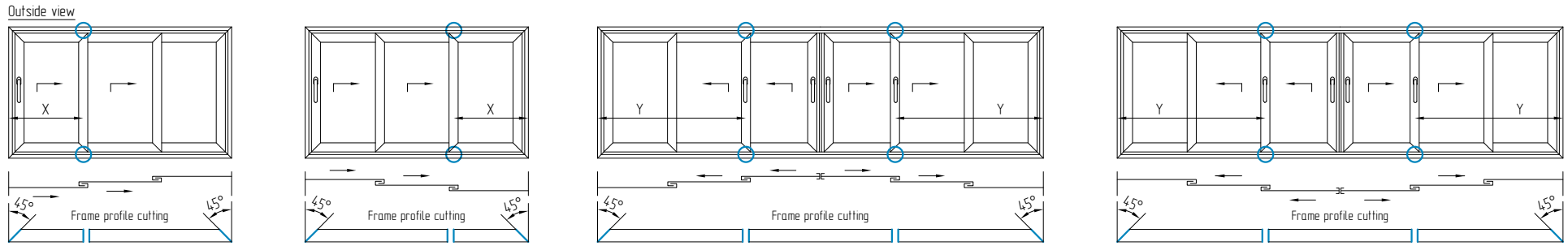

⚠ Join on the axis of symmetry of the sash ledge profiles

$X = L_{EF} / 3 + 27$
 $Y = L_{EF} / 3 - 6$

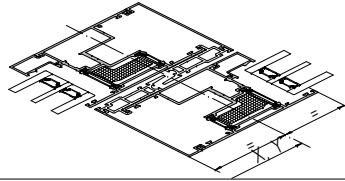

1. Machining of AYPC.SL160.0104 frame profile

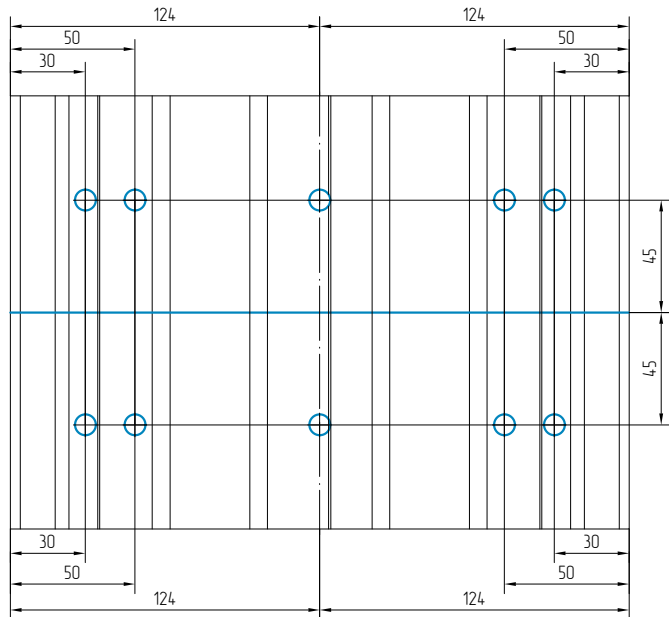
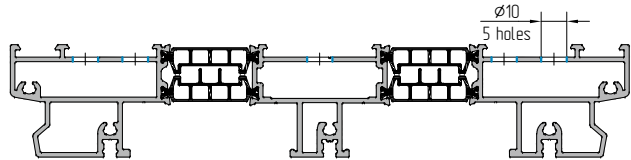

2. Sealing of AYPC.SL160.0104 internal sections



Inserts should be installed on sealant

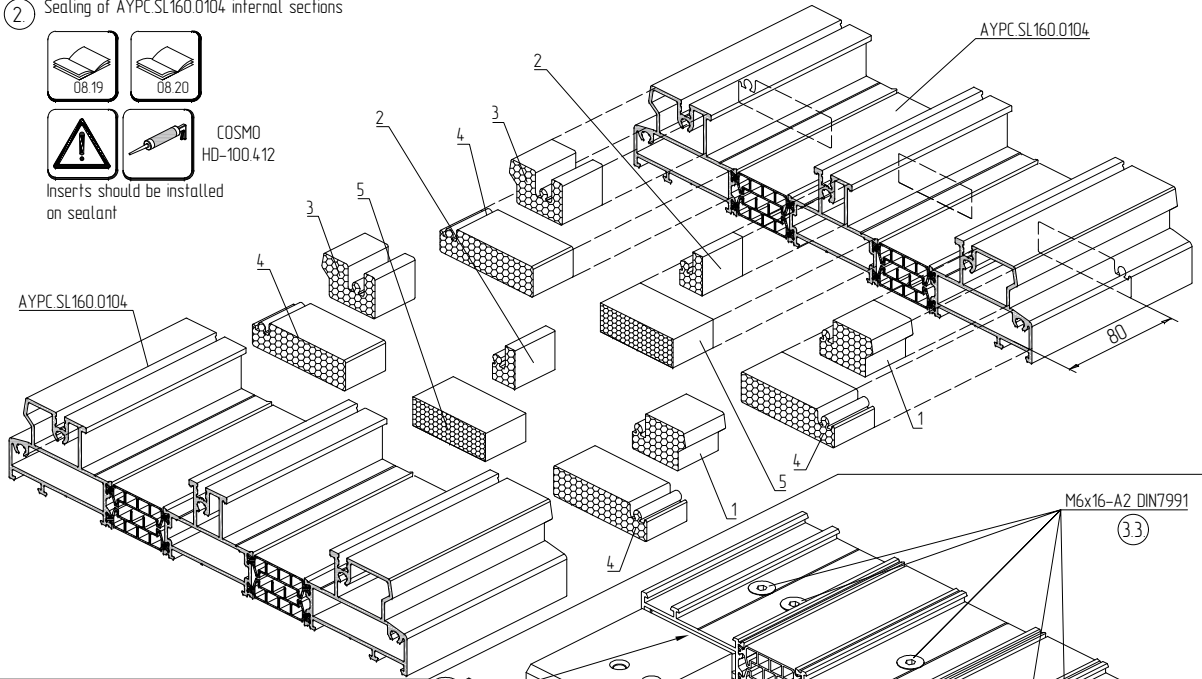

3. Connector installation

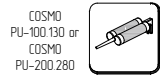

Apply glue along the connector contour

4. Clean the joint from the glue.



COSMO CL-300.150

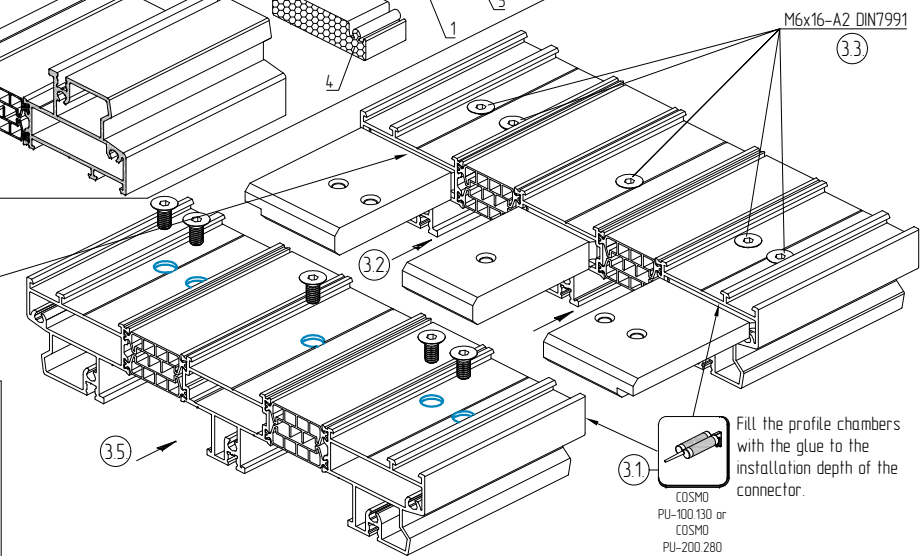

Machining of drainage holes in AYPCLSL160.0101 frame profile, $L_{EF} > 6500$ mm

Outside view

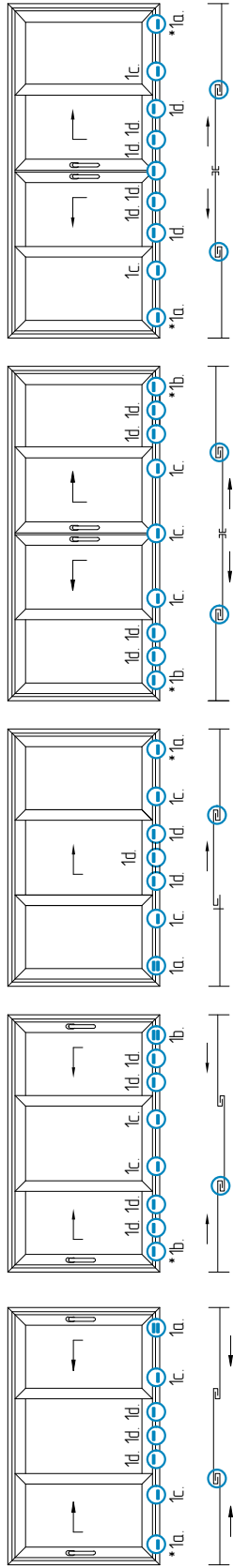

1c



Do not do machining 'B'.
Do not install AYPCLSL160.0929 plug

1b



Do not do machining 'A'.
Do not install AYPCLC48.0919M-01

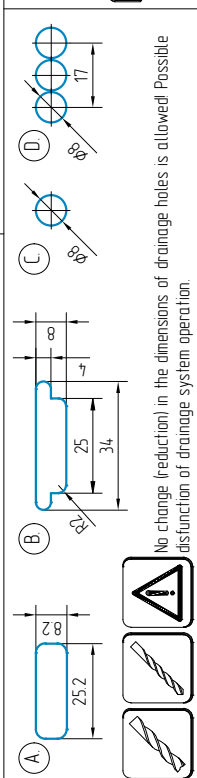
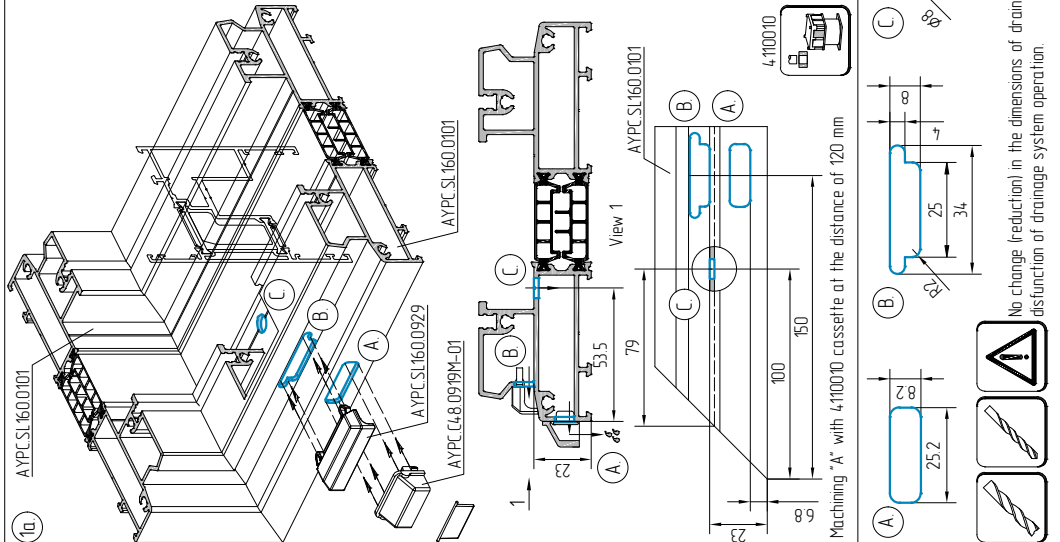
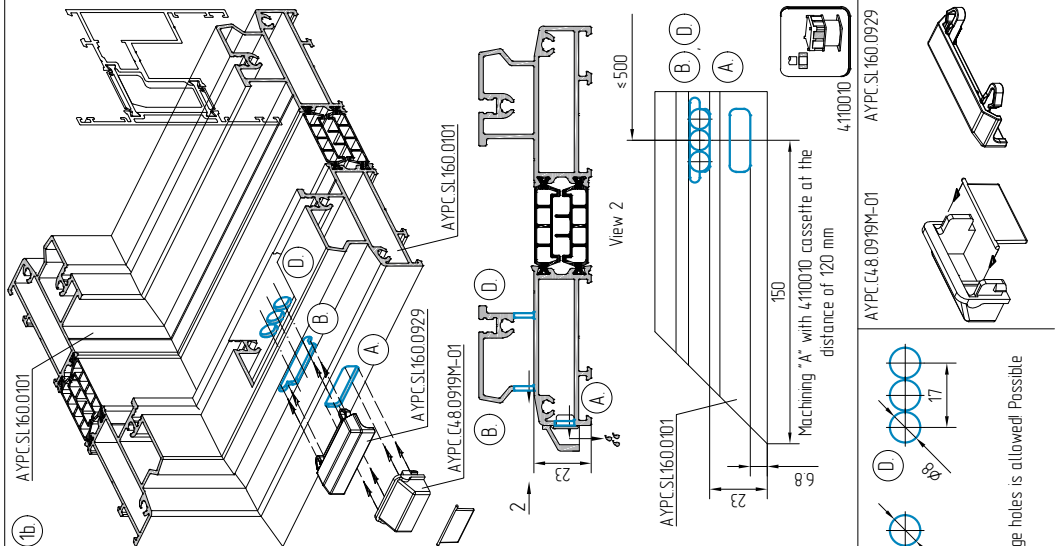
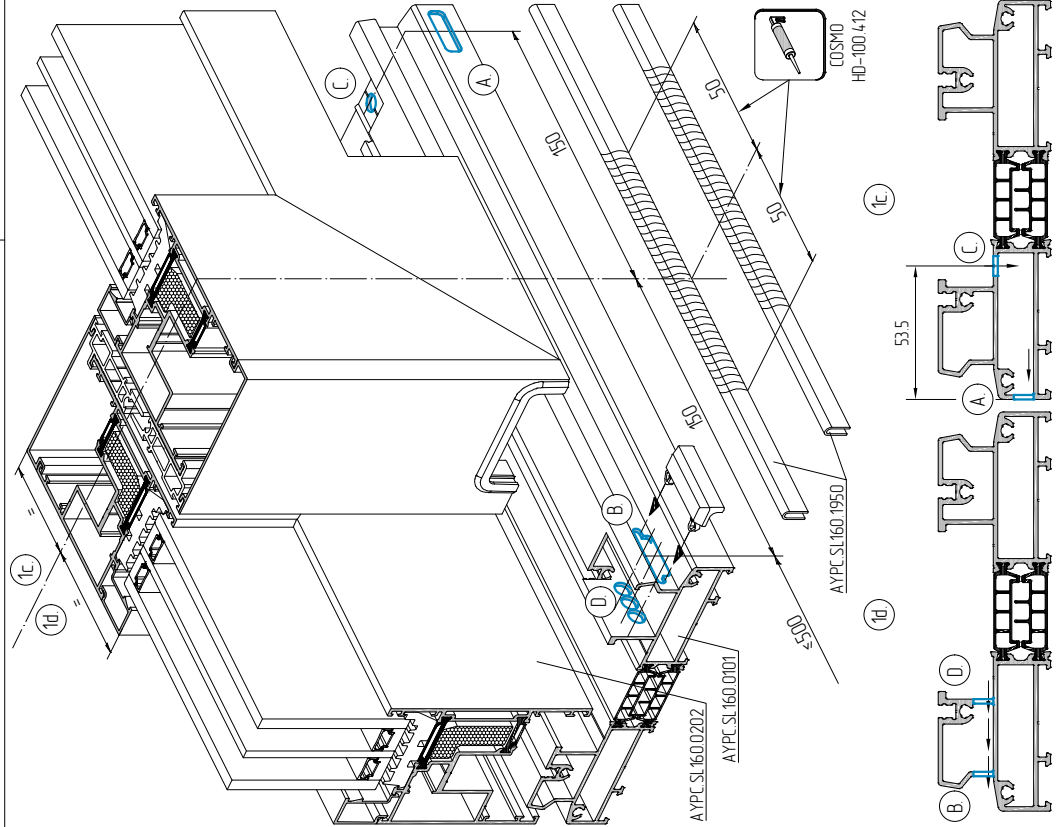

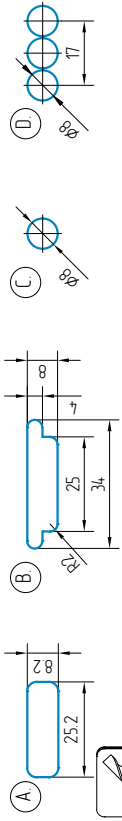

No change (reduction) in the dimensions of drainage holes is allowed!
Possible dysfunction of drainage system operation.

AYPC SL160.0929

AYPC C4.8.0919M-01

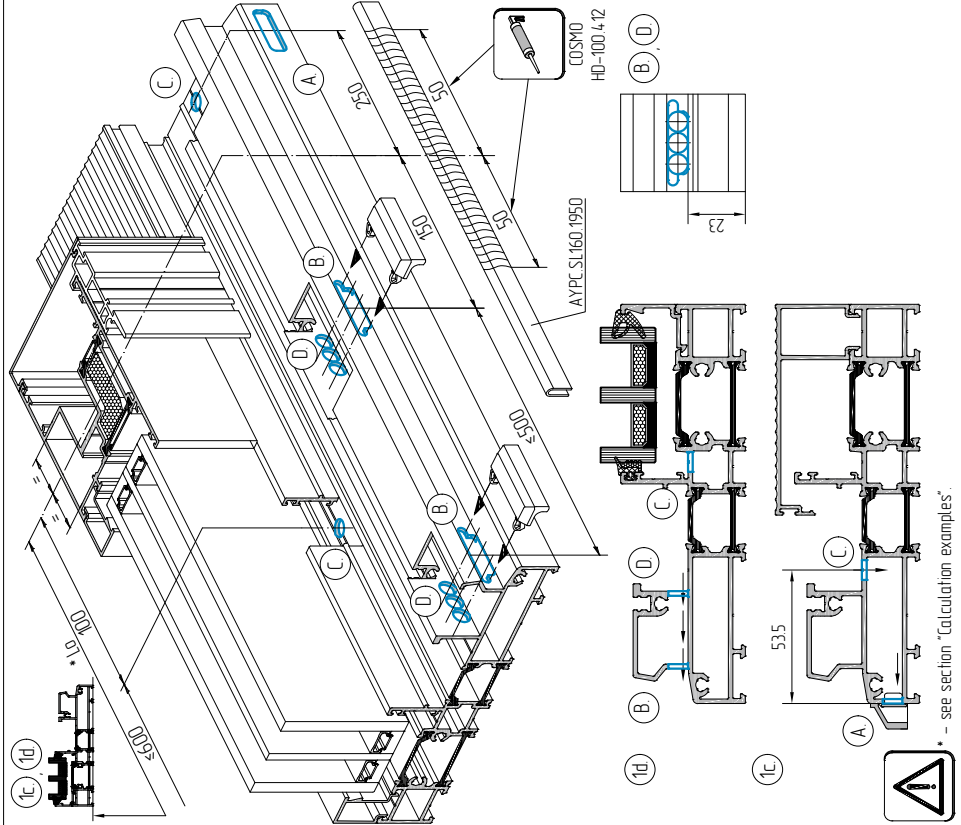
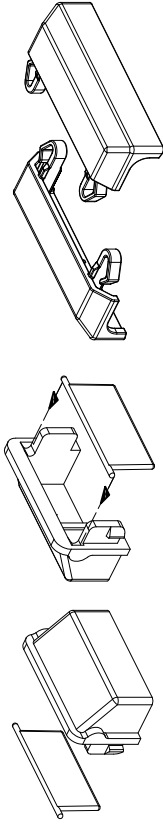

Machining of drainage holes in AYPC.SL160.0102 frame profile, L_{EF} > 6500 mm

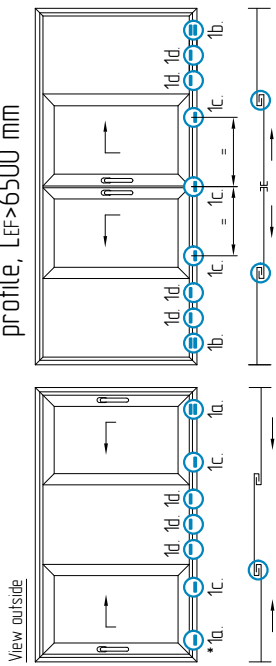

Do not do machining "B".
Do not install AYPC.SL160.0929 plug

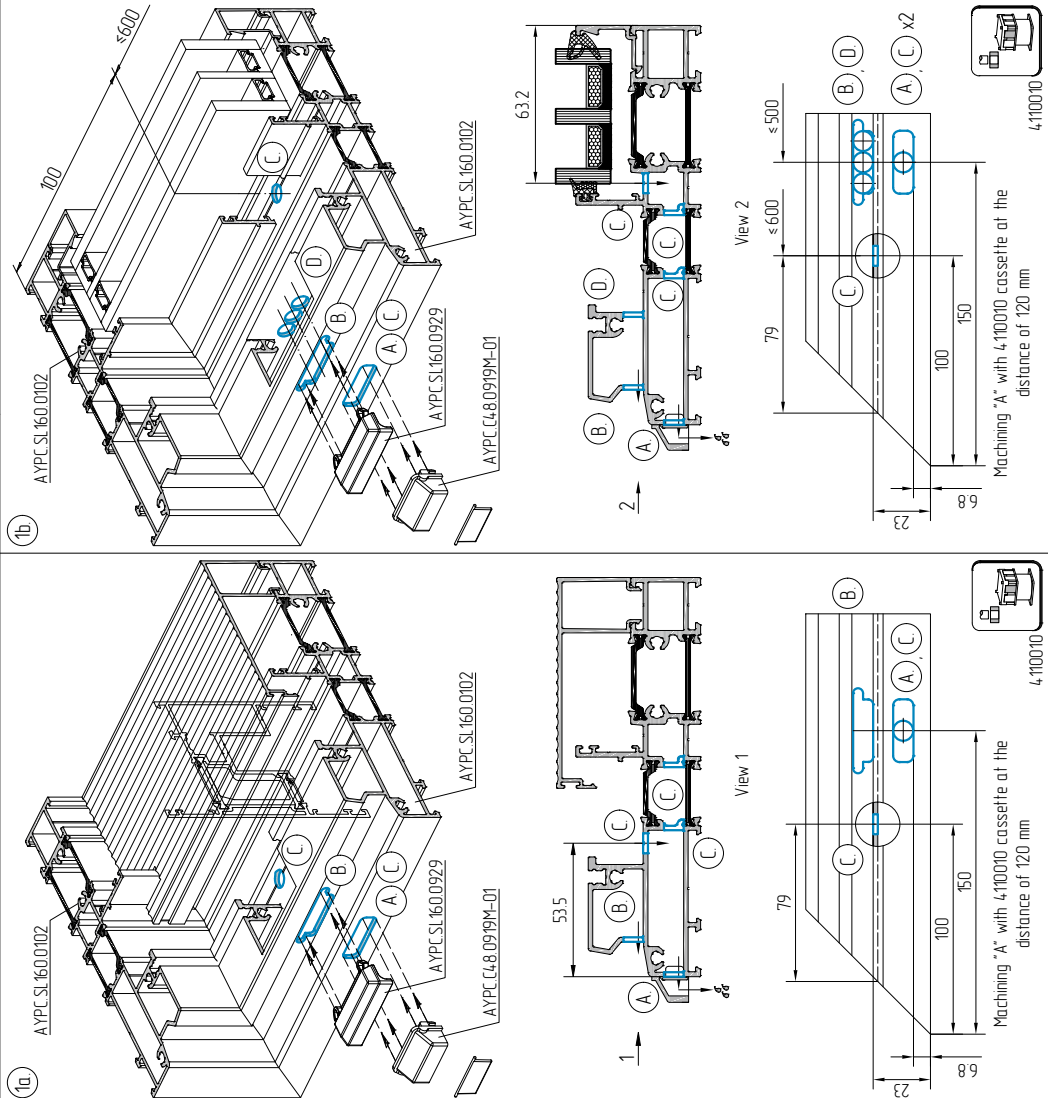

Machining of drainage holes in AYPC.SI.160.0103 frame profile, L_{EF}>6500 mm

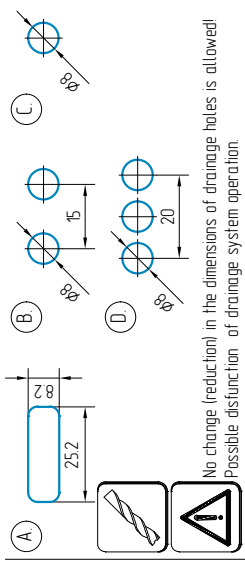
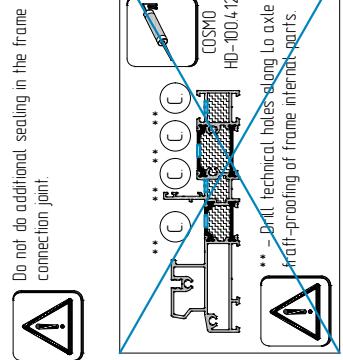
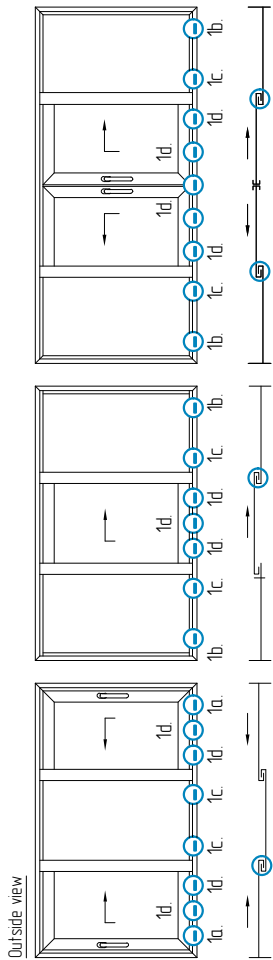

No change (reduction) in the dimensions of drainage holes is allowed! Possible disfunction of drainage system operation.

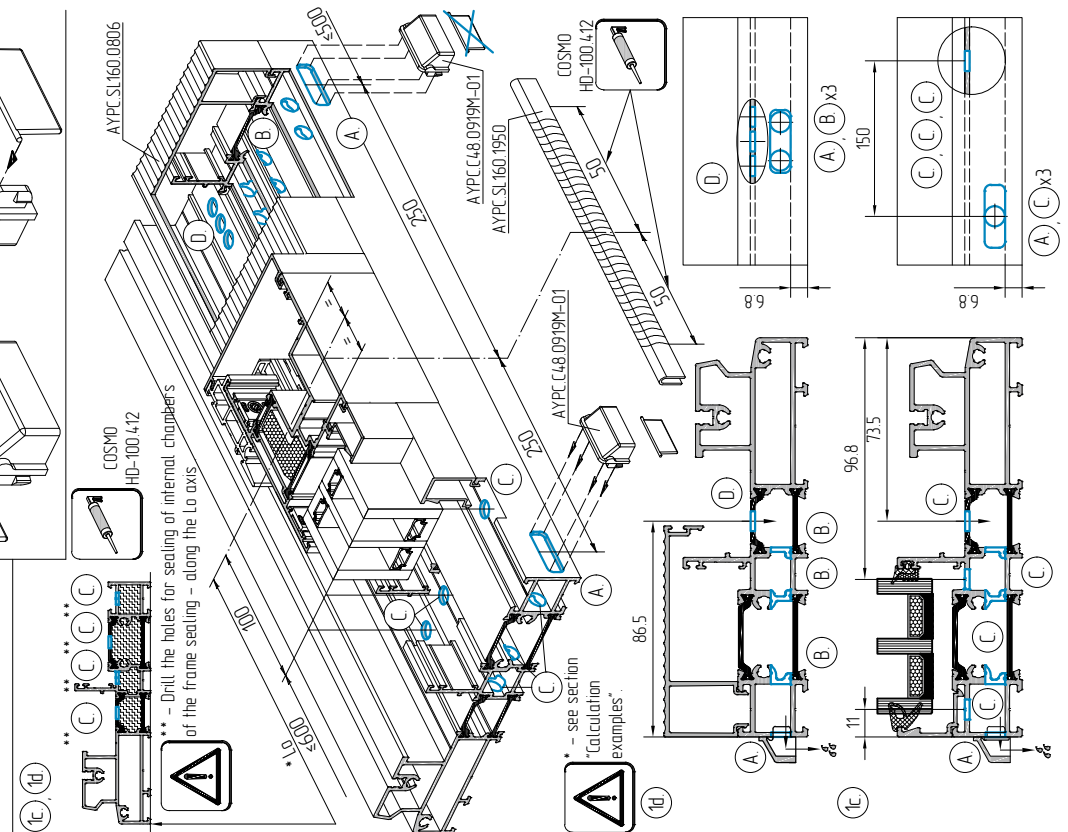
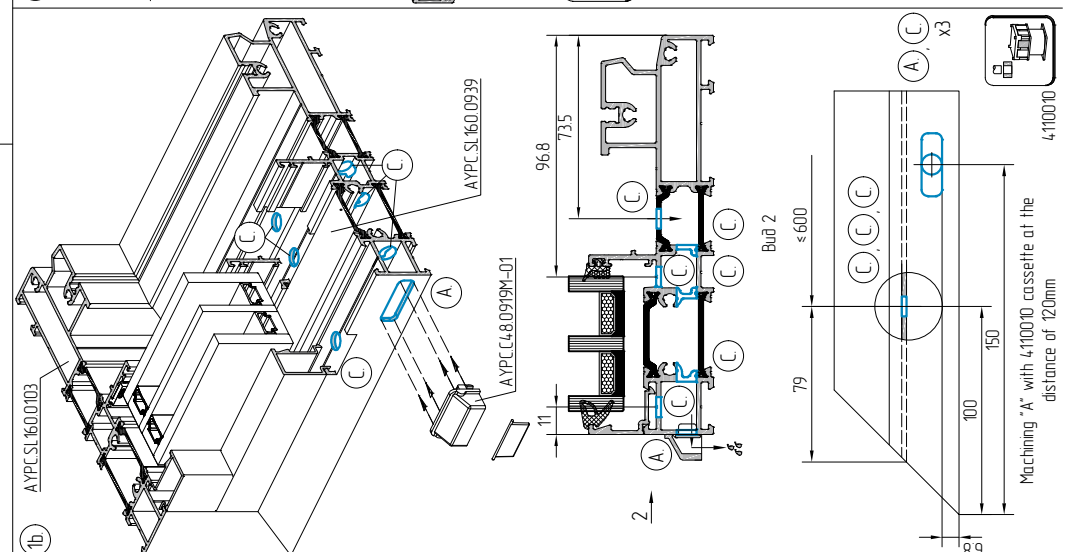
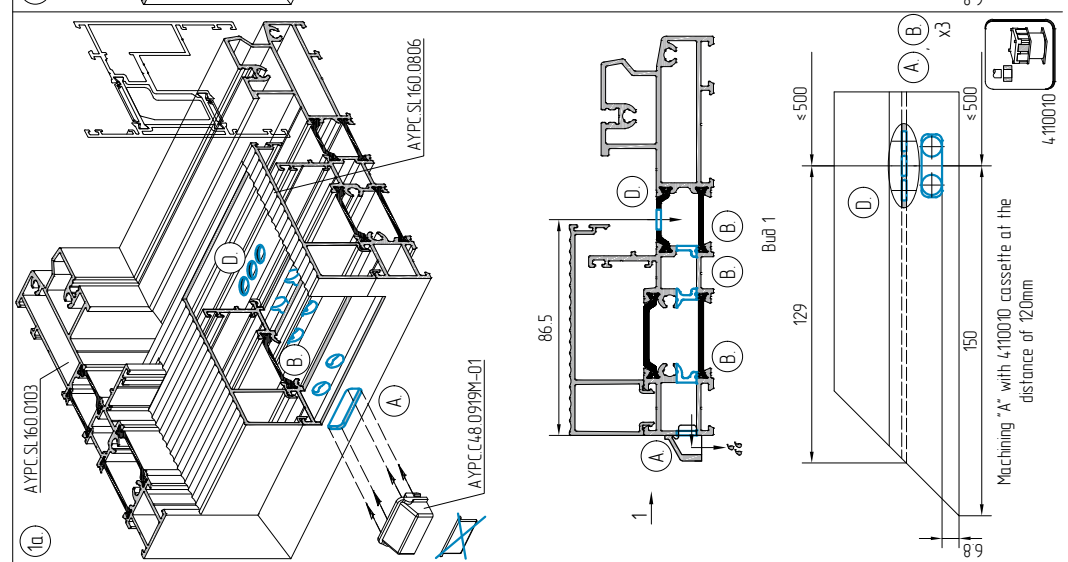

Machining of drainage holes in AYPCL160.0104 frame profile, $L_{EF} > 6500\text{mm}$

Outside view

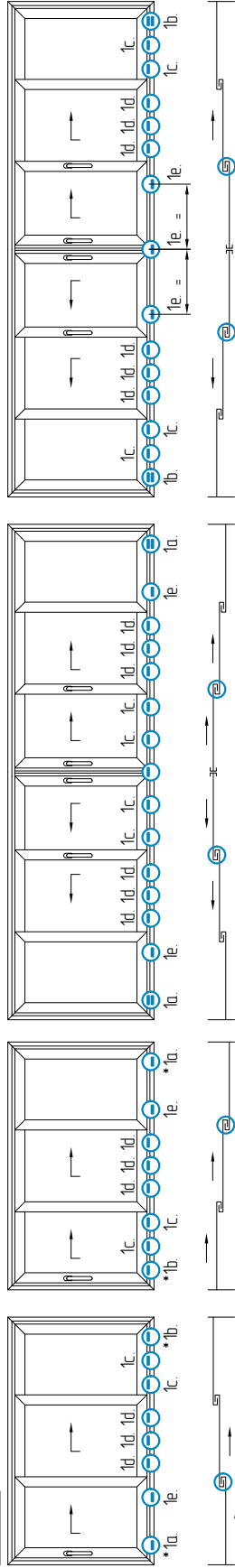

(1a)

Do not do machining "B".
Do not install
AYPCS160.0929 plug

(1b)

Do not do machining "A".
Do not install
AYPC C48.0919M-01 plug

(1a)

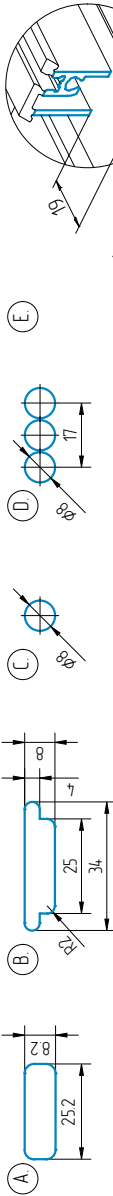
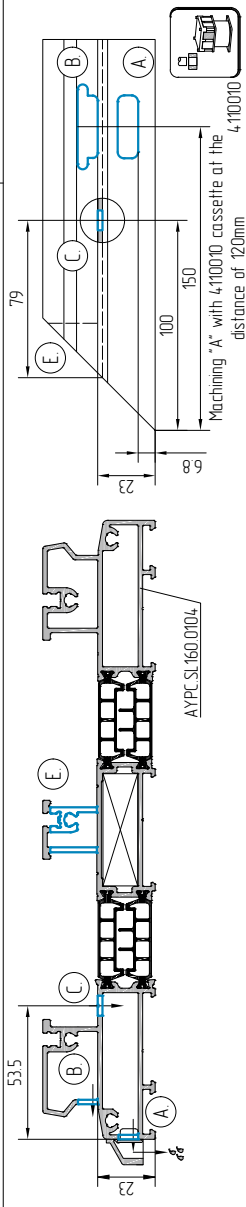

No change (reduction) in the dimensions of drainage holes is allowed!
Possible distortion of drainage system operation.

(1b)

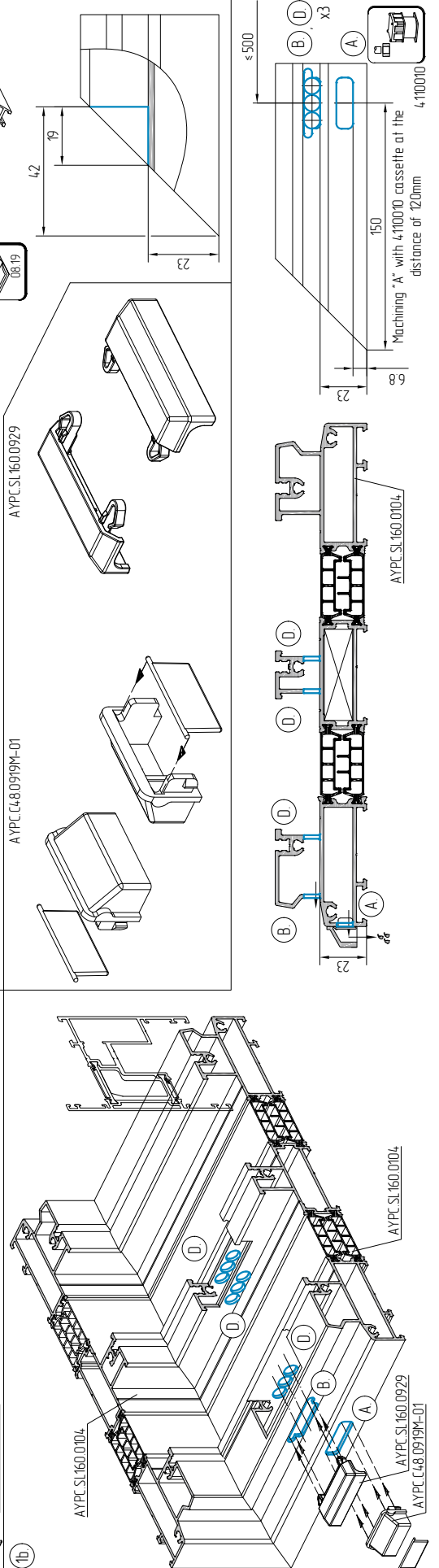



Do not do machining "B".
Do not install.
AYP.C.SI.160.0929 plug.



Do not do machining "A".
Do not install.
AYP.C.168.0919M-01 plug.

Machining of drainage holes in AYP.C.SI.160.0104 frame profile, $L_{EF} > 6500\text{mm}$

Outside view

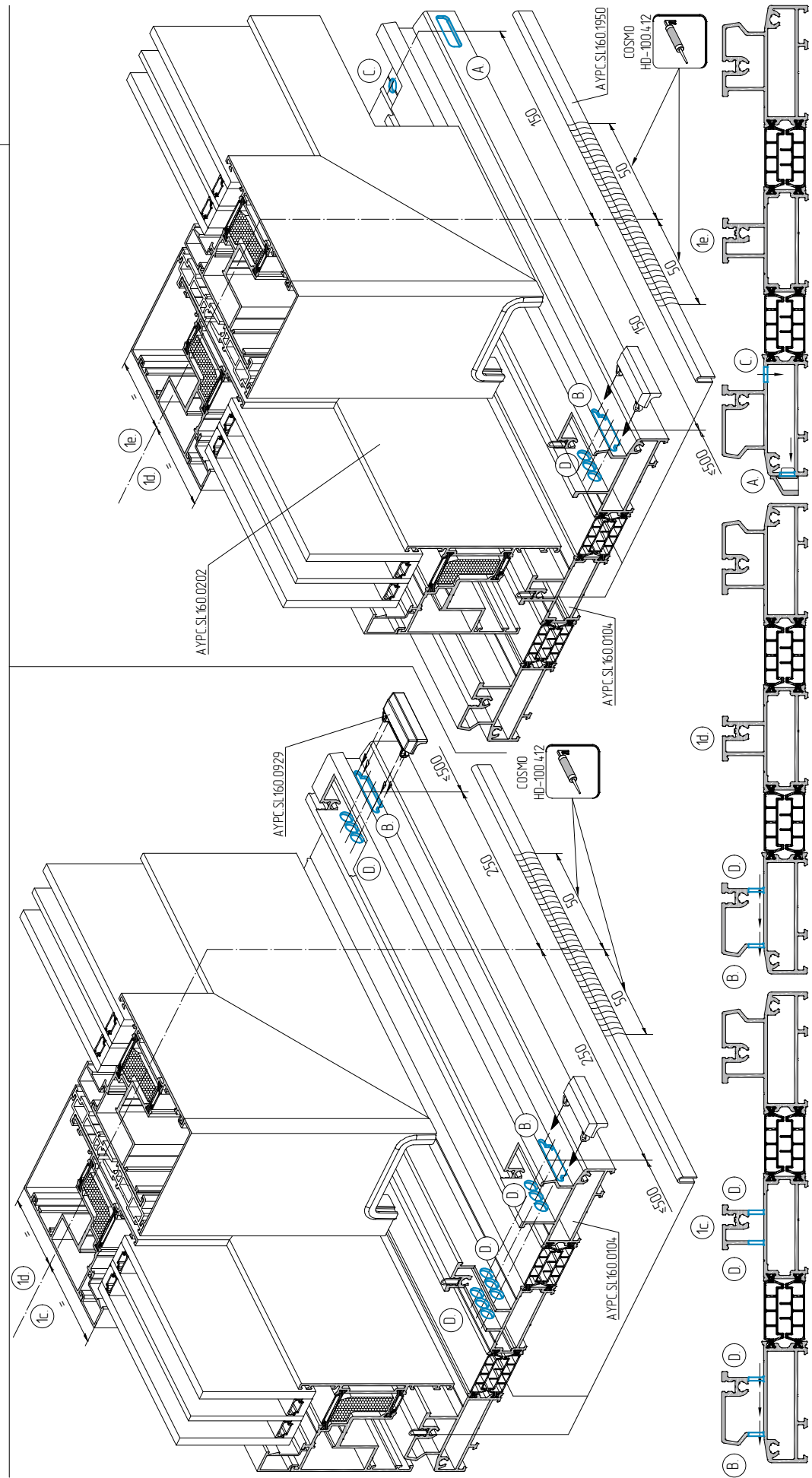
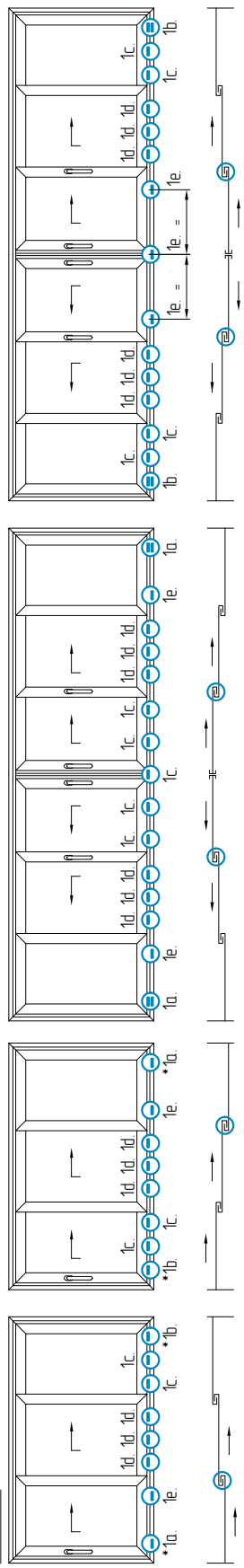

01

02

03

04

05

06

07

08

09

10

L_{EF}>6500mm. Profile connection











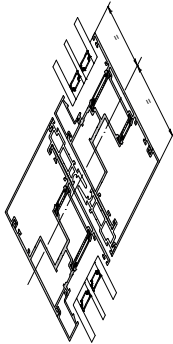







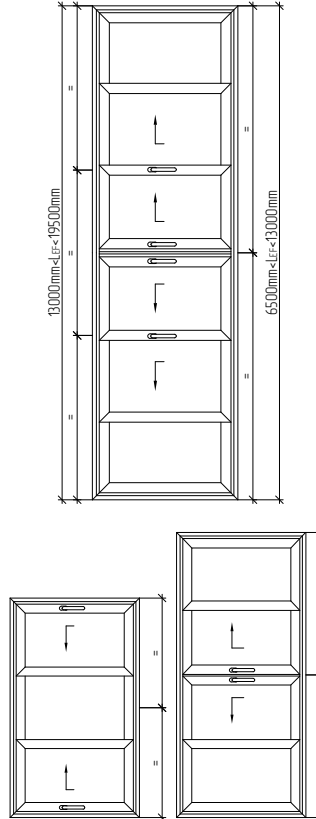

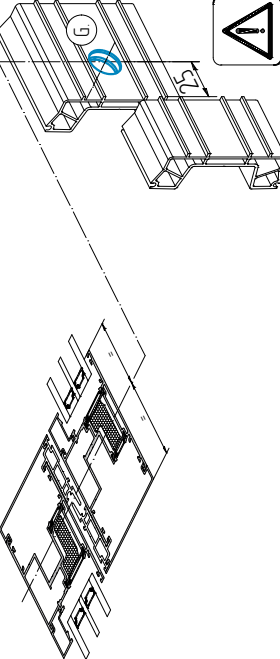



Profile	Connection joint	Comments
<p>AYPC SL160.0801 AYPC SL160.0812</p>		       <p>Fastening holes should be made in accordance with frame connectors installation.</p>
<p>AYPC SL160.0804 AYPC SL160.0805 AYPC SL160.0810 AYPC SL160.0811</p>		  <p>Fastening holes should be made in accordance with frame connectors installation. Do connection joint of AYPC SL160.0810 and AYPC SL160.0811 threshold profiles in the center of the door.</p>
<p>AYPC SL160.0920 AYPC SL160.0923</p>	 	       <p>Seal the opened edge after the first section installation Install the other sections in the same way Clean the joints from of the excess glue</p>
<p>AYPC SL160.0921 AYPC SL160.0922</p>		     <p>Seal the opened edge after the first section installation Install the other sections in the same way Clean the joints from of the excess glue</p>
<p>AYPC SL160.1950</p>		  <p>Seal the opened edge after the first section installation Install the other sections in the same way Clean the joints from of the excess glue</p>

Table of frame connectors and sealing inserts in accordance with door type

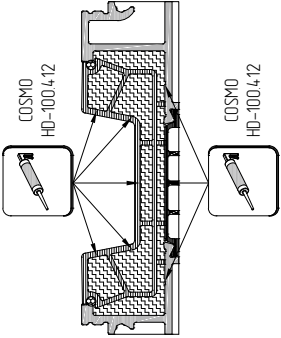
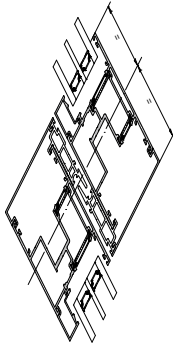
Door type	Frame connector			Sealing inserts				Fastener	
	AYPC.SI.160.0953	AYPC.SI.160.0954	AYPC.SI.160.0954-01	AYPC.SI.160.0954-02	AYPC.SI.160.0943	AYPC.SI.160.0944	AYPC.SI.160.0945		AYPC.SI.160.0946
Type A4	4	-	-	-	2	-	2	4	M6x16-A2 DIN7991 screw
Type A5	4	-	-	-	2	-	2	4	16
Type A6	4	-	-	-	2	-	2	4	16
Type A7	8	-	-	-	4	-	4	8	32
Type A8	8	-	-	-	4	-	4	8	32
Type A9	8	-	-	-	4	-	4	8	32
Type A10	8	-	-	-	4	-	4	8	32
Type B2	2	-	2	2	2	-	-	6	16
Type B3	4	-	4	4	4	-	-	12	32
Type C2	2	-	2	2	-	-	2	6	16
Type C3	2	-	2	2	-	-	2	6	16
Type C4	4	-	4	4	-	-	4	12	32
Type D1	4	2	-	-	2	2	2	6	20
Type D2	4	2	-	-	2	2	2	6	20
Type D3	4	2	-	-	2	2	2	6	20
Type D4	4	2	-	-	2	2	2	6	20
Type D5	8	4	-	-	4	4	4	12	40
Type D6	8	4	-	-	4	4	4	12	40
Type D7	8	4	-	-	4	4	4	12	40
Type D8	8	4	-	-	4	4	4	12	40

Classification of frame connectors

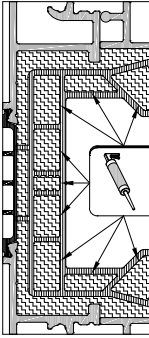
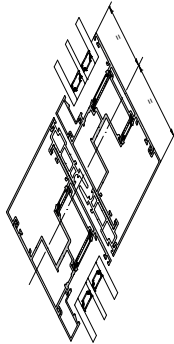

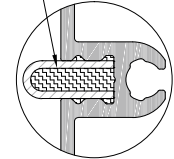
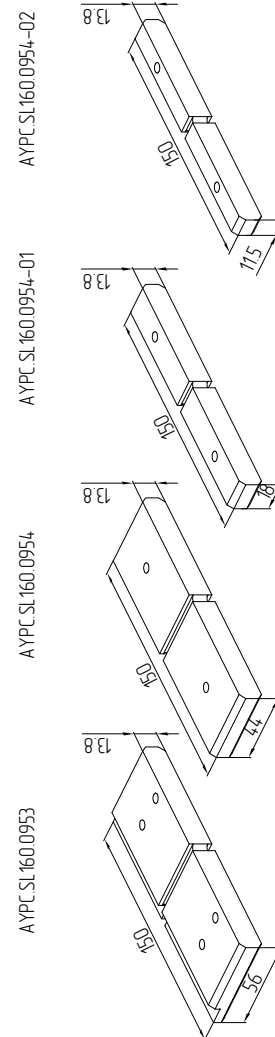
Classification of sealing inserts

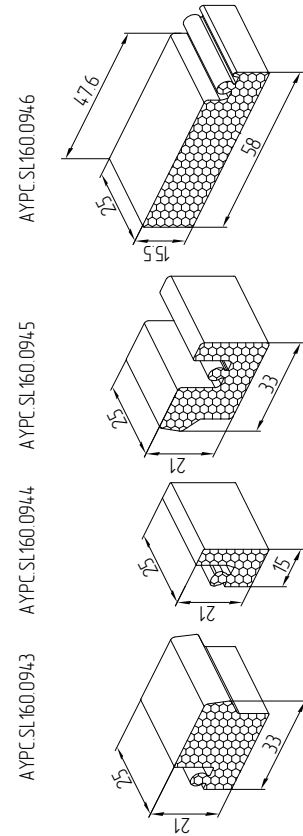

Connectors for the frame profiles of the door types such as A1, A2, A3, B1 and C1 are not provided.

Installation and fixation of supporting profiles in the bottom part of the door

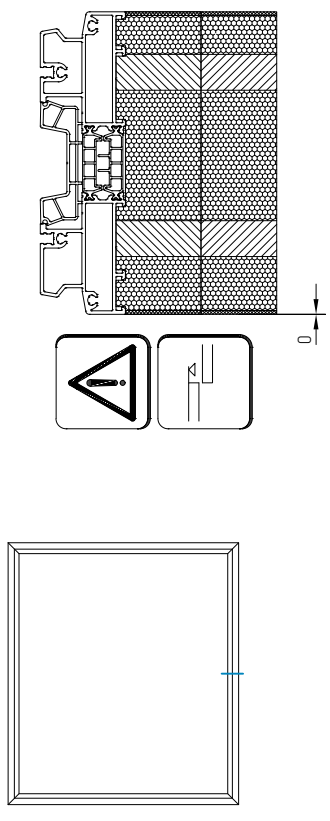

Installation of supporting profiles

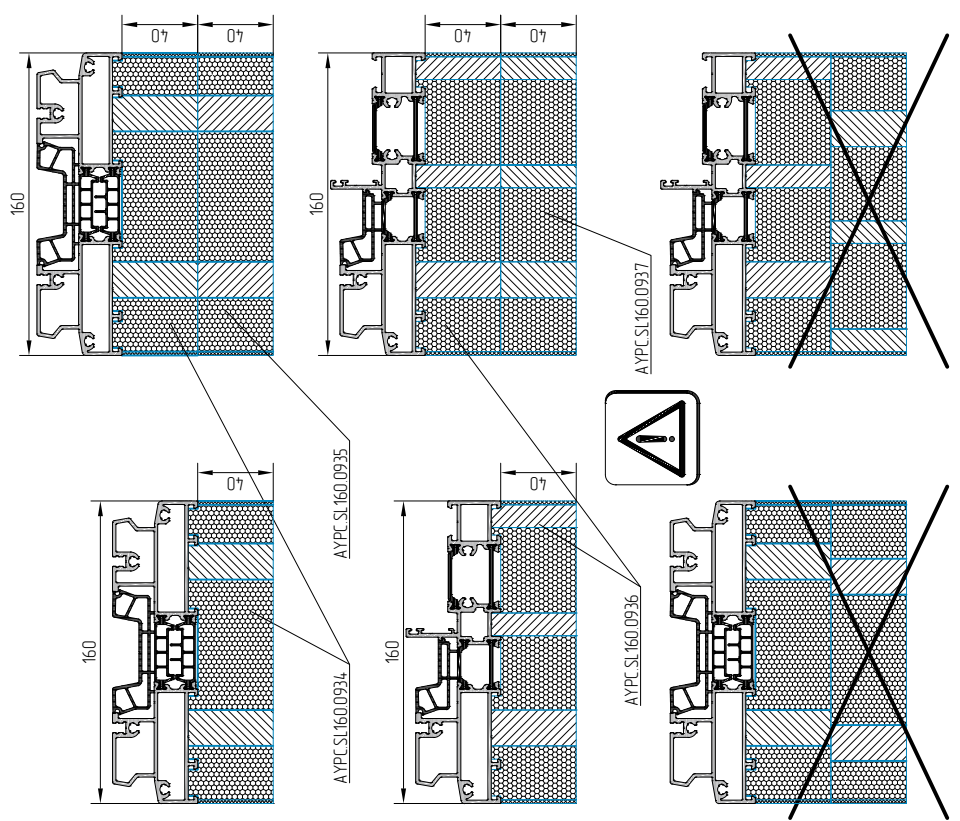

Fixation of supporting profile

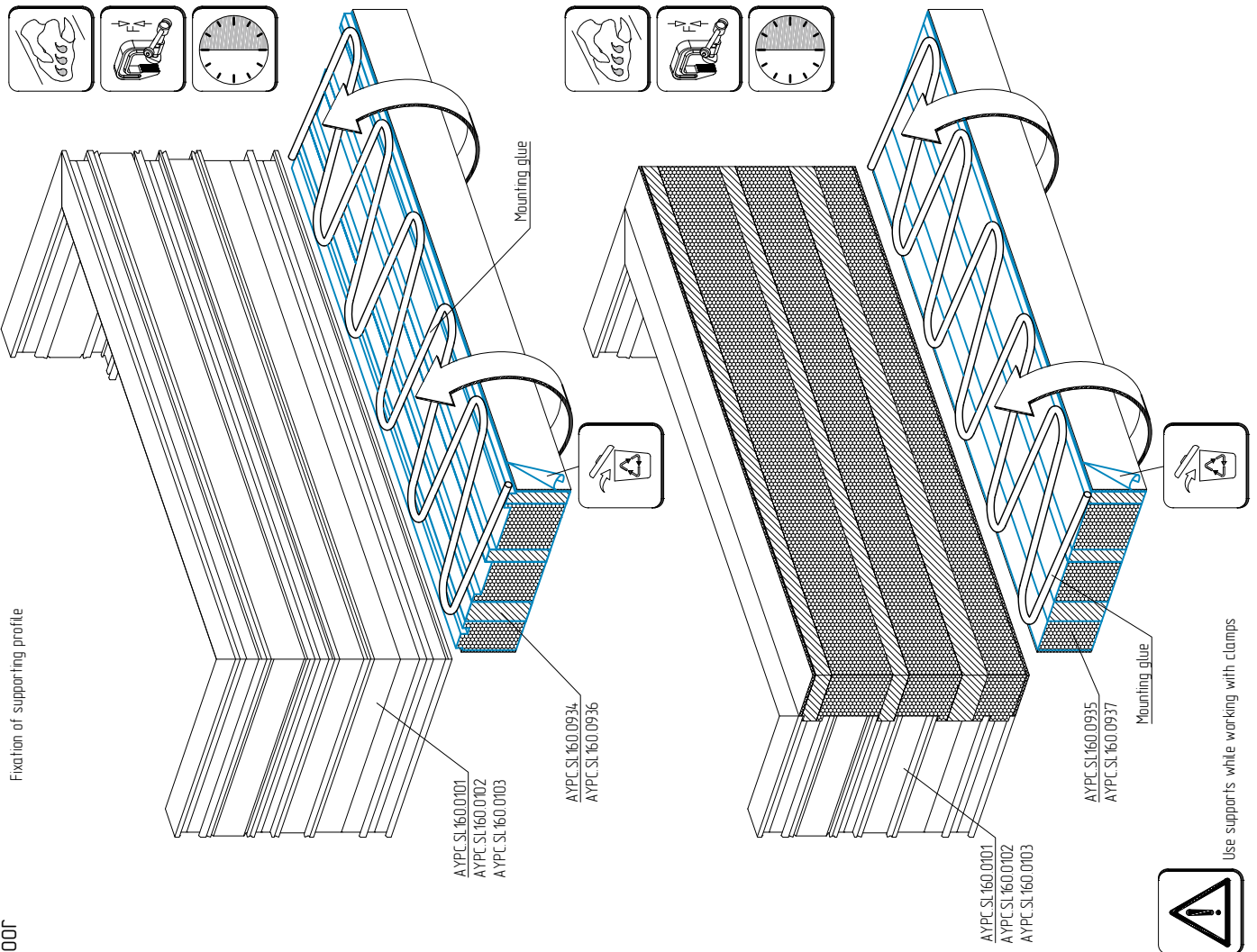

Use supports while working with clamps



ALUTECH ALT SL160

Lifting and sliding constructions

HARDWARE INSTALLATION

Hardware installation

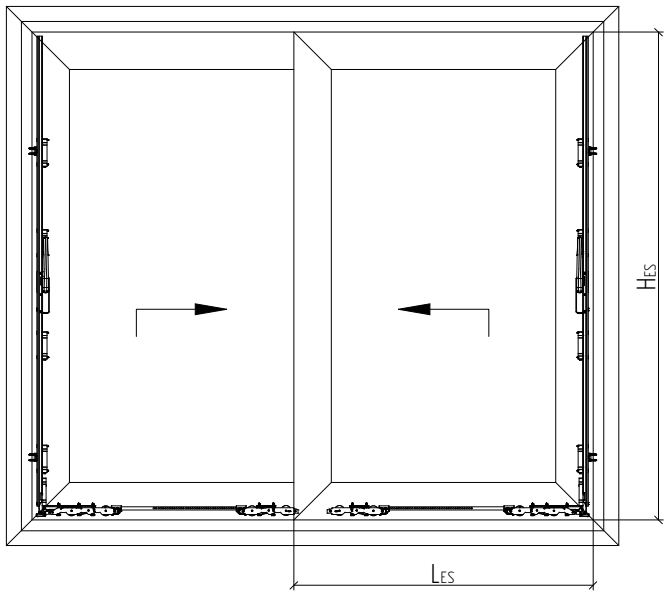
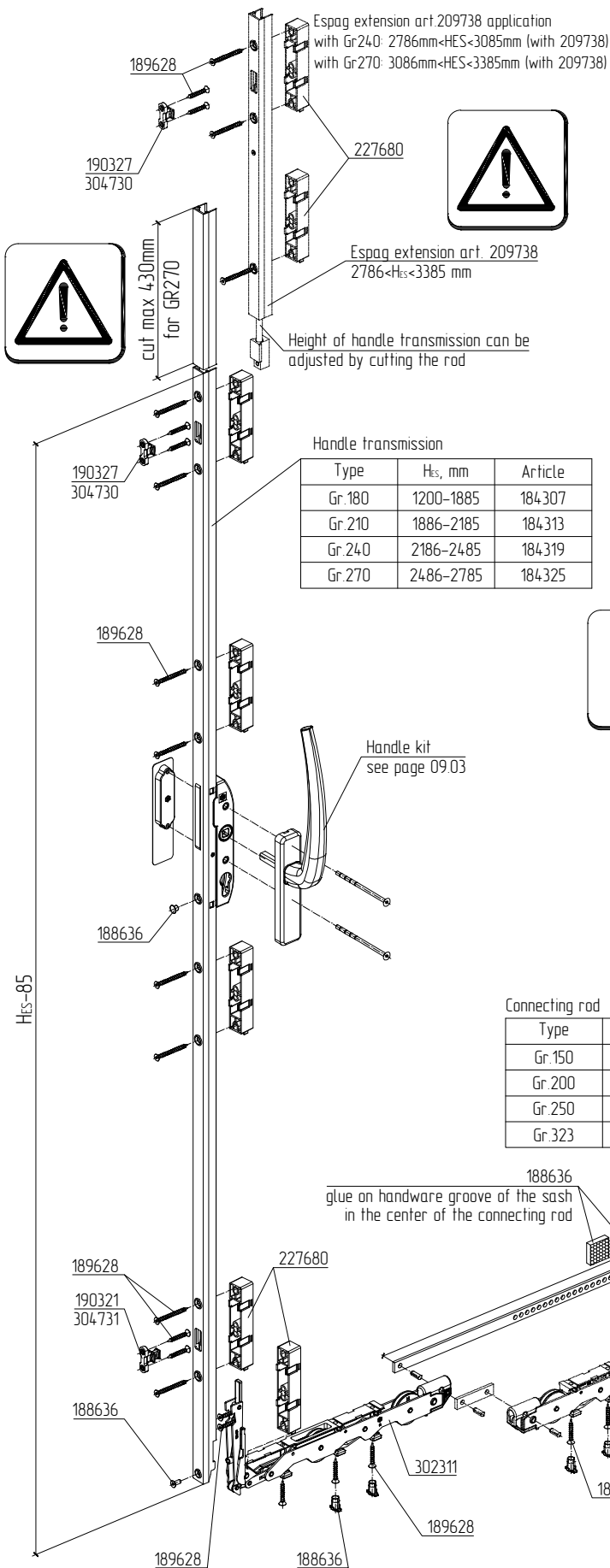

The sash width: min 720 mm (1310 mm with art. 302326) – max 3250 mm
The sash height: min 1200 – max 2786 mm (3385 mm with art. 209738)
Maximum weight of the sash: 330 kg (with art. 302311)
440 kg (art. 302311 + art. 302326)
installation height of the handle: 409 mm (Gr.180 art. 184307) – windows
1009 mm (Gr.210, Gr.240, Gr.270) – doors

Type		Gr.180	Gr.210	Gr.240	Gr.270
	190327 / 304730*	1.2	1.3	1	
	190321 / 304731* (night vent)				
		N, pcs			

* in case of using of coupling profile, it is allowed to install only 190327 and 190321



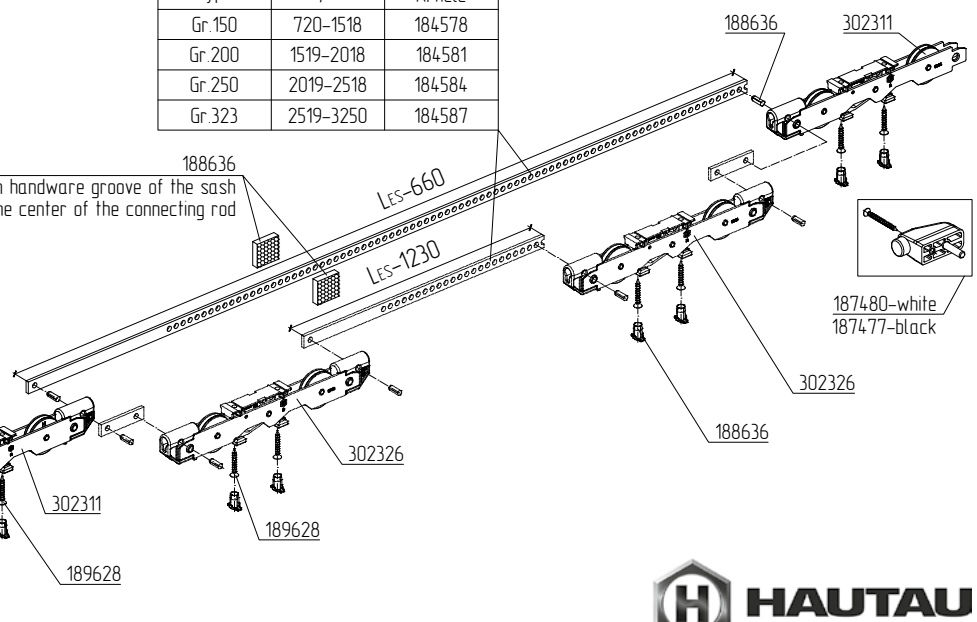

Connecting rod

Type	Les, mm	Article
Gr.150	720-1518	184578
Gr.200	1519-2018	184581
Gr.250	2019-2518	184584
Gr.323	2519-3250	184587

188636
glue on hardware groove of the sash in the center of the connecting rod

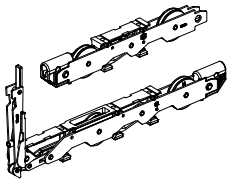
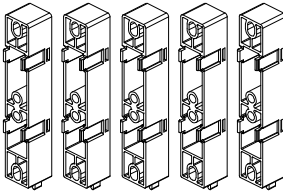
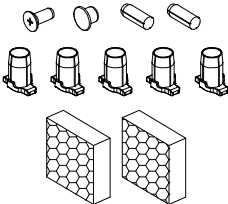
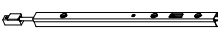
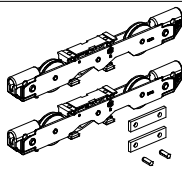
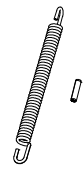
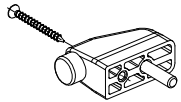
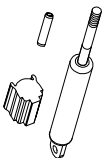

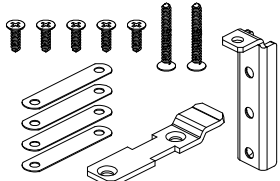
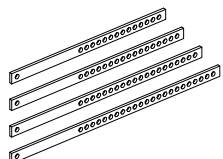
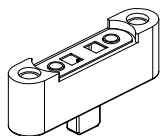
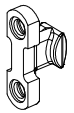
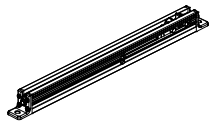
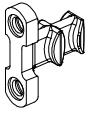
Hardware list

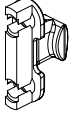
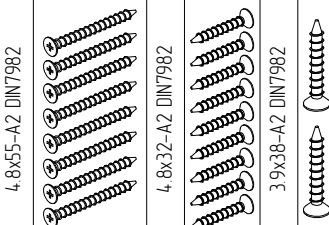
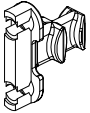
Image	Article	Code	Image	Article	Code
Bogie kit 330 kg			Packers 21 mm		
	302311	13171500		227680	13174600
Fastening kit			Espag extension		
	188636	13171600		209738	13174200
Tandem bogie 440 kg			Microlift		
	302326	13173000		<200 κz 239654 >200 κz 239657	13171800 13173100
Stop			Gas lift		
	RAL9016 187480 RAL9005 187477	13173621 13172832		>120 kg 247164	13174700
Handle kit			Mounting kit of Comfort Close mechanism		
	180 184307 210 184313 240 184319 270 184325	13173200 13173300 13173400 13171700		302235	13270600
Connecting rod			Locking bolt of Comfort Close mechanism		
	150S+ 184578 200S+ 184581 250S+ 184584 323S+ 184587	13172700 13172900 13171900 13173500		300380	13175000
Locking bolt 9.5s+			Comfort Close mechanism		
	190327	13178800		<200 kg 300359 >200 kg 300360	13174800 13174900
Locking bolt (night vent) 9.5s+			Handle fastening kit		
	190321	13270300		225496	13179700
Locking bolt with positioning 9.5s+			Roller fastening kit		
	304730	13270400		189628	13172100
Locking bolt (night vent) with positioning 9.5s+					
	304731	13270500			

Handle installation on lift and slide sashes

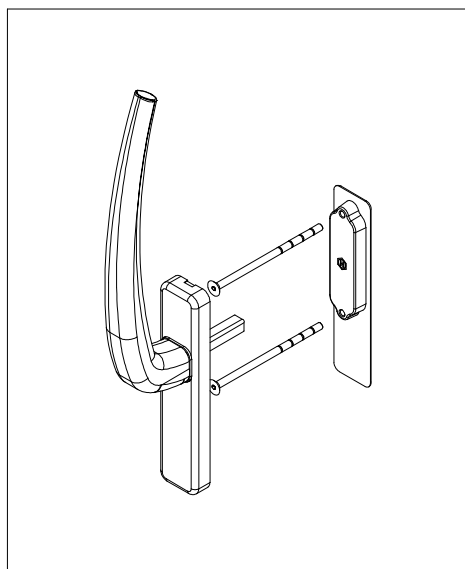

Colour	Code	Article
RAL9016	13173721	234410
RAL9005	13172632	234416

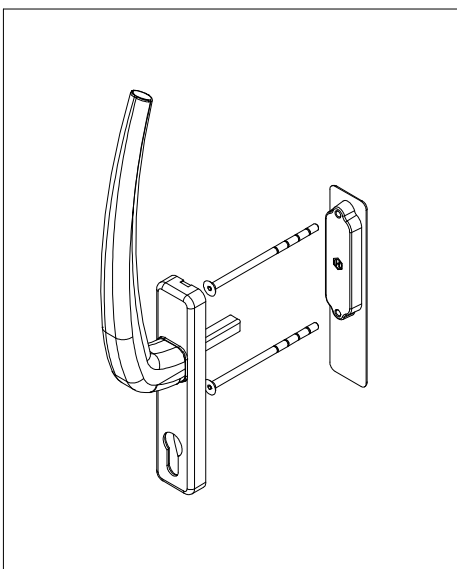

Colour	Code	Article
RAL9016	13173821	234431
RAL9005	13173932	234437

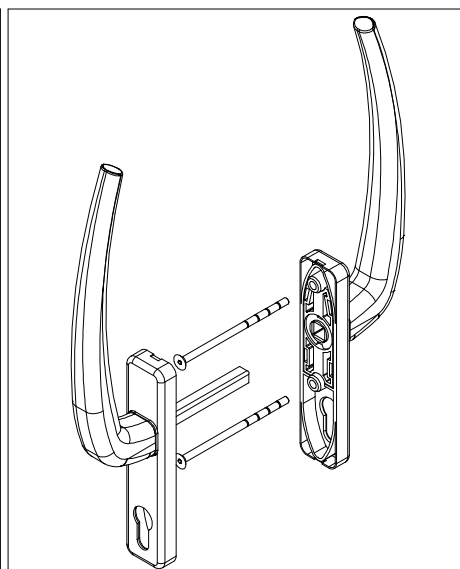

Colour	Code	Article
RAL9016	13172421	185179
RAL9005	13172432	193621

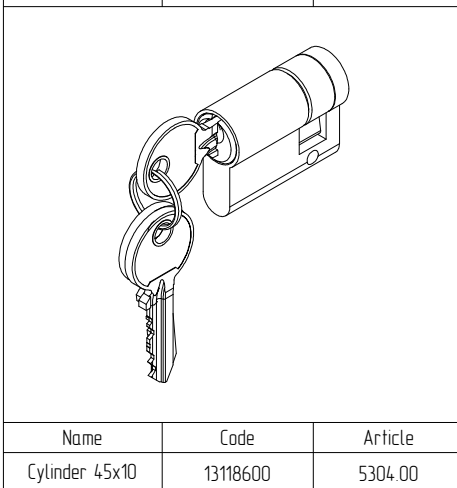
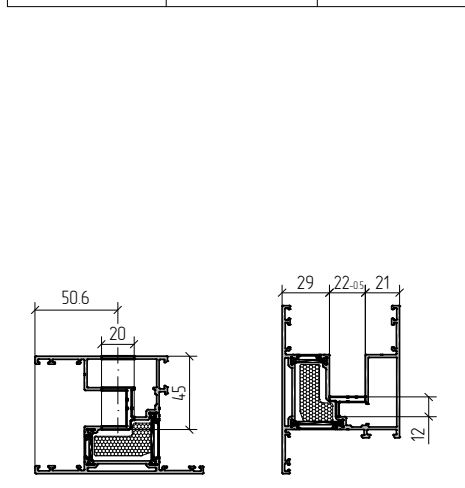

Name	Code	Article
Cylinder 45x10	13118600	5304.00

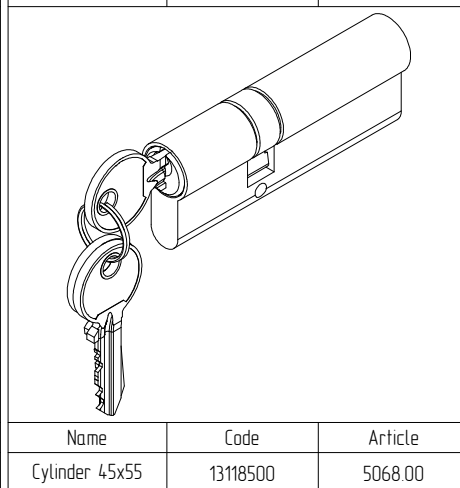

Name	Code	Article
Cylinder 45x55	13118500	5068.00

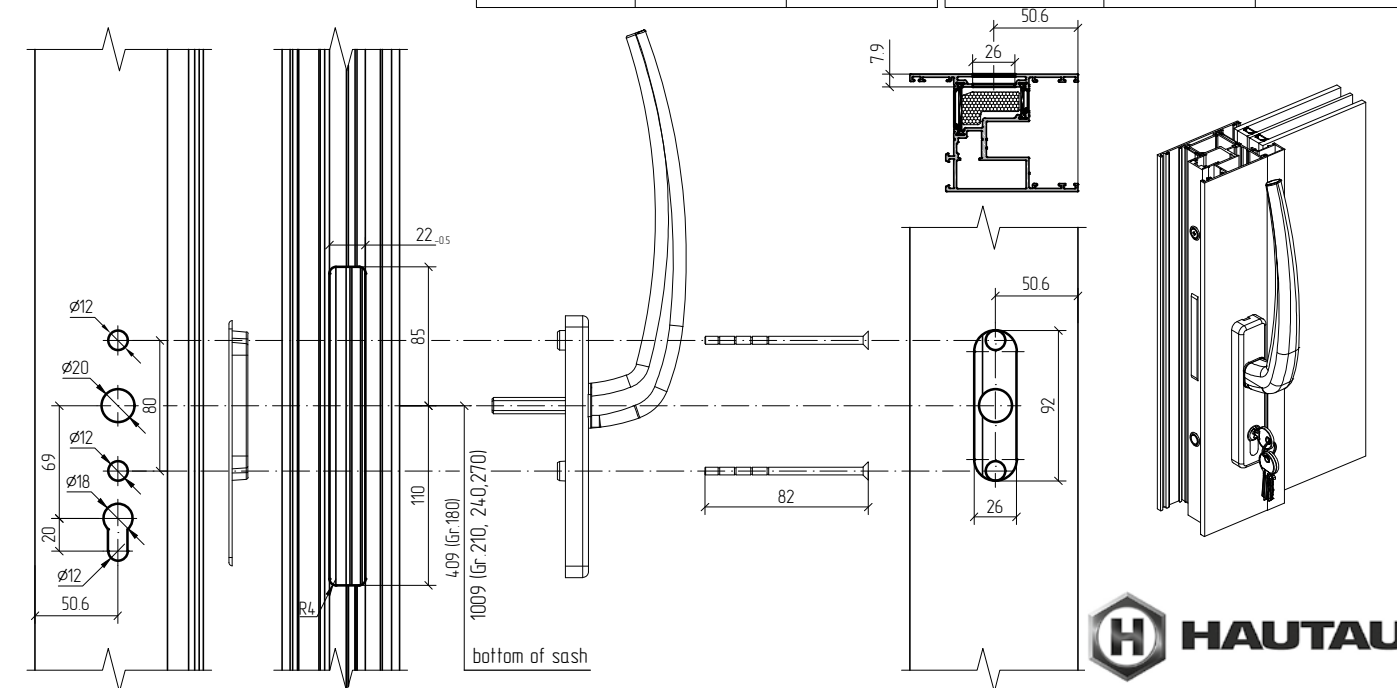

Stop installation on lift and slide sashes

Kit 187480 (white), 187477 (black)

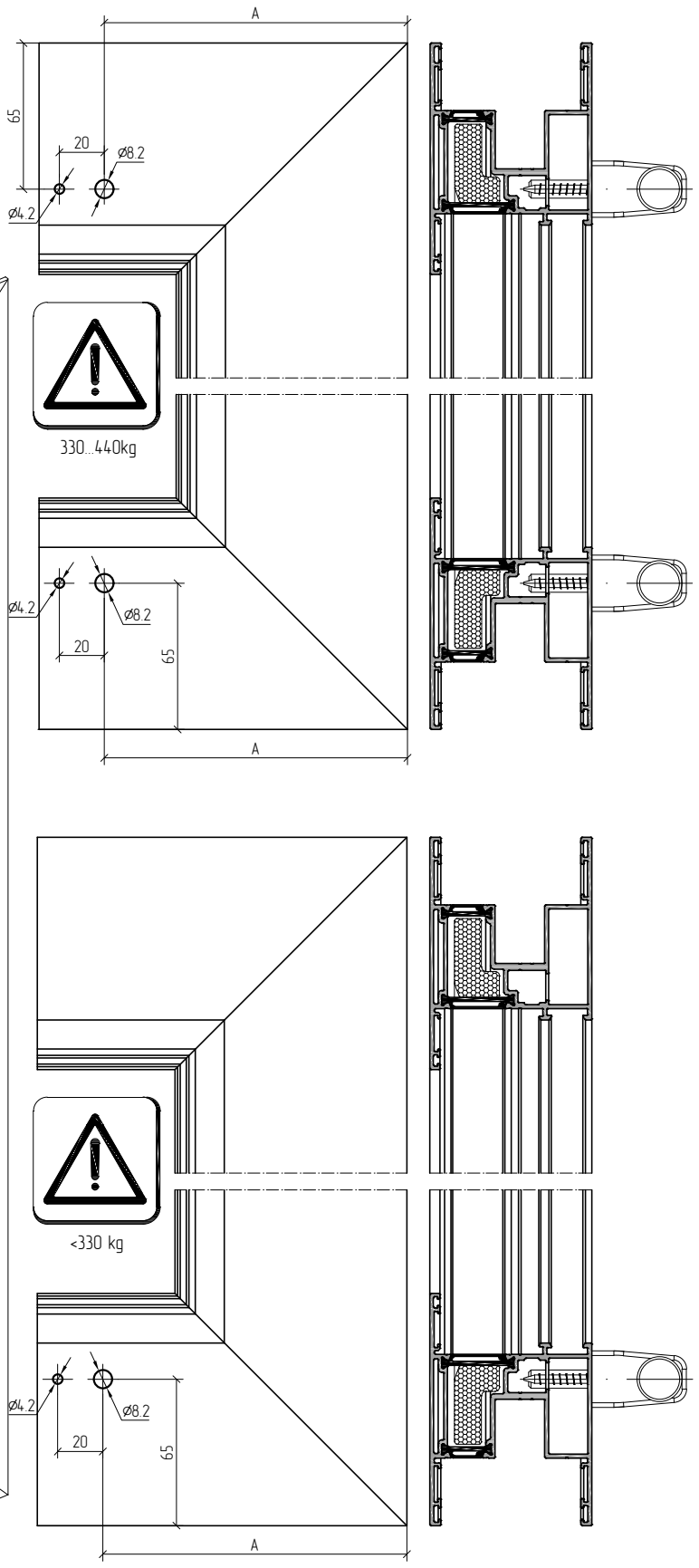
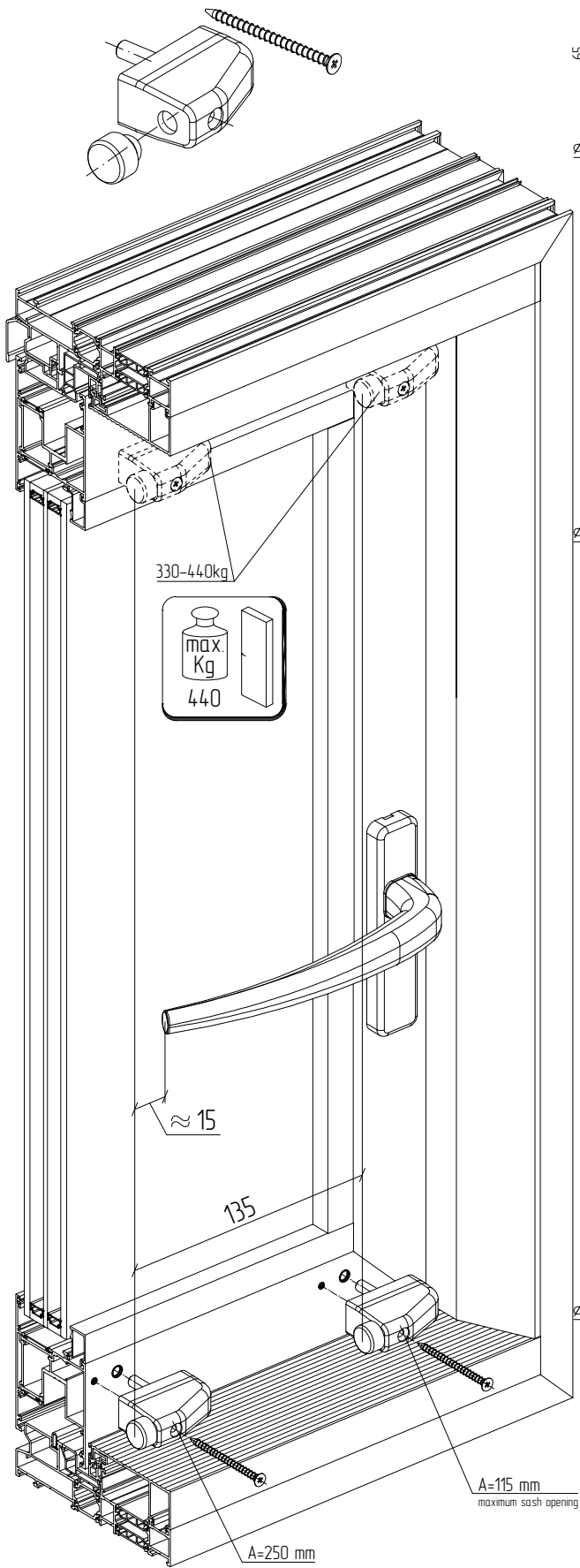

Installation of microlift/glass lift on lift and slide sashes

<200 kg

>200 kg

>120 kg

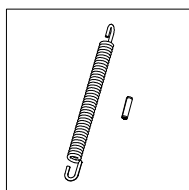

239654

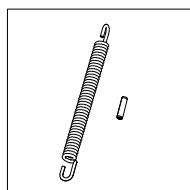

239657

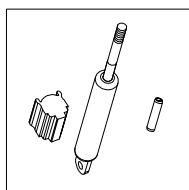

247164



Hes >1886 mm

Handle transmission

Type	Article
Gr. 210	184313
Gr. 240	184319
Gr. 270	184325

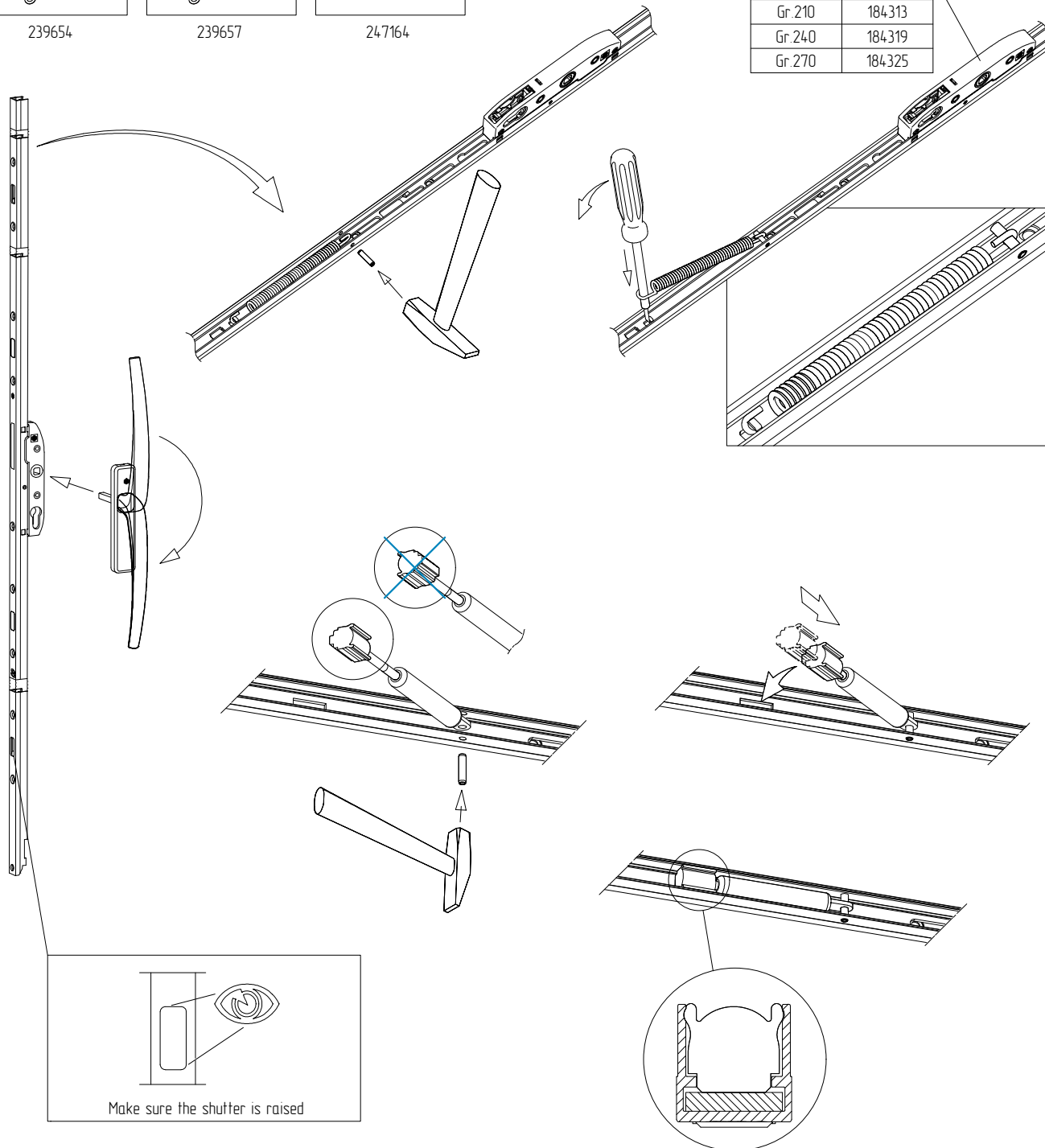

Make sure the shutter is raised

01

02

03

04

05

06

07

08

09

10

Handle installation on passive sash

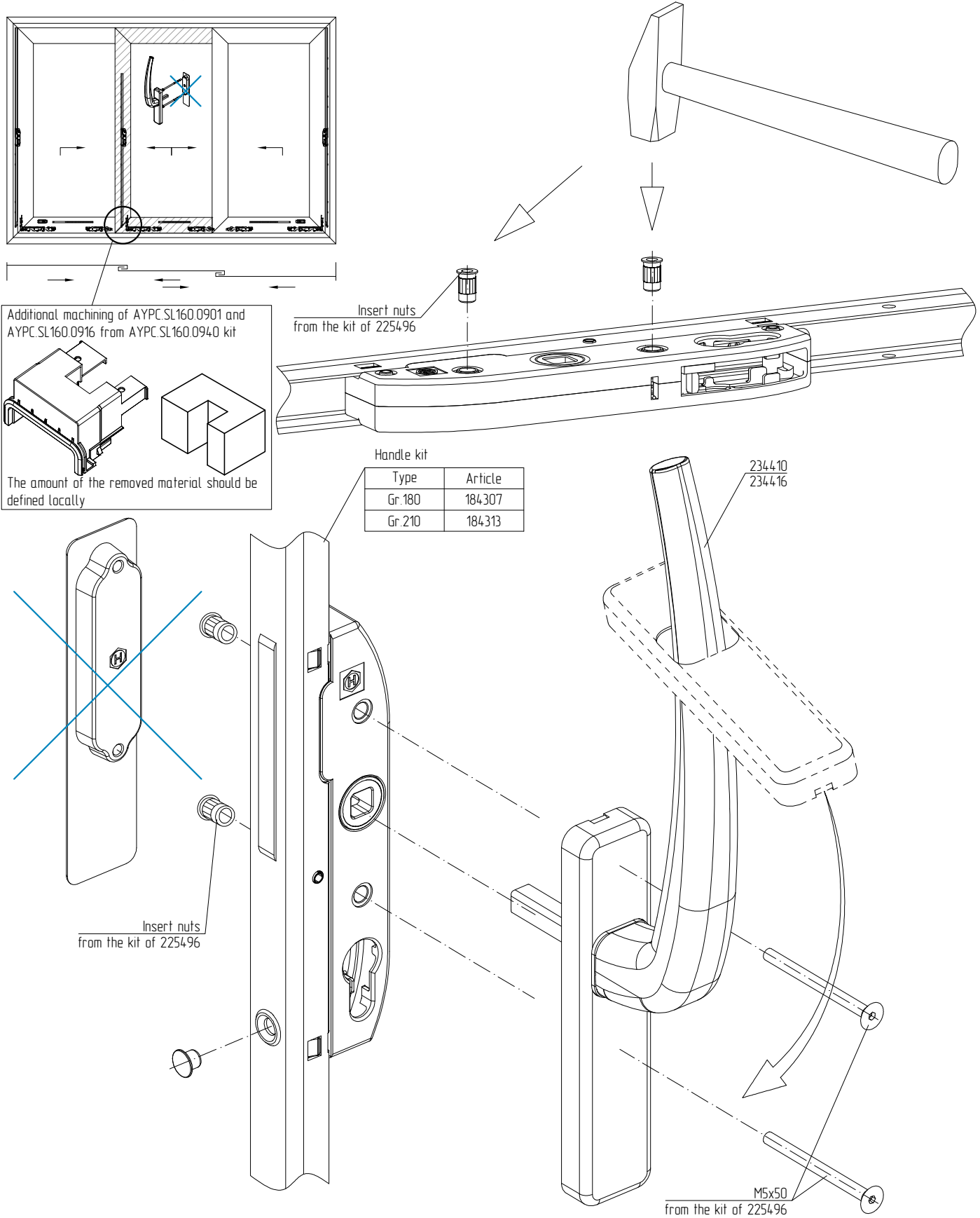

Installation of locking elements and handle transmission extension

Type	A1, mm	A2, mm	B1, mm	B2, mm	C1, mm	C2, mm	D1, mm	D2, mm	X, mm
Gr.180	-	-	588	612	988	1012	-	-	-
Gr.210	738	762	1188	1212	1588	1612	-	-	-
Gr.240					1888	1912	H _{HC} -282	H _{HC} -306	H _{HC} -684
Gr.270					2188	2212			

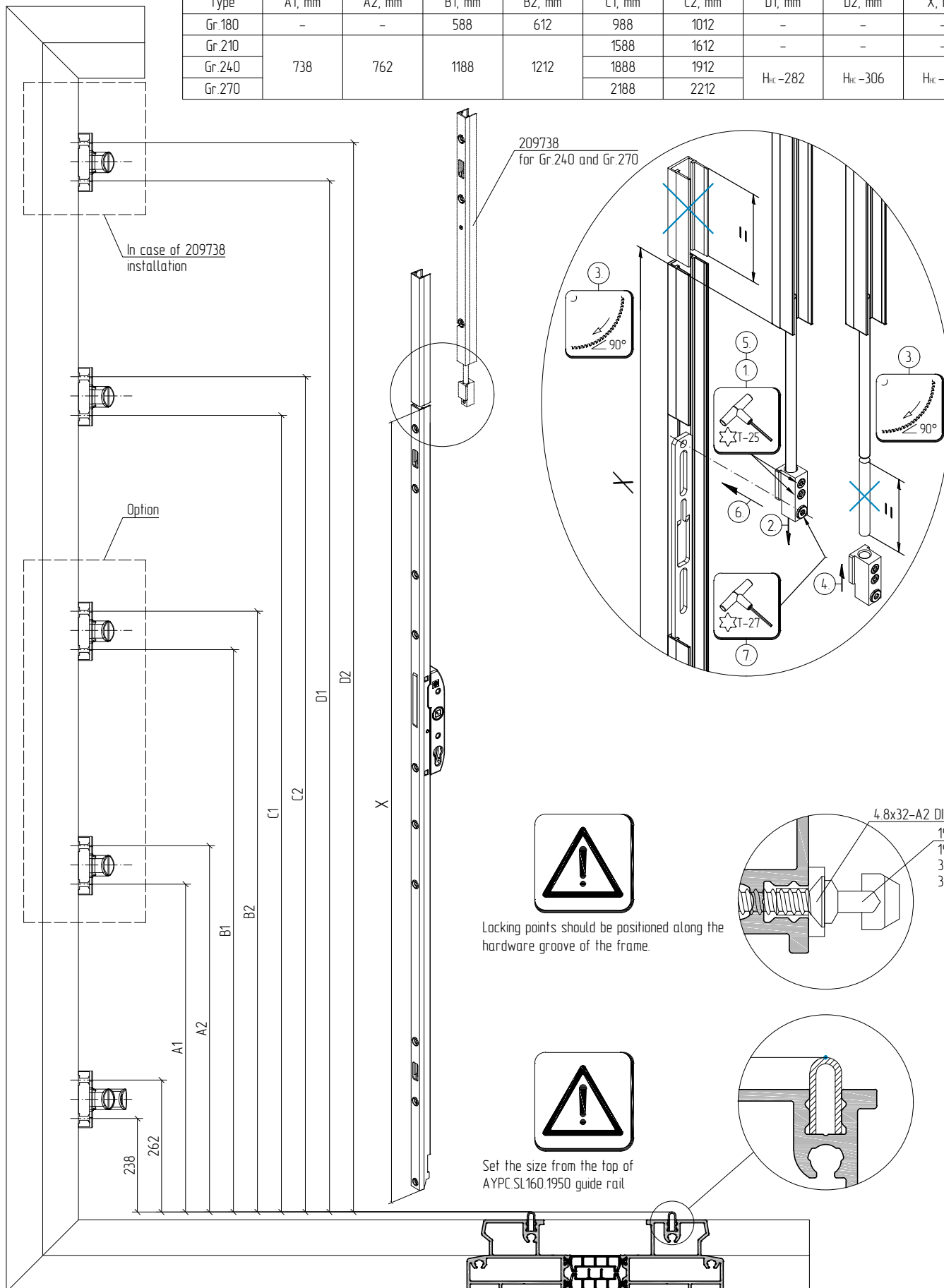

Installation of locking elements on AYPC.SL160.0504 coupling profile



Type	A1, mm	A2, mm	B1, mm	B2, mm	C1, mm	C2, mm	D1, mm	D2, mm
Gr.180	-	-	602	626	1002	1026	-	-
Gr.210	752	776	1202	1226	1602	1626	-	-
Gr.240					1902	1926	H _{HC} -268	H _{HC} -292
Gr.270					2202	2226		

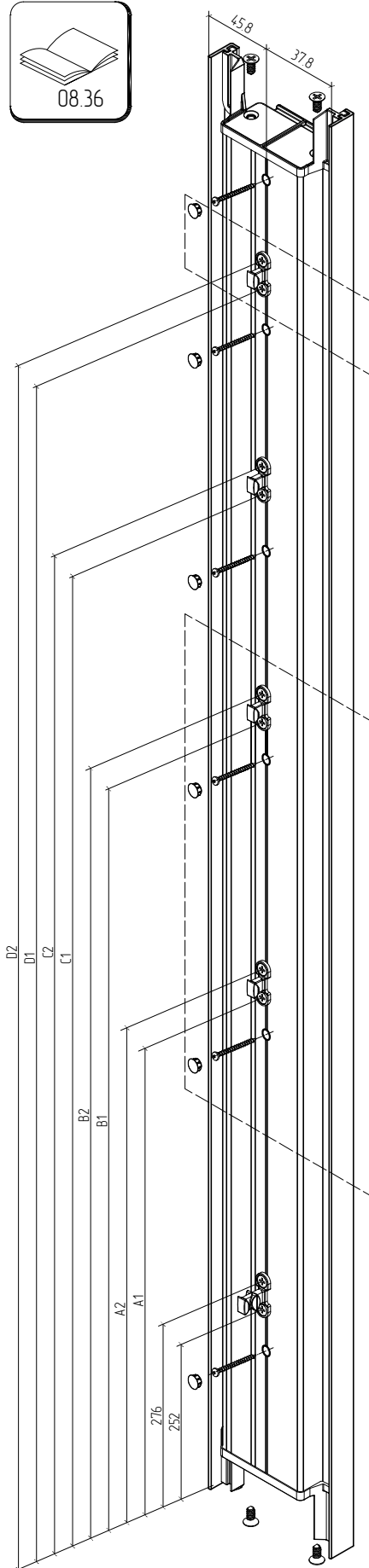

In case of 209738 installation

Sequence of opening steps for the door with coupling profile

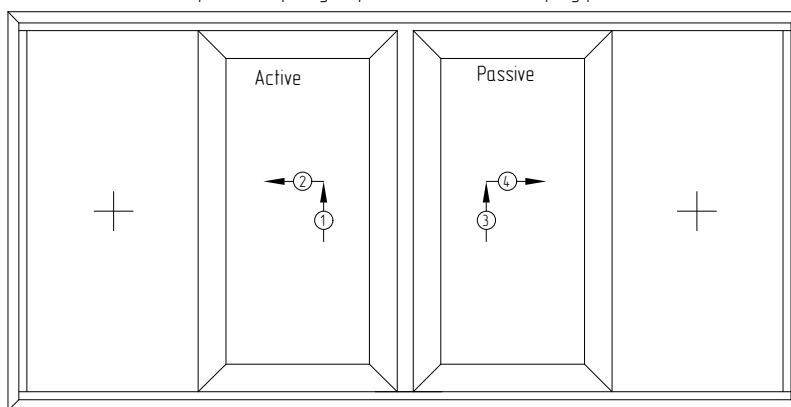

Sequence of closing steps for the door with coupling profile

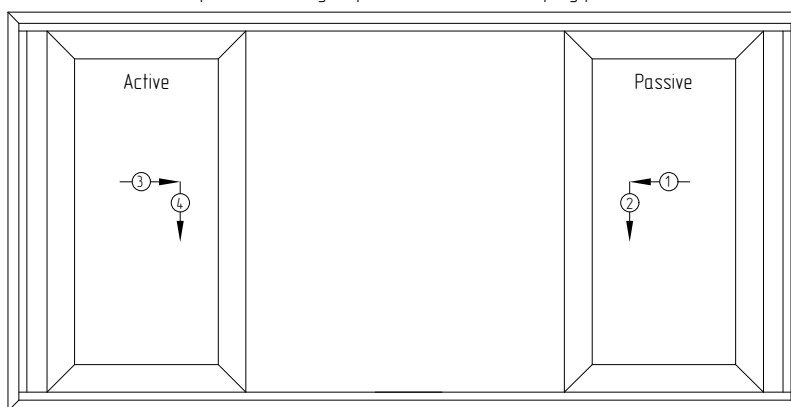

Option



For coupling profile it is allowed to use 190327 and 190321 locking bolts only.

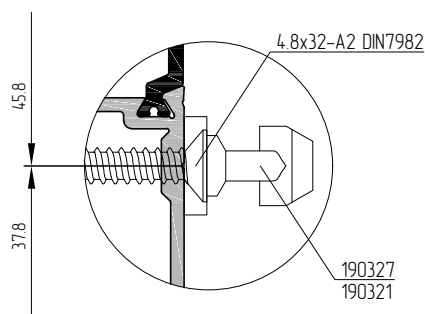

Locking elements installation on AYPC.SL160.0813 frame ledge profile



Type	A1, mm	A2, mm	B1, mm	B2, mm	C1, mm	C2, mm	D1, mm	D2, mm
Gr.180	-	-	602	626	1002	1026	-	-
Gr.210	752	776	1202	1226	1602	1626	-	-
Gr.240					1902	1926	H _{HC} -268	H _{HC} -292
Gr.270					2202	2226		

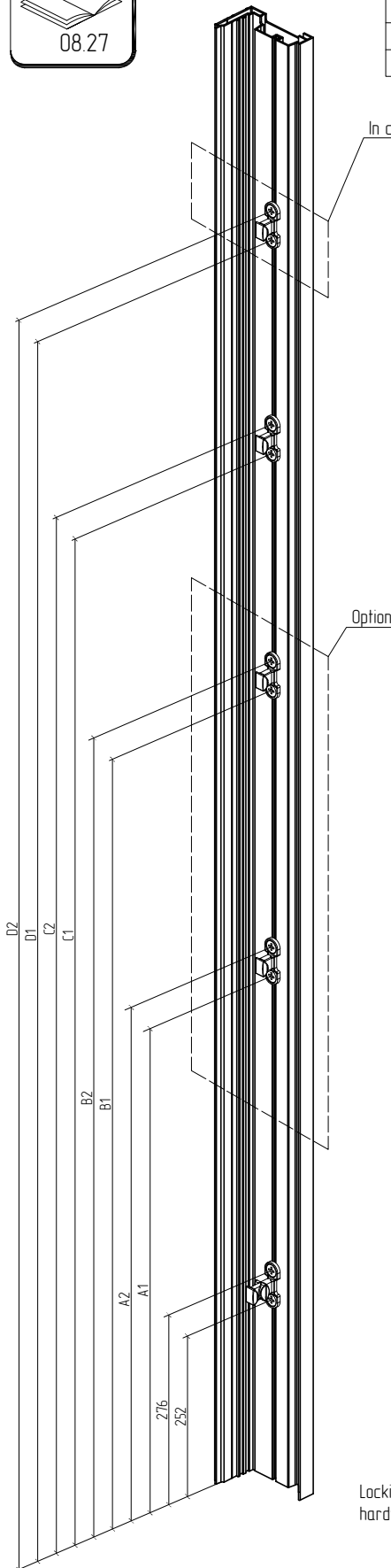

In case of 209738 installation



Installation of one-sided handle can be possible only from the inside of the premises.

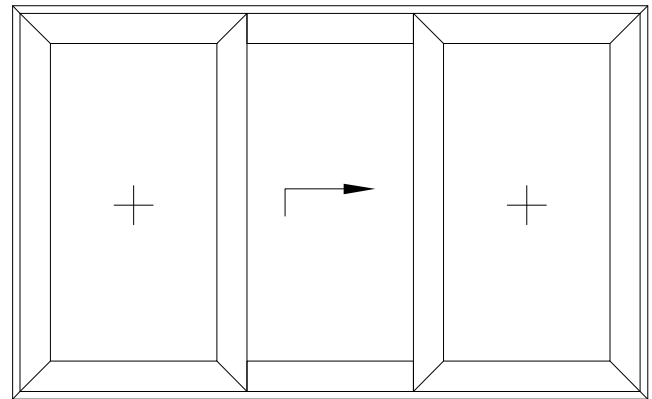

Option

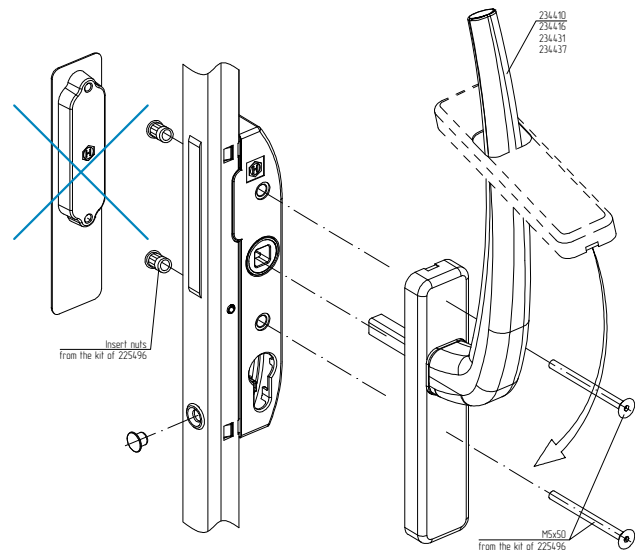
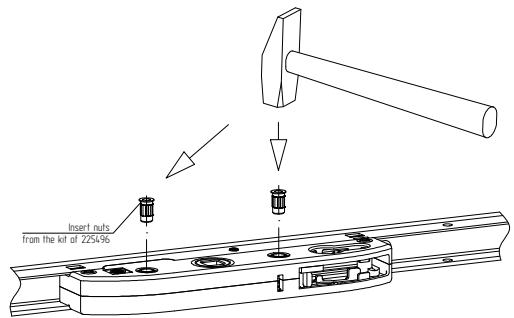

Locking points should be positioned along the hardware groove of the frame.

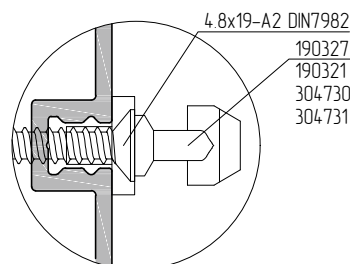

Installation of "Comfort Close" kit on lift and slide doors

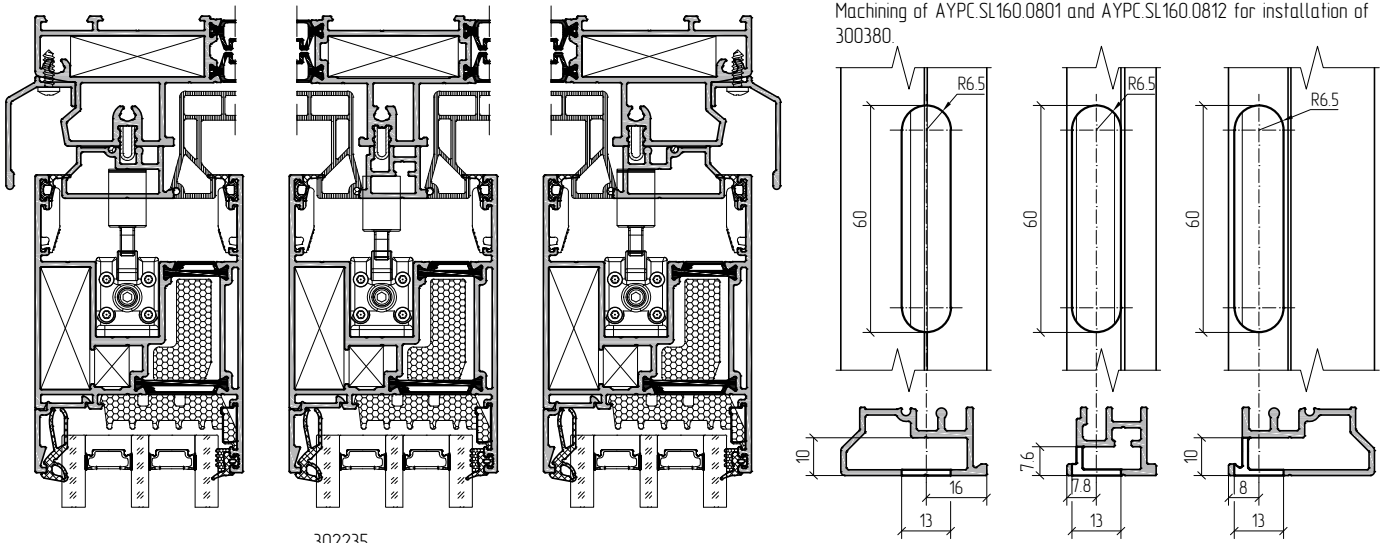

<200 kg - 300 kg
>200 kg - 300360.

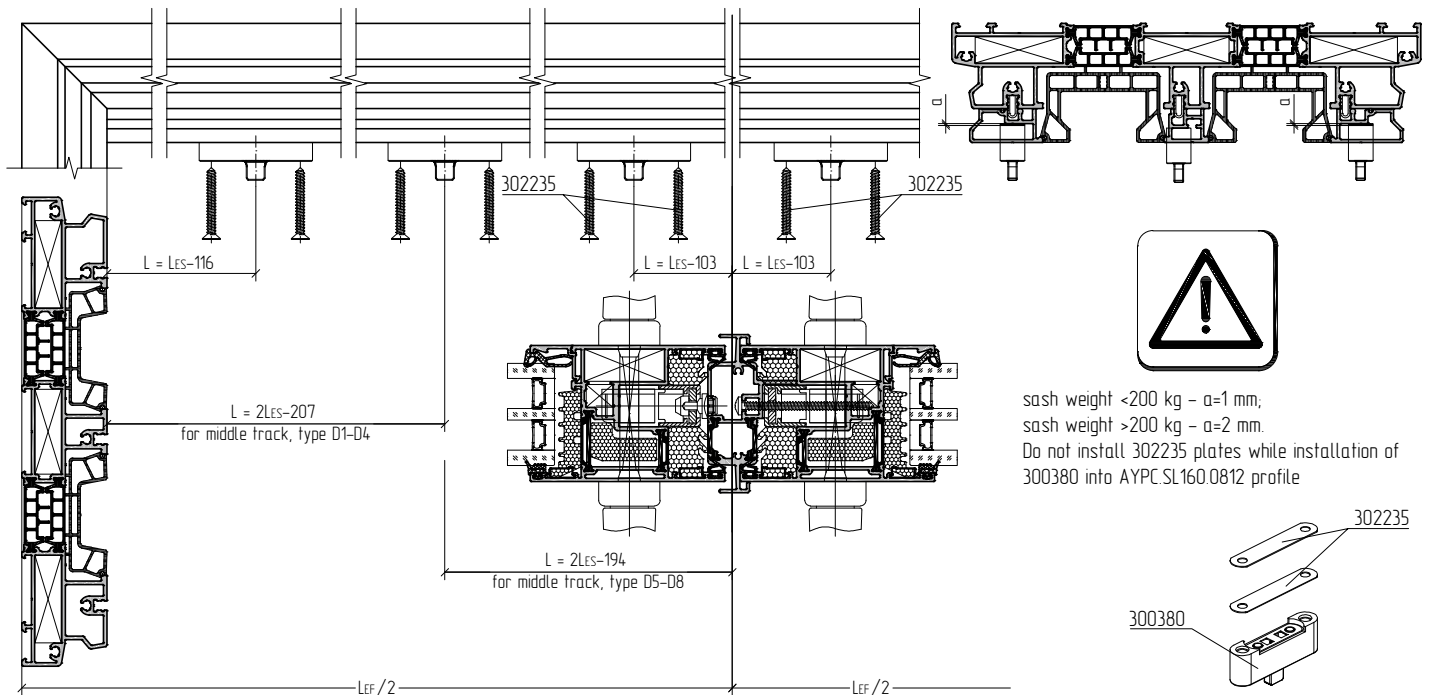
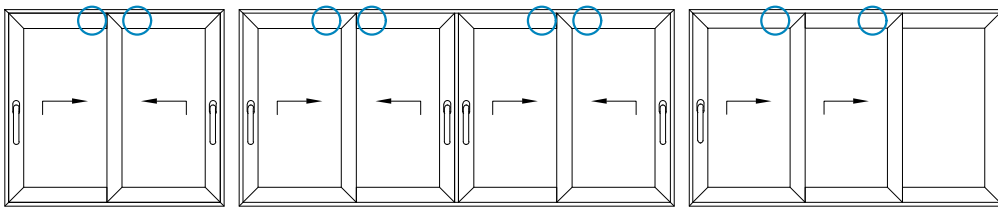
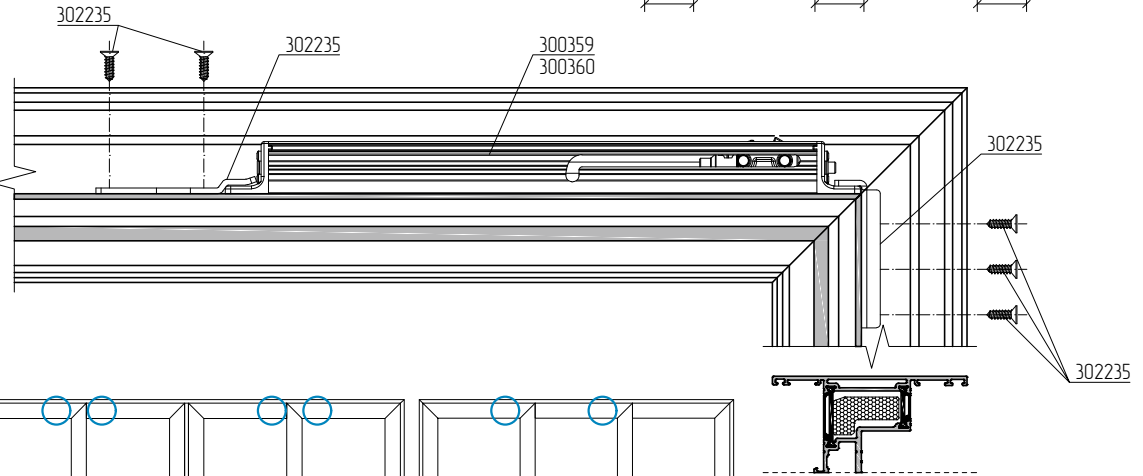

Example of hardware fitting for lift and slide sashes

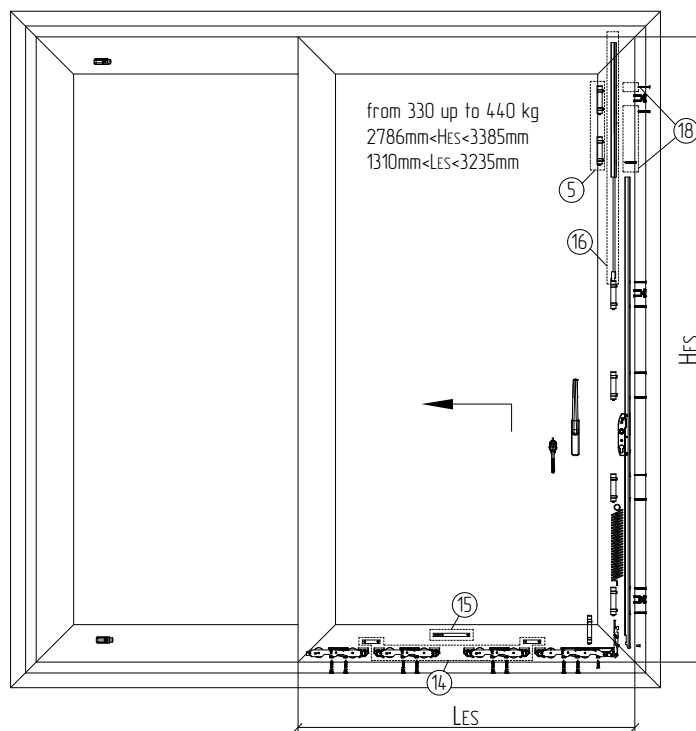
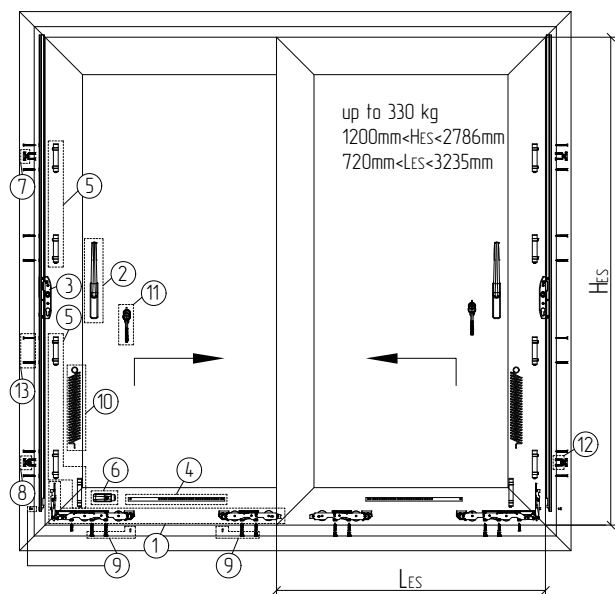

Article	Name	Position	1..
Hardware			
302311	Bogie kit 330kg	1	2 kits
see page 09.03	Handle kit	2	2 kits
see page 09.01	Handle transmission	3	2 kits
see page 09.01	Connecting rod	4	2 pcs
227680	Packers 21 mm	5	2 kits
see page 09.04	Stop	6	1 kit
see page 09.01	Hook	7	2 pcs
see page 09.01	Locking bolt (night vent)	8	2 pcs
188636	Fastening kit	9	2 kits
see page 09.05	Microlift	10	2 kits
see page 09.03	Cylinder	11	2 kits
189628	Roller fastening kit	12, 13	2 kits

Article	Name	Position	1..
Hardware			
302311	Bogie kit 330 kg	1	1 kit
302326	Additional roller kit 440 kg	14	1 kit
see page 09.03	Handle kit	2	1 kit
see page 09.01	Handle transmission	3	1 kit
see page 09.01	Connecting rod	15	1 pcs
227680	Packers 21 mm	5	2 kits
see page 09.04	Stop	6	2 kits
see page 09.01	Hook	7	2 pcs
see page 09.01	Locking bolt (night vent)	8	1 pcs
188636	Fastening kit	9	2 kits
209738	Espag extension	16	1 kit
see page 09.05	Microlift >200 kg	10	1 kit
see page 09.03	Cylinder	11	1 kit
189628	Roller fastening kit	12, 13, 18	3 kits



Handle transmission fitting recommendations:
Gr240: 2786mm < HES < 3085mm (with 209738)
Gr270: 3086mm < HES < 3385mm (with 209738)



Example of hardware fitting for lift and slide doors with coupling profile

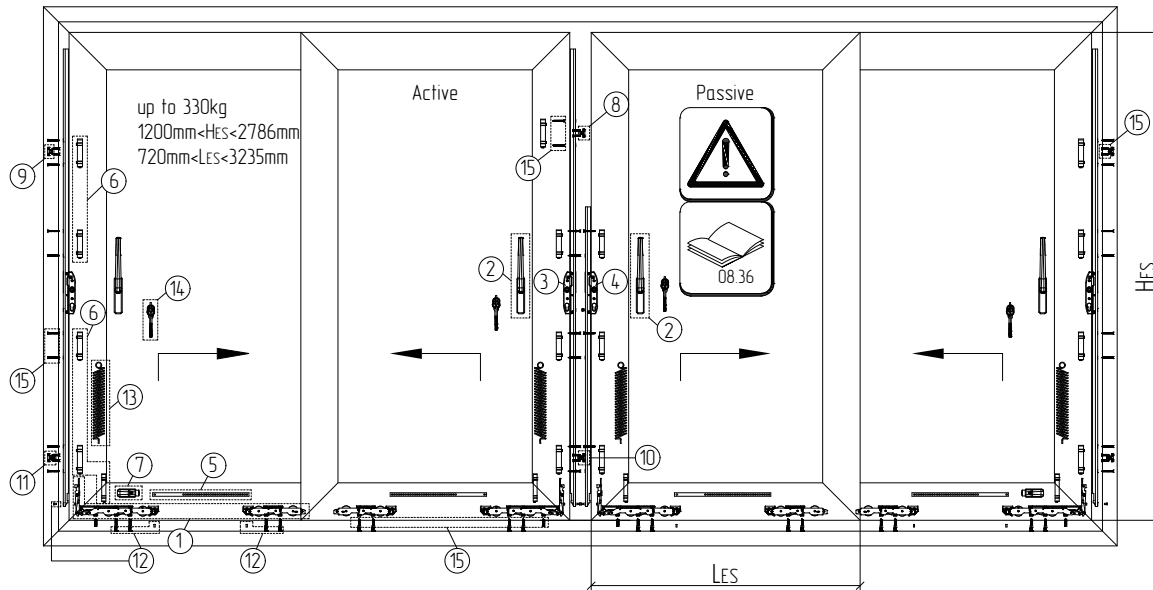

Article	Name	Position	1..
Hardware			
302311	Bogje kit 330 kg	1	4 kits
see page 09.03	Handle kit	2	4 kits
see page 09.01	Handle transmission	3	3 kits
184313	Espag	4	1 kit
see page 09.01	Connecting rod	5	4 pcs
227680	Packers 21 mm	6	4 kits
see page 09.04	Stop	7	2 kits
190327	Locking bolt	8	1 pc
304730	Hook	9	2 pcs
190321	Locking bolt (night vent)	10	1 pc
304731	Locking bolt (night vent)	11	2 pcs
188636	Fastening kit	12	4 kits
see page 09.05	Microlift	13	4 kits
see page 09.03	Cylinder	14	4 kits
189628	Roller fastening kit	15	4 kits

Example of hardware fitting for lift and slide doors with coupling profile

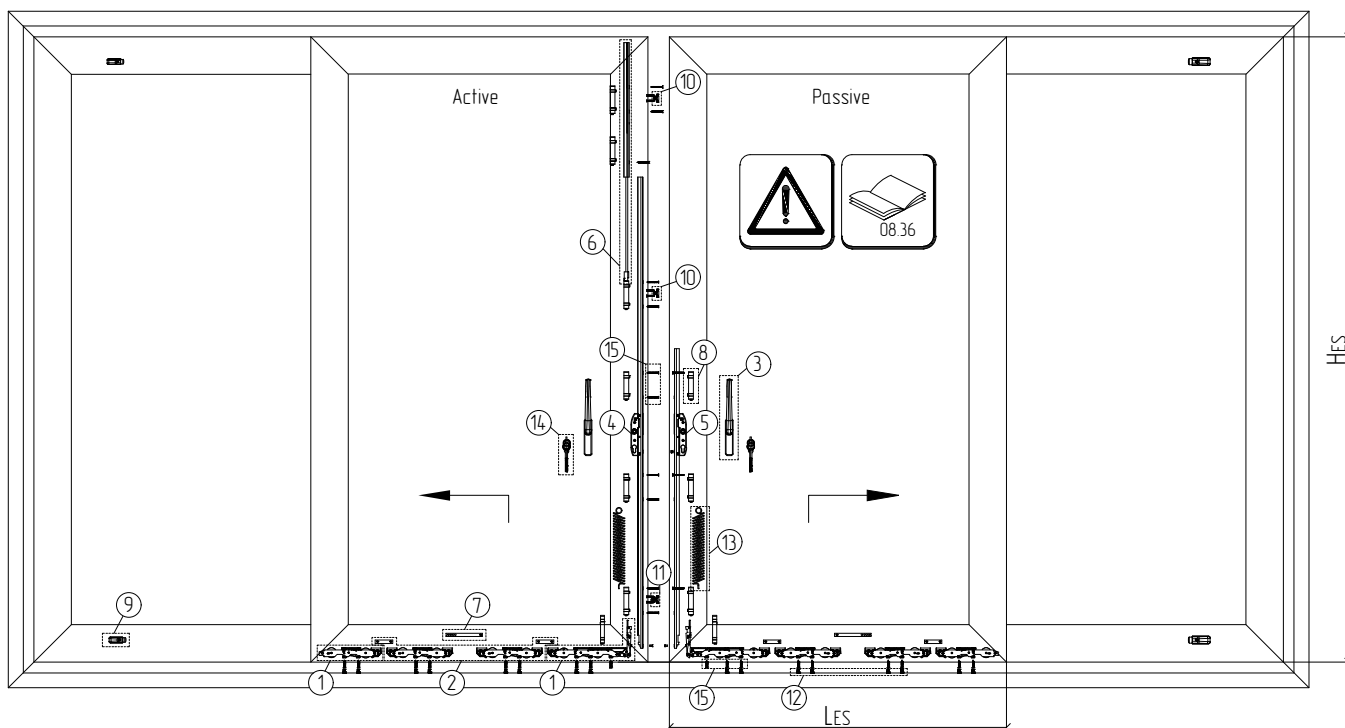

from 330 up to 440 kg
Gr270: 3086mm<Hes<3385mm (with 209738)
Gr240: 2786mm<Hes<3085mm (with 209738)
1310mm<Les<3235mm



Article	Name	Position	1...
Hardware			
302311	Bogie kit 330 kg	1	2 kits
302326	Tandem bogie 440 kg	2	2 kits
see page 09.03	Handle kit	3	2 kits
see page 09.01	Handle transmission	4	1 kit
184313	Espag	5	1 kit
209738	Espag extension	6	1 kit
see page 09.01	Connecting rod	7	2 pcs
227680	Packers 21 mm	8	3 kits
see page 09.04	Stop	9	4 kits
190327	Locking bolt	10	2 pcs
190321	Locking bolt (night vent)	11	1 pc
188636	Fastening kit	12	4 kits
see page 09.05	Microlift	13	2 kits
see page 09.03	Cylinder	14	2 kits
189628	Roller fastening kit	15	5 kits



Example of hardware fitting for lift and slide sashes

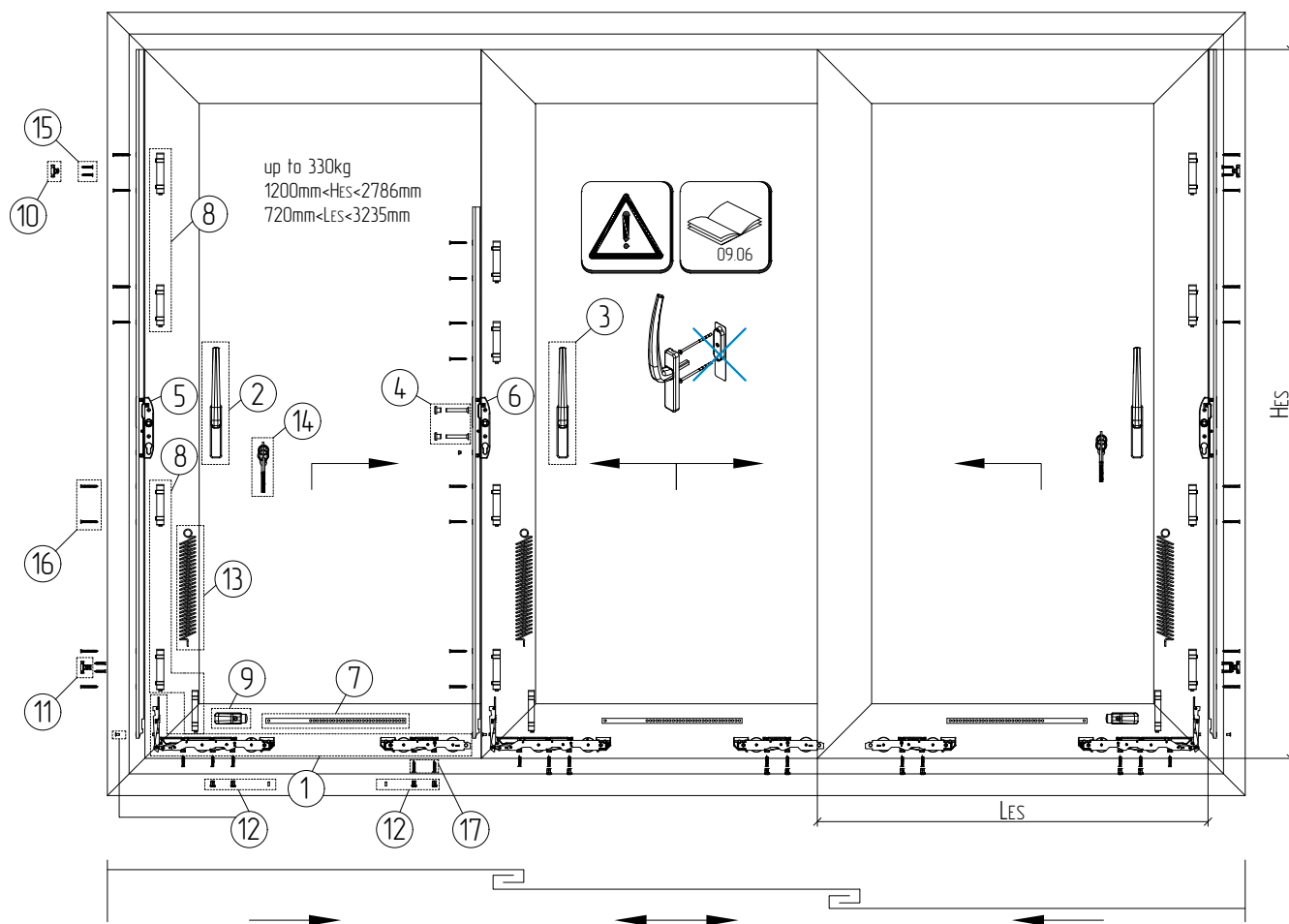

Article	Name	Position	1..
Hardware			
302311	Bogie kit 330 kg	1	3 kits
see page 09.03	Handle kit	2	2 kits
234410 234416	Handle kit	3	1 kit
225496	Handle fastening kit	4	1 kit
see page 09.01	Handle transmission	5	2 kits
see page 09.06		6	1 kit
see page 09.01	Connecting rod	7	3 pcs
227680	Packers 21 mm	8	3 kits
see page 09.04	Stop	9	2 kits
see page 09.01	Hook	10	2 pcs
see page 09.01	Locking bolt (night vent)	11	2 pcs
188636	Fastening kit	12	3 kits
see page 09.05	Microlift	13	3 kits
see page 09.03	Cylinder	14	2 kits
189628	Roller fastening kit	15, 16, 17	3 kits

Example of hardware fitting for lift and slide sashes

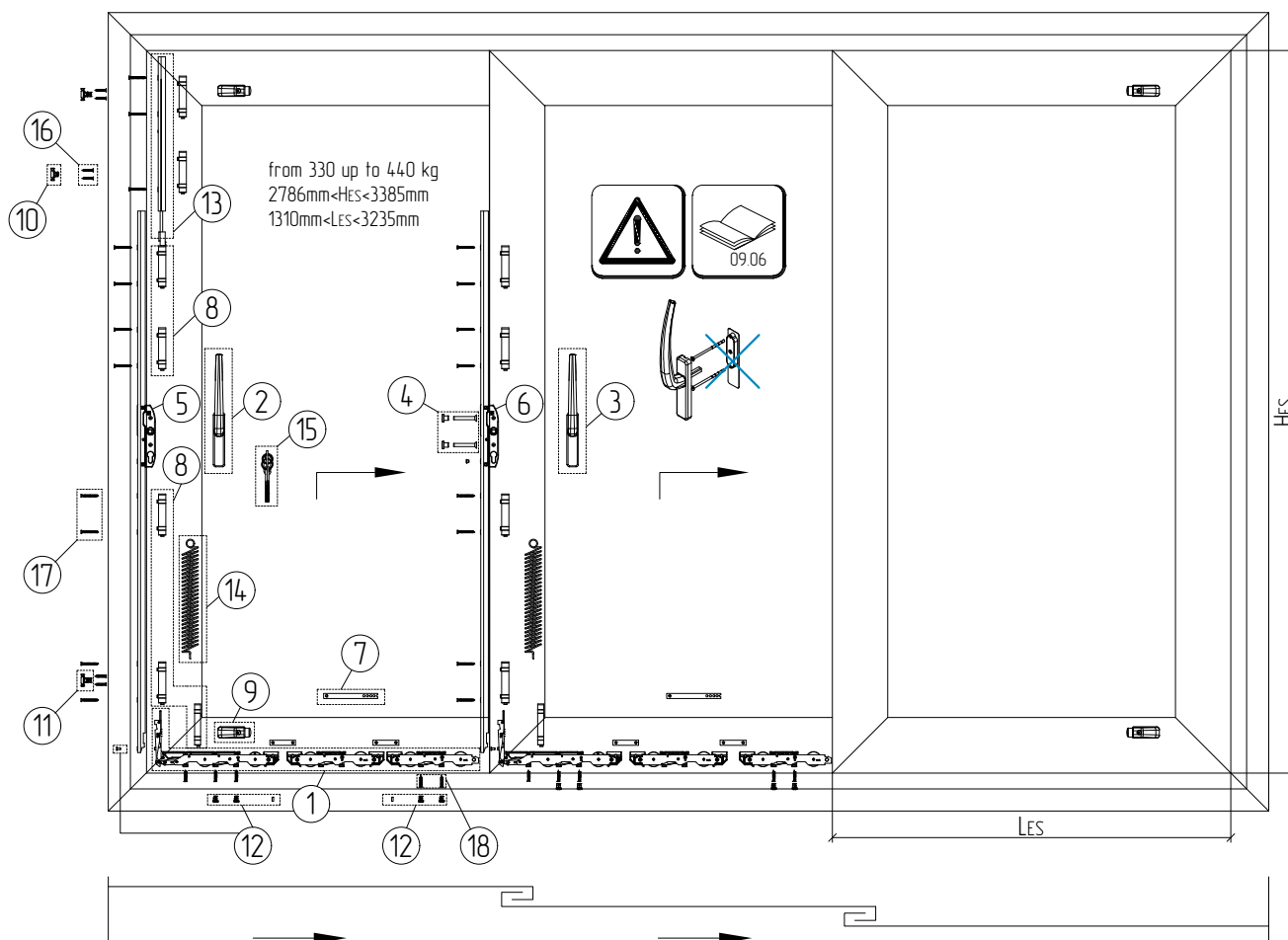

Article	Name	Position	1..
Hardware			
302311	Bogie kit 330 kg	1	2 kits
302326	Tandem bogie 440 kg	1	2 kits
see page 09.03	Handle kit	2	1 kit
234410 234416	Handle kit	3	1 kit
225496	Handle fastening kit	4	1 kit
see page 09.01	Handle transmission	5	1 kit
see page 09.06		6	1 kit
see page 09.01	Connecting rod	7	2 pcs
227680	Packers 21 mm	8	3 kits
see page 09.04	Stop	9	4 kits
see page 09.01	Hook	10	2 pcs
see page 09.01	Locking bolt (night vent)	11	1 pc
188636	Fastening kit	12	4 kits
209738	Espag extension	13	1 kit

Article	Name	Position	1..
Hardware			
see page 09.05	Microlift >200 kg	14	2 kits
see page 09.03	Cylinder	15	1 kit
189628	Roller fastening kit	16, 17, 18	5 kits



Handle transmission fitting recommendations:
Gr240: 2786mm < Hcs < 3085mm (with 209738)
Gr270: 3086mm < Hcs < 3385mm (with 209738)

Example of hardware fitting for lift and slide sashes

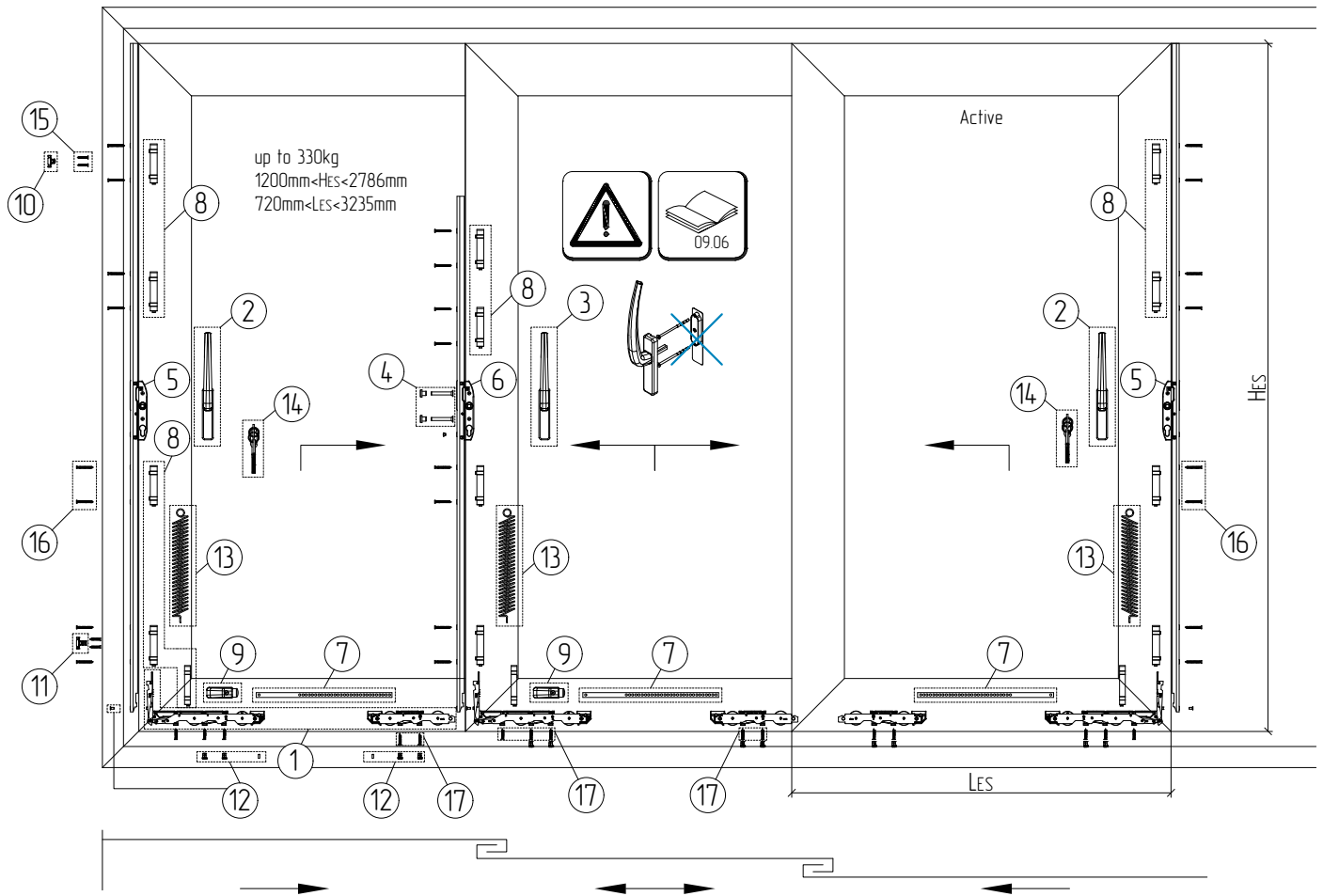

Article	Name	Position	1..
Hardware			
302311	Bogie kit 330 kg	1	6 kits
see page 09.03	Handle kit	2	4 kits
234410	Handle kit	3	2 kits
225496	Handle fastening kit	4	2 kits
see page 09.01	Handle transmission	5	3 kits
see page 09.06		6	3 kits
see page 09.01	Connecting rod	7	6 pcs
227680	Packers 21 mm	8	6 kits
see page 09.04	Stop	9	4 kits
see page 09.01	Hook	10	3 pcs
see page 09.01	Locking bolt (night vent)	11	3 pcs
188636	Fastening kit	12	6 kits
see page 09.05	Microlift	13	6 kits
see page 09.03	Cylinder	14	4 kits
189628	Roller fastening kit	15, 16, 17	6 kits

Example of hardware fitting for lift and slide sashes

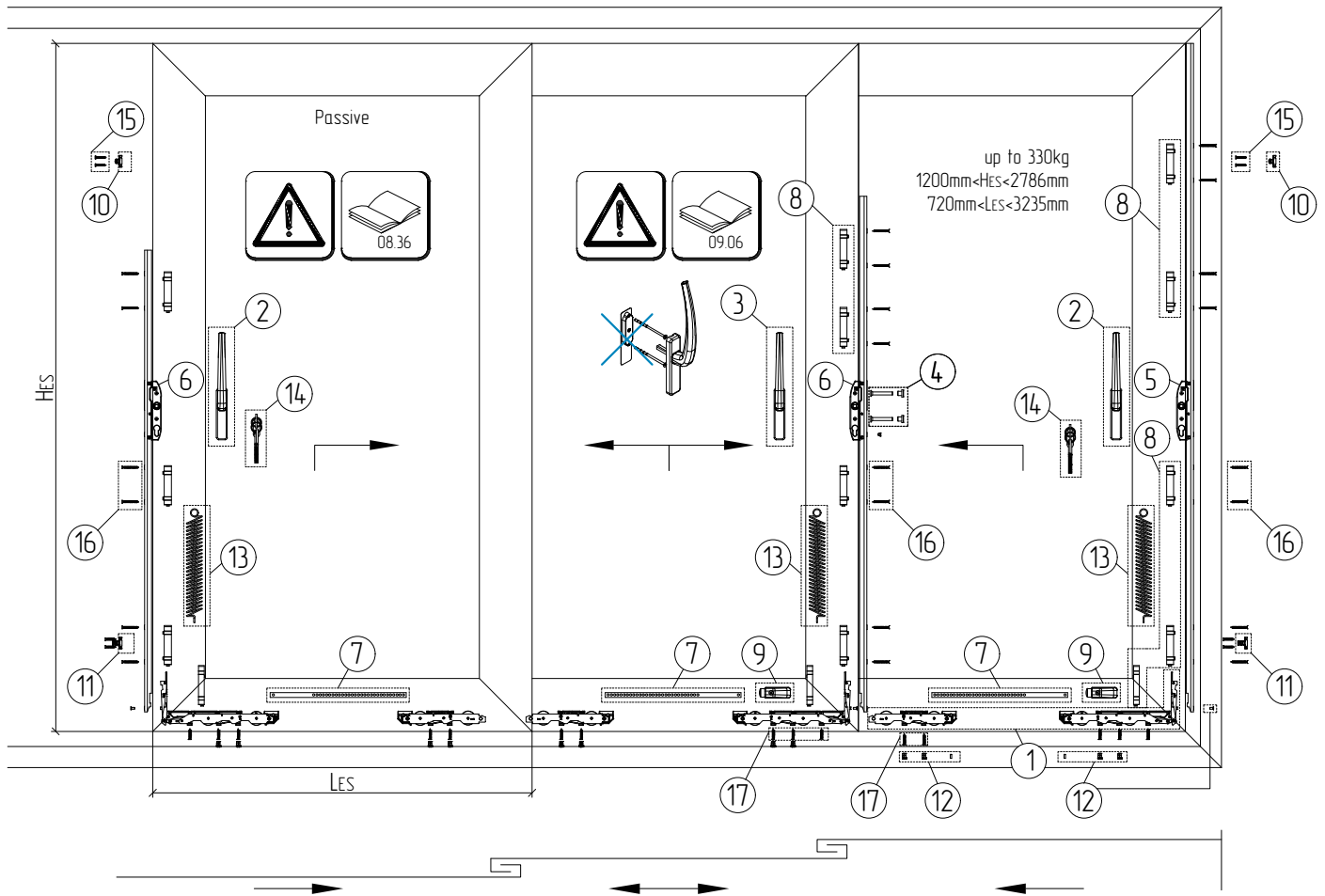

Example of hardware fitting for lift and slide sashes

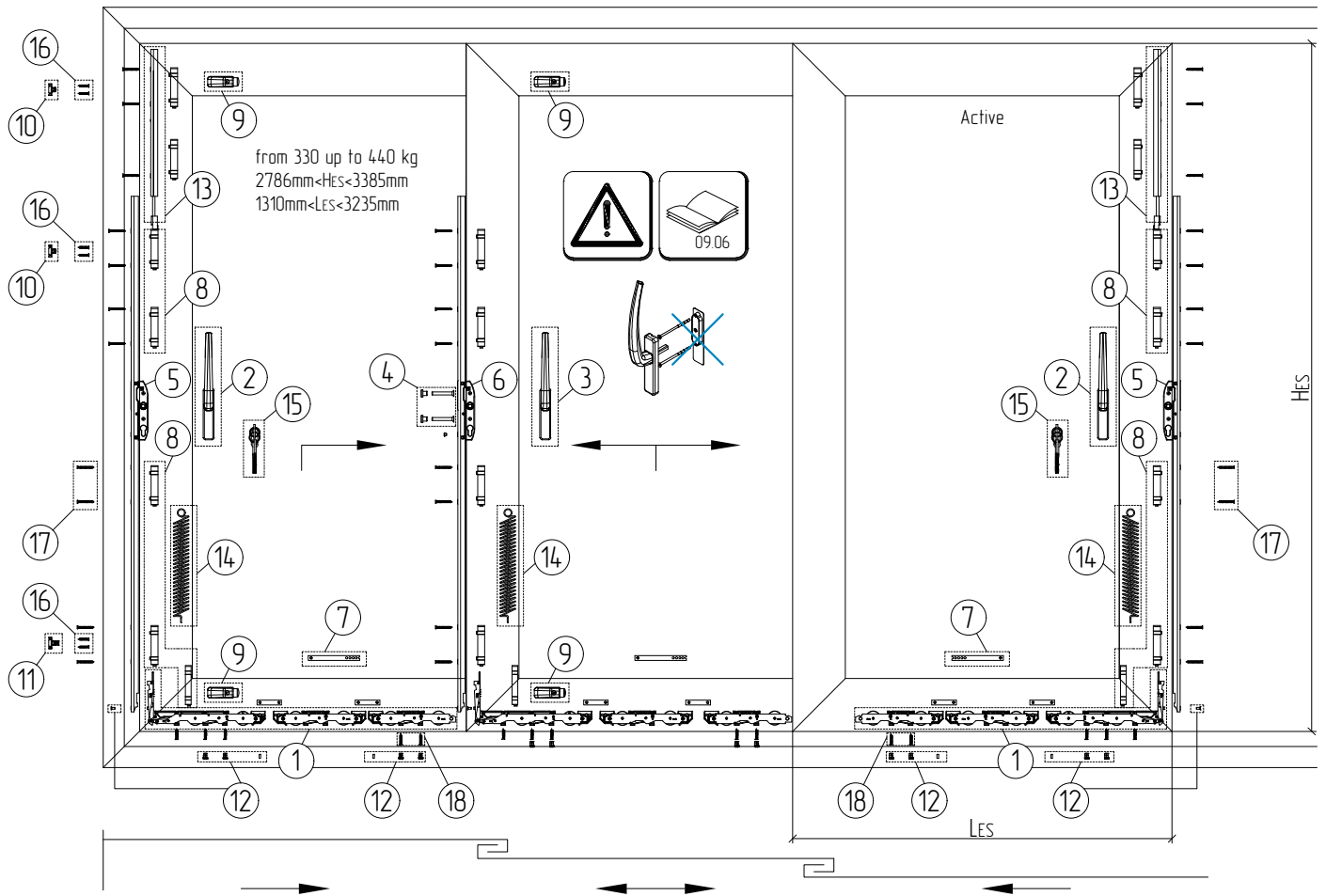

Article	Name	Position	1..
Hardware			
302311	Bogie kit 330 kg	1	6 kits
302326	Tandem bogie 440 kg	1	6 kits
see page 09.03	Handle kit	2	4 kits
234410	Handle kit	3	2 kits
225496	Handle fastening kit	4	2 kits
see page 09.01	Handle transmission	5	3 kits
see page 09.06		6	3 kits
see page 09.01	Connecting rod	7	6 pcs
227680	Packers 21 mm	8	9 kits
see page 09.04	Stop	9	8 kits
see page 09.01	Hook	10	6 pcs
see page 09.01	Locking bolt (night vent)	11	3 pcs
188636	Fastening kit	12	12 kits
209738	Espag extension	13	3 kits

Article	Name	Position	1..
Hardware			
see page 09.05	Microlift >200 kg	14	6 kits
see page 09.03	Cylinder	15	4 kits
189628	Roller fastening kit	16, 17, 18	15 kits



Handle transmission fitting recommendations:
Gr240: 2786mm<Hes<3085mm (with 209738)
Gr270: 3086mm<Hes<3385mm (with 209738)

Example of hardware fitting for lift and slide sashes

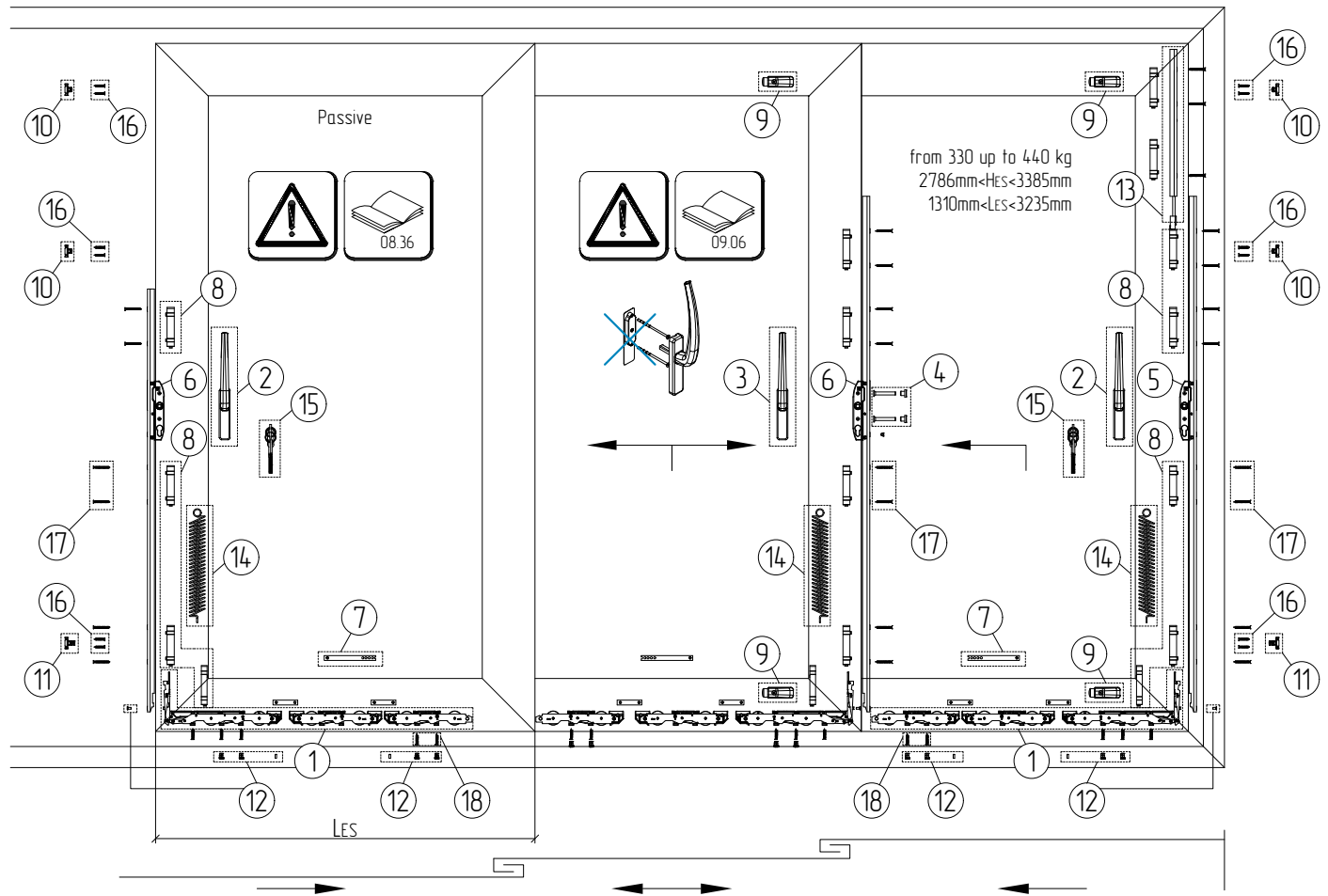

01

02

03

04

05

06

07

08

09

10

Example of hardware fitting for lift and slide sashes

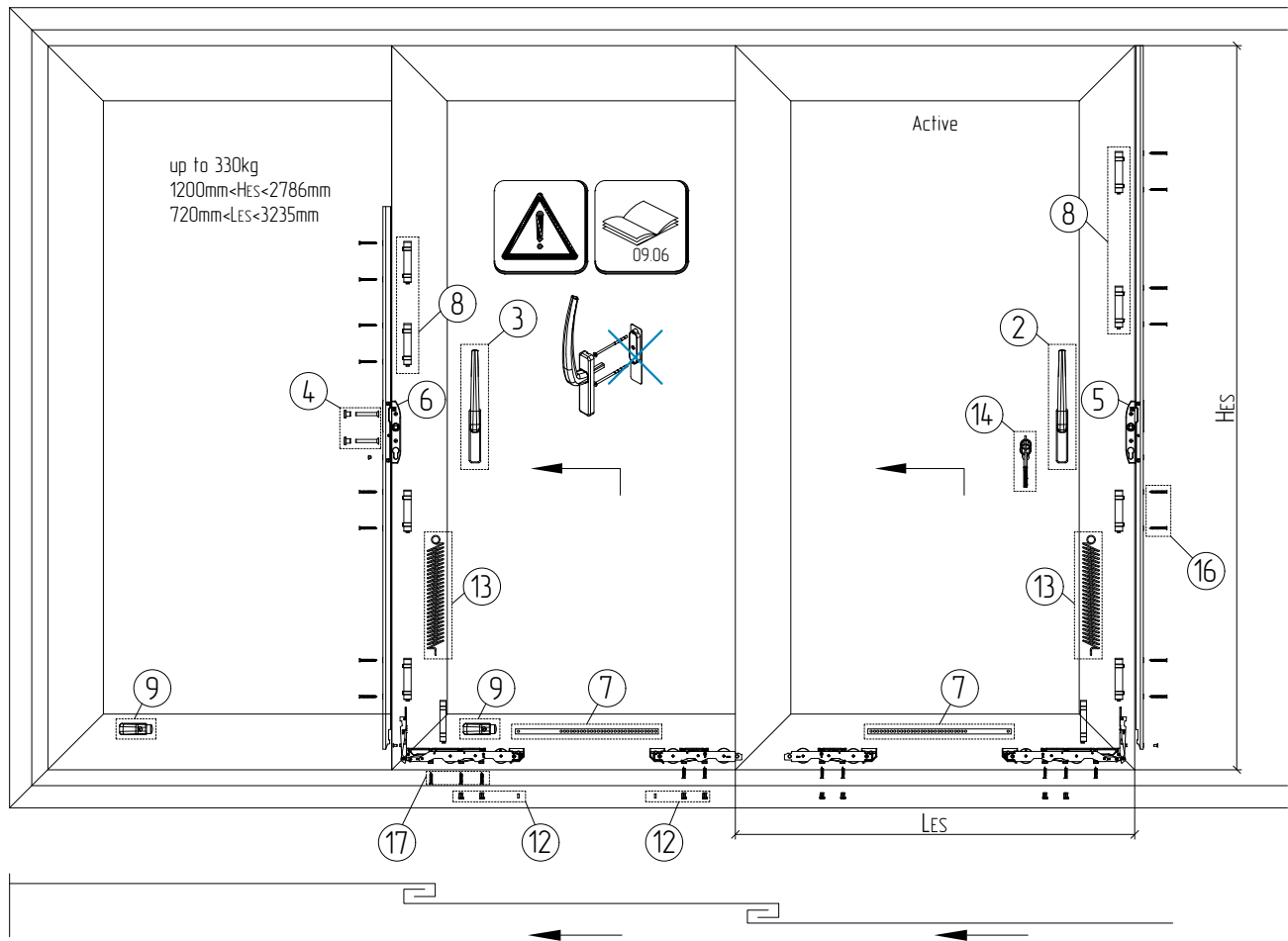

Article	Name	Position	1..
Hardware			
302311	Bogie kit 330 kg	1	4 kits
see page 09.03	Handle kit	2	2 kits
234410	Handle kit	3	2 kits
225496	Handle fastening kit	4	2 kits
see page 09.01	Handle transmission	5	1 kit
see page 09.06		6	3 kits
see page 09.01	Connecting rod	7	4 pcs
227680	Packers 21 mm	8	4 kits
see page 09.04	Stop	9	4 kits
190327	Locking bolt	10	1 pc
190321	Locking bolt (night vent)	11	1 pc
188636	Fastening kit	12	4 kits
see page 09.05	Microlift	13	4 kits
see page 09.03	Cylinder	14	2 kits
189628	Roller fastening kit	15, 16, 17	4 kits

Example of hardware fitting for lift and slide sashes

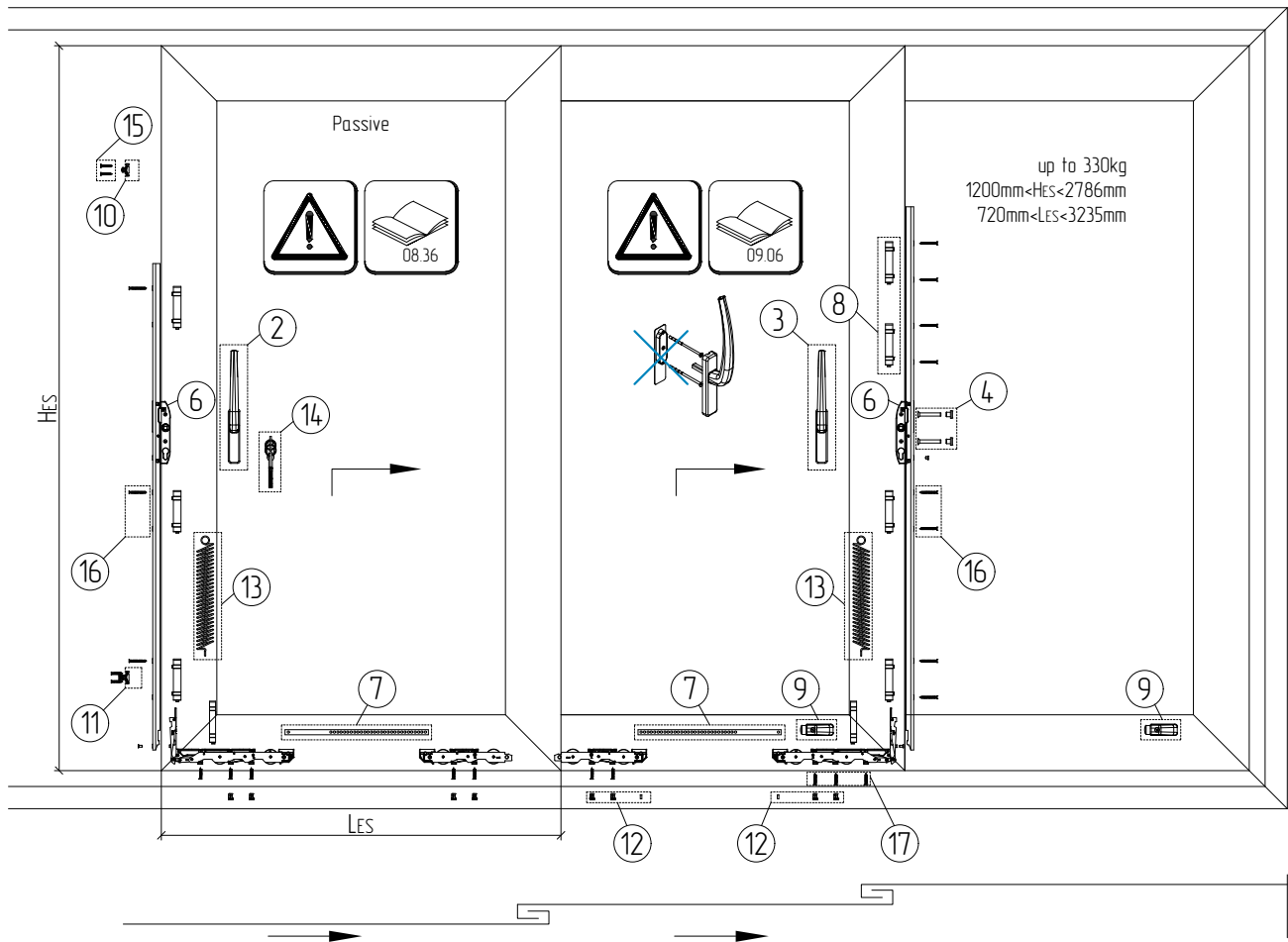

01

02

03

04

05

06

07

08

09

10

Example of hardware fitting for lift and slide sashes

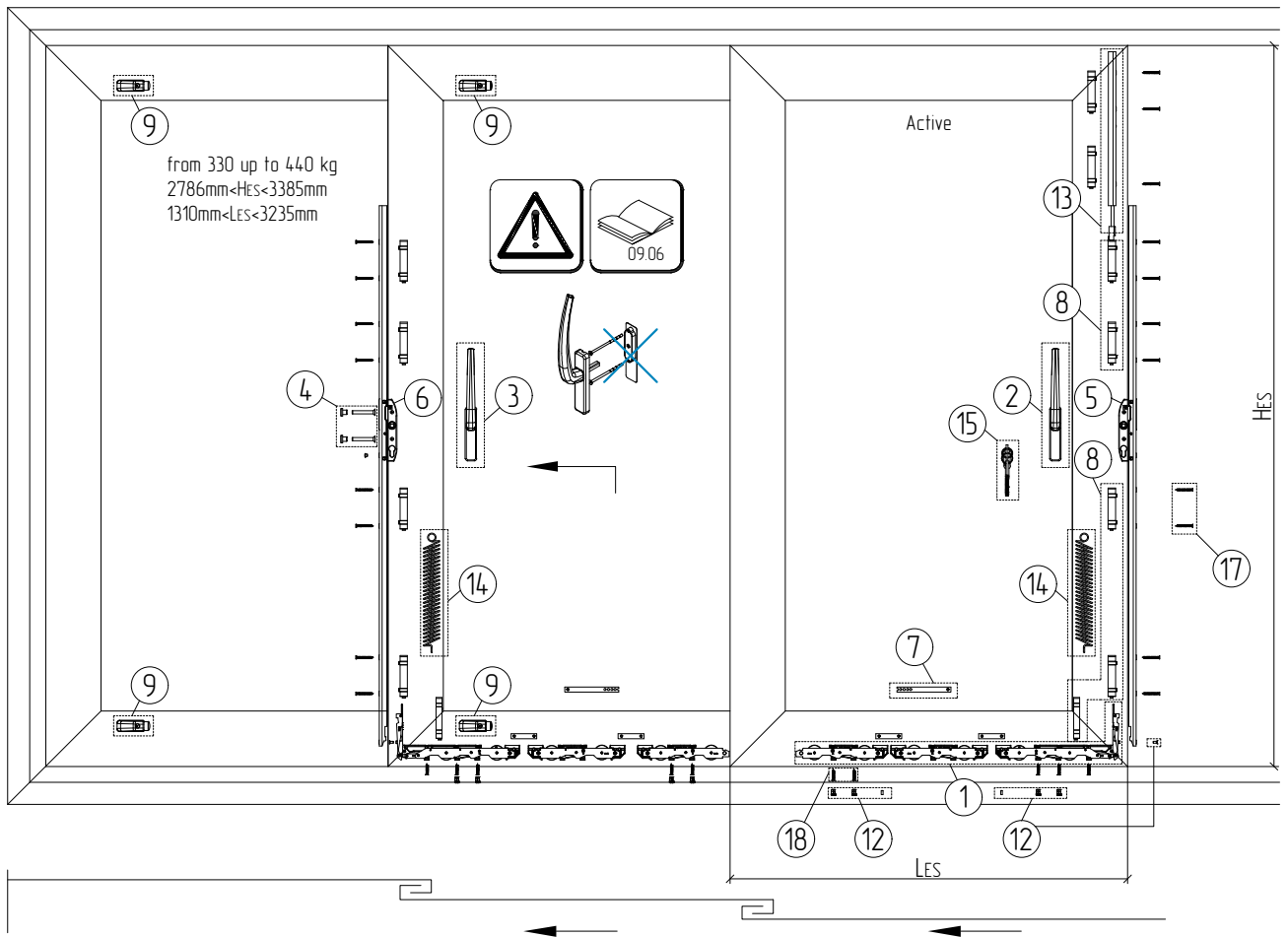

Article	Name	Position	1...
Hardware			
302311	Bogie kit 330 kg	1	4 kits
302326	Tandem bogie 440 kg	1	4 kits
see page 09.03	Handle kit	2	2 kits
234410	Handle kit	3	2 kits
225496	Handle fastening kit	4	2 kits
see page 09.01	Handle transmission	5	1 kit
see page 09.06		6	3 kits
see page 09.01	Connecting rod	7	4 pcs
227680	Packers 21 mm	8	5 kits
see page 09.04	Stop	9	8 kits
see page 09.01	Hook	10	2 pcs
see page 09.01	Locking bolt (night vent)	11	1 pcs
188636	Fastening kit	12	8 kits
209738	Espag extension	13	1 kit

Article	Name	Position	1...
Hardware			
see page 09.05	Microlift >200 kg	14	4 kits
see page 09.03	Cylinder	15	2 kits
189628	Roller fastening kit	16, 17, 18	9 kits



Handle transmission fitting recommendations:
Gr240: 2786mm<Hes<3085mm (with 209738)
Gr270: 3086mm<Hes<3385mm (with 209738)

Example of hardware fitting for lift and slide sashes

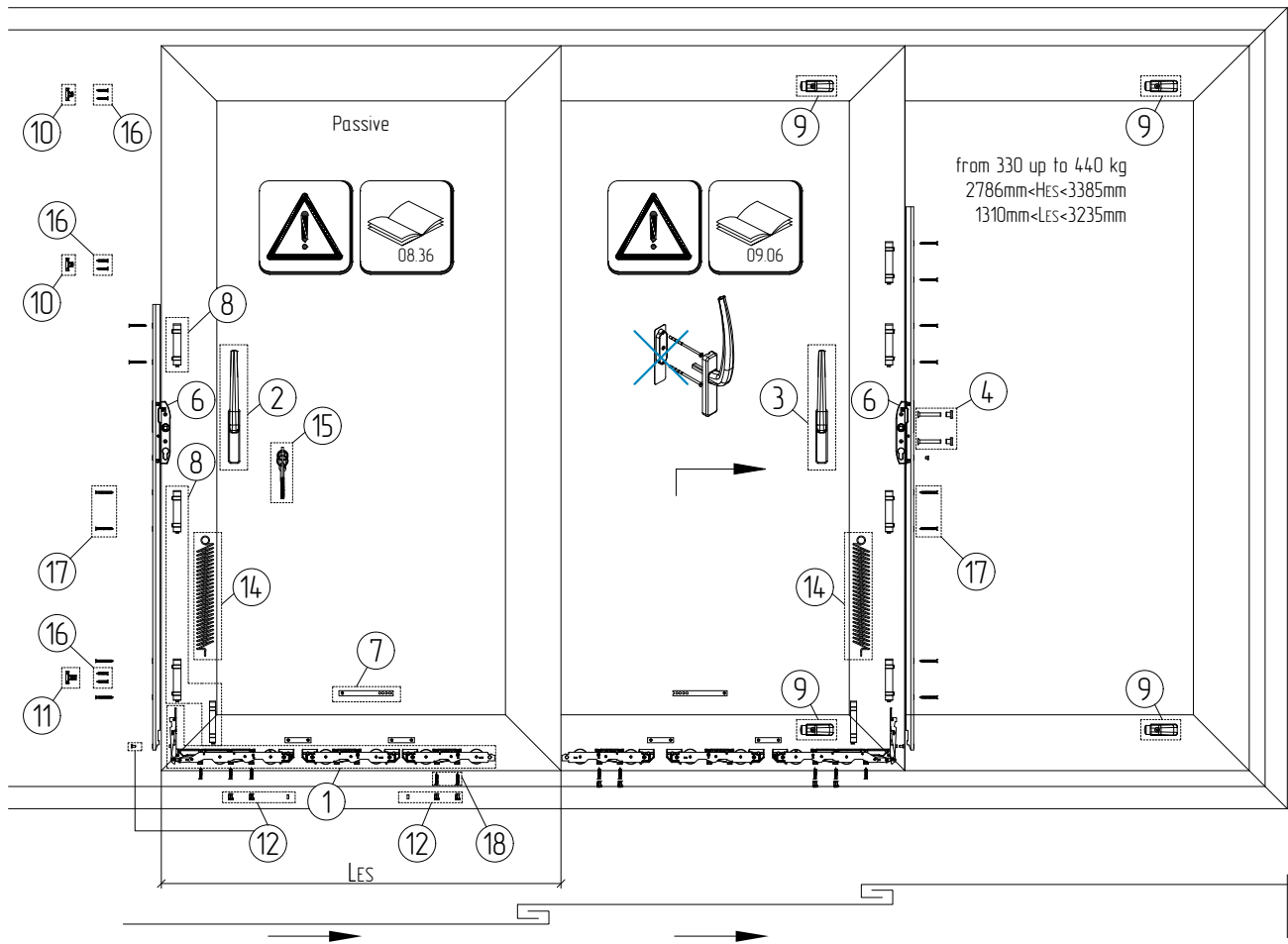

01

02

03

04

05

06

07

08

09

10

Example of hardware fitting for lift and slide sashes

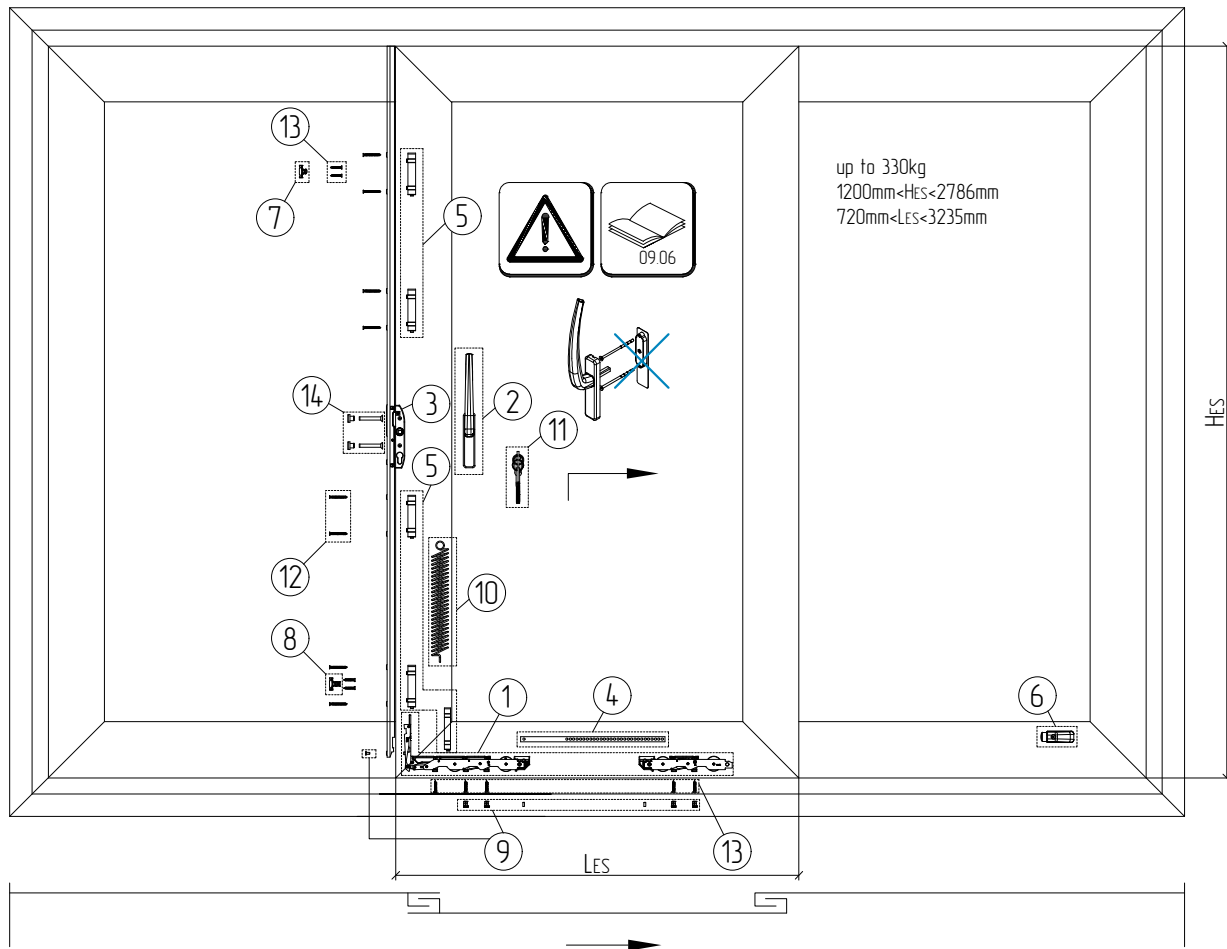

Article	Name	Position	1..
Hardware			
302311	Bogie kit 330 kg	1	1 kit
see page 09.03	Handle kit	2	1 kit
see page 09.01	Handle transmission	3	1 kit
see page 09.01	Connecting rod	4	1 pc
227680	Packers 21 mm	5	1 kit
see page 09.04	Stop	6	1 kit
see page 09.01	Hook	7	1 pc
see page 09.01	Locking bolt (night vent)	8	1 pc
188636	Fastening kit	9	1 kit
see page 09.05	Microlift	10	1 kit
5304.00	Cylinder	11	1 kit
189628	Roller fastening kit	12, 13	1 kit
225496	Handle fastening kit	14	1 kit

Example of hardware fitting for lift and slide sashes

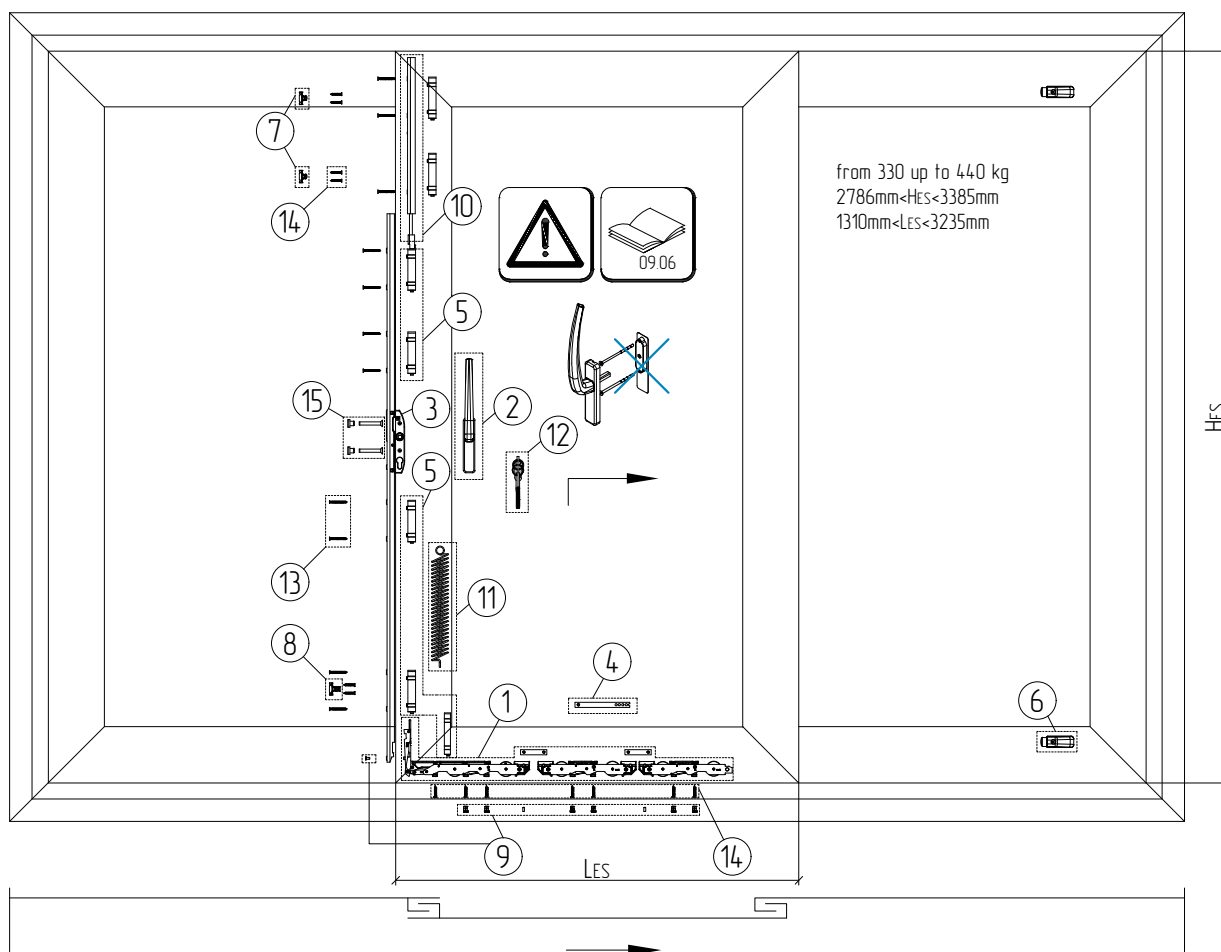

Article	Name	Position	1..
Hardware			
302311	Bogie kit 330 kg	1	1 kit
302326	Tandem bogie 440 kg	1	1 kit
see page 09.03	Handle kit	2	1 kit
see page 09.01	Handle transmission	3	1 kit
see page 09.01	Connecting rod	4	1 pc
227680	Packers 21 mm	5	2 kits
see page 09.04	Stop	6	2 kits
see page 09.01	Hook	7	2 pcs
see page 09.01	Locking bolt (night vent)	8	1 pc
188636	Fastening kit	9	2 kits
209738	Espag extension	10	1 kit
see page 09.05	Microlift >200 kg	11	1 kit
5304.00	Cylinder	12	1 kit
189628	Roller fastening kit	13, 14	3 kits

Article	Name	Position	1..
Hardware			
225496	Handle fastening kit	15	1 kit



Handle transmission fitting recommendations:
Gr240: 2786mm<Hes<3085mm (with 209738)
Gr270: 3086mm<Hes<3385mm (with 209738)



ALUTECH ALT SL160

Lifting and sliding constructions

01

02

03

04

05

06

07

08

09

10

STATICS

Geometrical characteristics of profiles

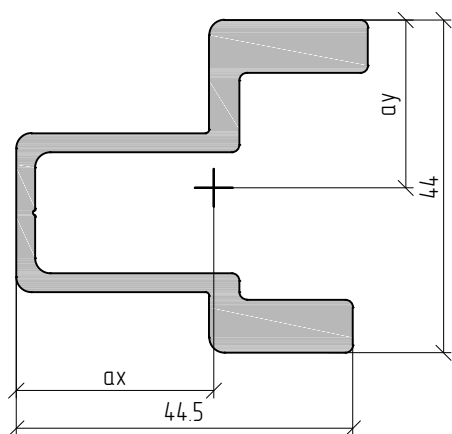
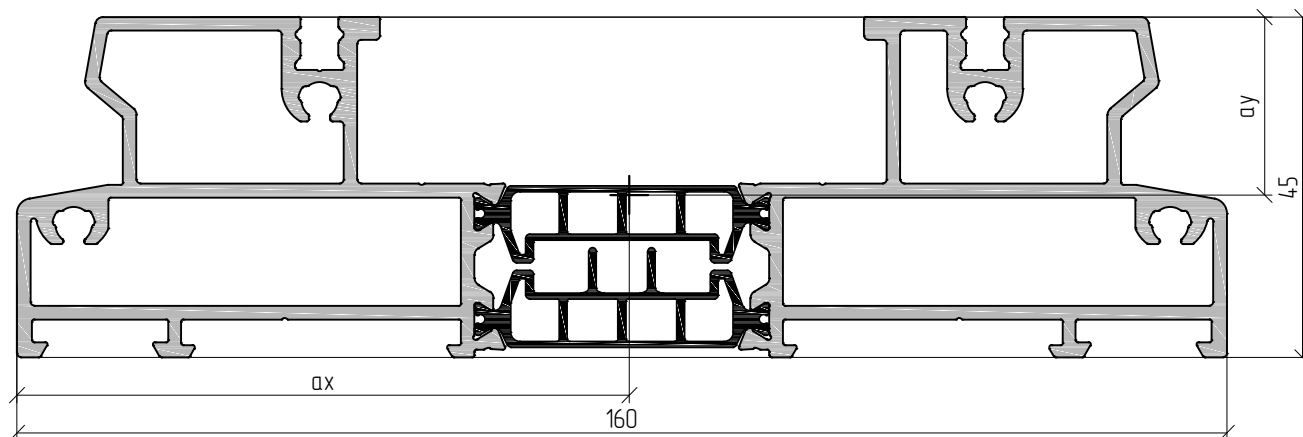
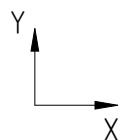

AYPC.SL160.0701

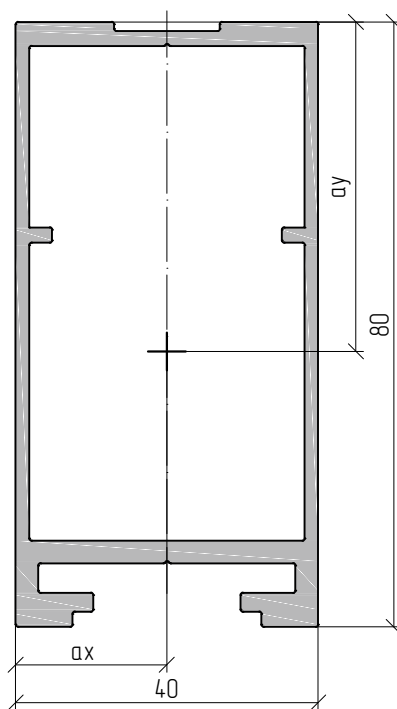

AYPC.SL160.0702

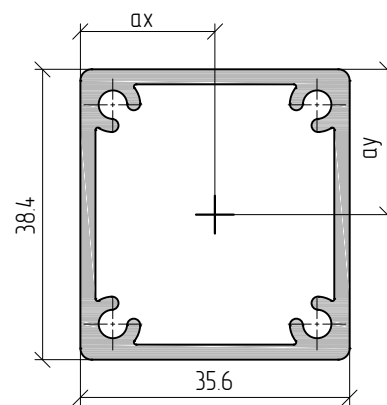

AYPC.C43.0706

Profile	m, kg/m	S, mm ²	Jx, cm ⁴	Wx, cm ³	ax, mm	Jy, cm ⁴	Wy, cm ³	ay, mm
AYPC.SL160.0101	3.34	1347.3	216	9.2	81.0	233.0	28.8	23.5
AYPC.SL160.0102	3.27	1336.6	17.8	5.8	73.8	197.4	26.7	30.8
AYPC.SL160.0103	3.32	1355.2	18.4	6.0	87.1	201.0	23.1	30.5
AYPC.SL160.0104	4.68	1952.5	30.2	12.7	125.2	765.1	61.1	23.7
AYPC.SL160.0701	1.35	500.9	11.7	5.3	26.1	8.8	3.4	22.2
AYPC.SL160.0702	1.57	583.0	49.5	11.4	20.0	15.0	7.5	43.6
AYPC.C43.0706	0.92	342.2	7.4	3.9	17.8	6.5	3.7	19.2

Geometrical characteristics of profiles

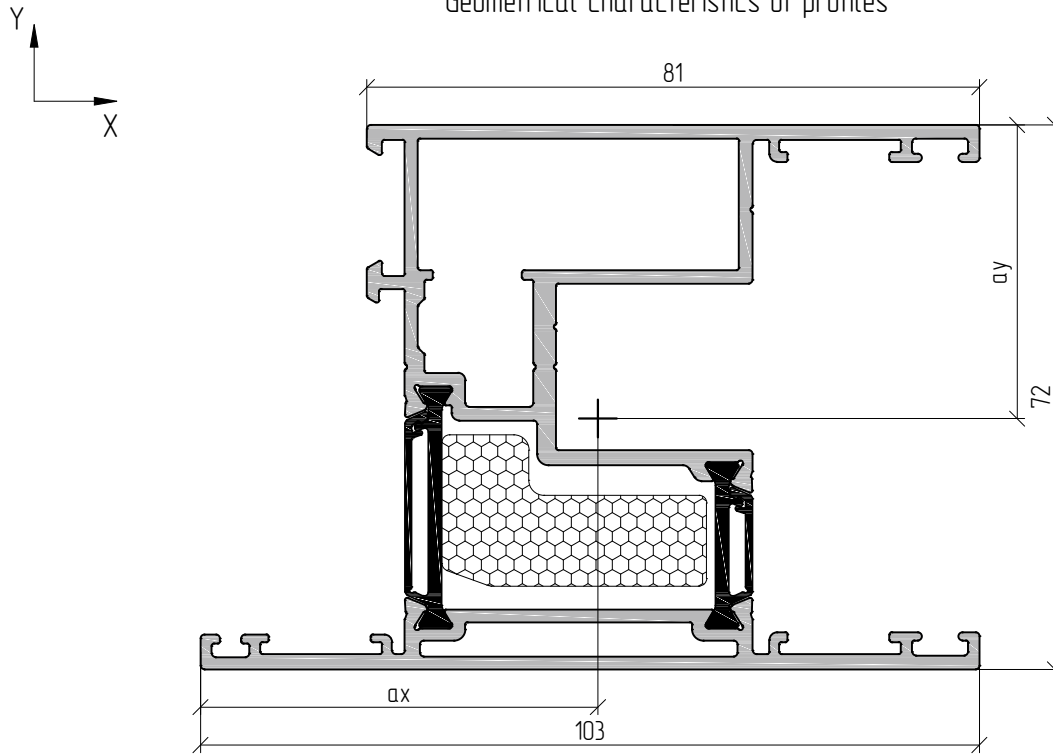

AYPC.SL160.0202 + AYPC.SL160.0701

AYPC.SL160.0202 + AYPC.SL160.0702

AYPC.SL160.0202 + AYPC.SL160.0701 +
AYPC.SL160.0702

AYPC.SL160.0202 + AYPC.SL160.0701 +
AYPC.SL160.0702 + AYPC.C43.0706

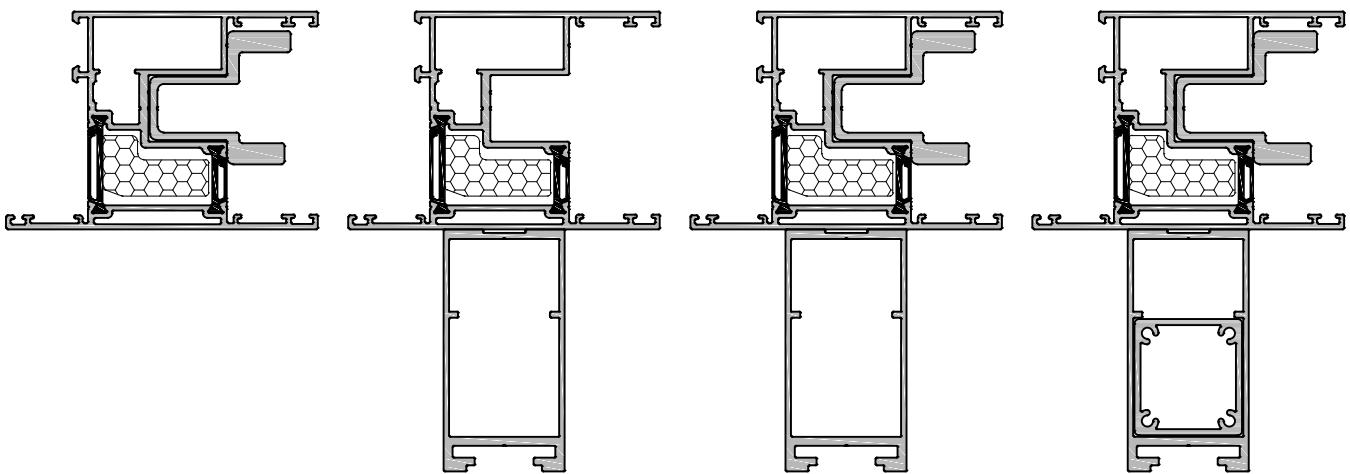

Profile	m, kg/m	S, mm ²	Jx, cm ⁴	Wx, cm ³	ax, mm	Jy, cm ⁴	Wy, cm ³	ax, mm
AYPC.SL160.0202	2.50	1003.6	48.0	12.4	52.6	48.6	9.2	38.8
AYPC.SL160.0202 + AYPC.SL160.0701	3.85	1504.5	56.8	16.3	-	57.4	12.6	-
AYPC.SL160.0202 + AYPC.SL160.0702	4.07	1586.6	237.5	45.6	81.8	63.7	7.8	52.1
AYPC.SL160.0202 + AYPC.SL160.0701 + AYPC.SL160.0702	5.42	2087.5	246.2	49.5	-	72.5	11.2	-
AYPC.SL160.0202 + AYPC.SL160.0701 + AYPC.SL160.0702 + AYPC.C43.0706	6.34	2429.7	297.3	41.0	-	70.2	16.9	-

Geometrical characteristics of profiles

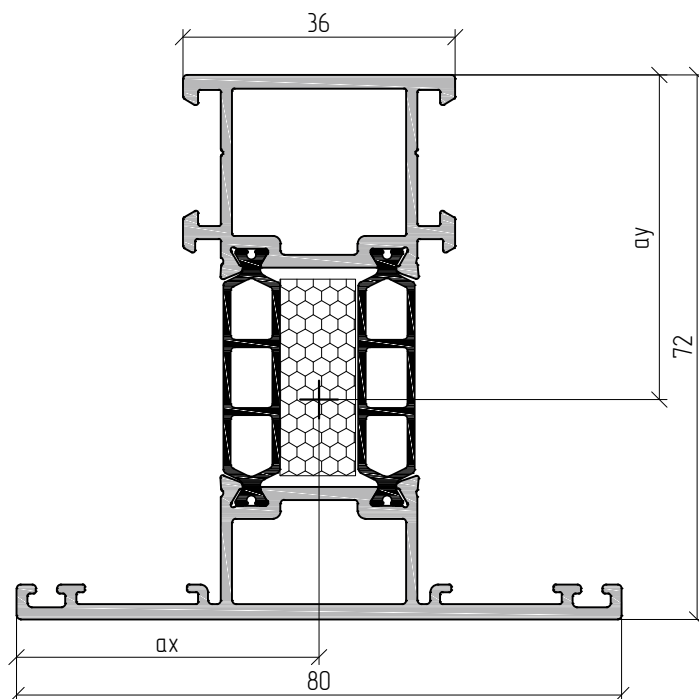
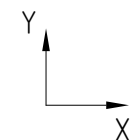

AYPC.SL160.0301 + AYPC.SL160.0702*

AYPC.SL160.0301 + AYPC.SL160.0702* +
AYPC.C43.0706

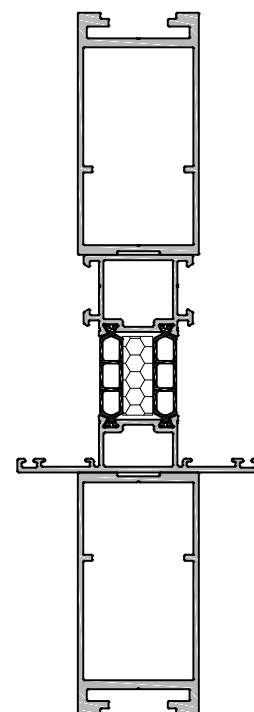
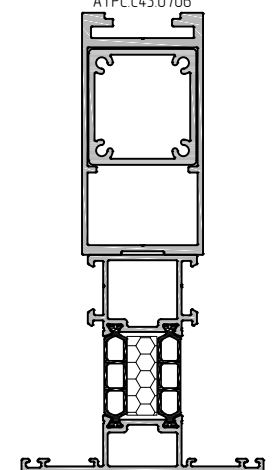
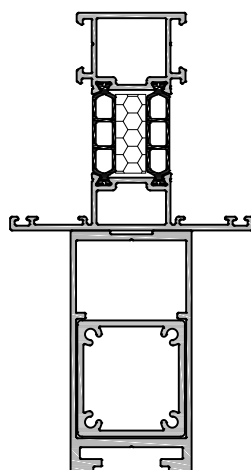
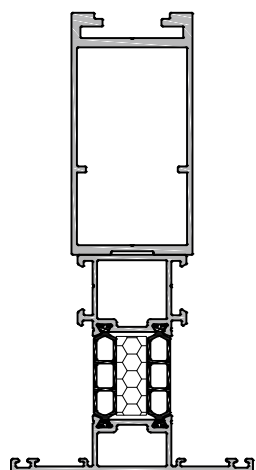
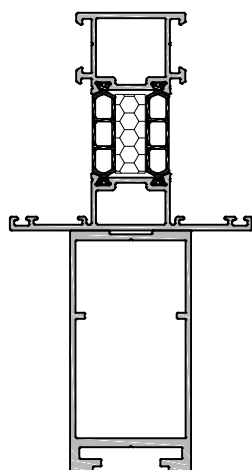

AYPC.SL160.0301 + AYPC.SL160.0702

AYPC.SL160.0301 + AYPC.SL160.0702 +
AYPC.C43.0706

AYPC.SL160.0301 + AYPC.SL160.0702**

Profile	m, kg/m	S, mm ²	Jx, cm ⁴	Wx, cm ³	ax, mm	Jy, cm ⁴	Wy, cm ³	ax, mm
AYPC.SL160.0301	1.66	703.5	30.0	7.0	40.0	15.2	3.8	42.9
AYPC.SL160.0301 + AYPC.SL160.0702	3.23	1286.5	176.1	44.0	40.0	30.2	3.7	81.3
AYPC.SL160.0301 + AYPC.SL160.0702*	3.23	1286.5	221.6	55.4	40.0	30.2	3.9	77.3
AYPC.SL160.0301 + AYPC.SL160.0702 + AYPC.C43.0706	4.15	1628.7	213.2	53.3	40.0	36.7	4.0	90.8
AYPC.SL160.0301 + AYPC.SL160.0702* + AYPC.C43.0706	4.15	1628.7	269.9	67.5	40.0	36.7	4.3	85.8
AYPC.SL160.0301 + AYPC.SL160.0702**	4.80	1869.5	659.3	164.8	40.0	45.2	3.8	118.1

Geometrical characteristics of profiles

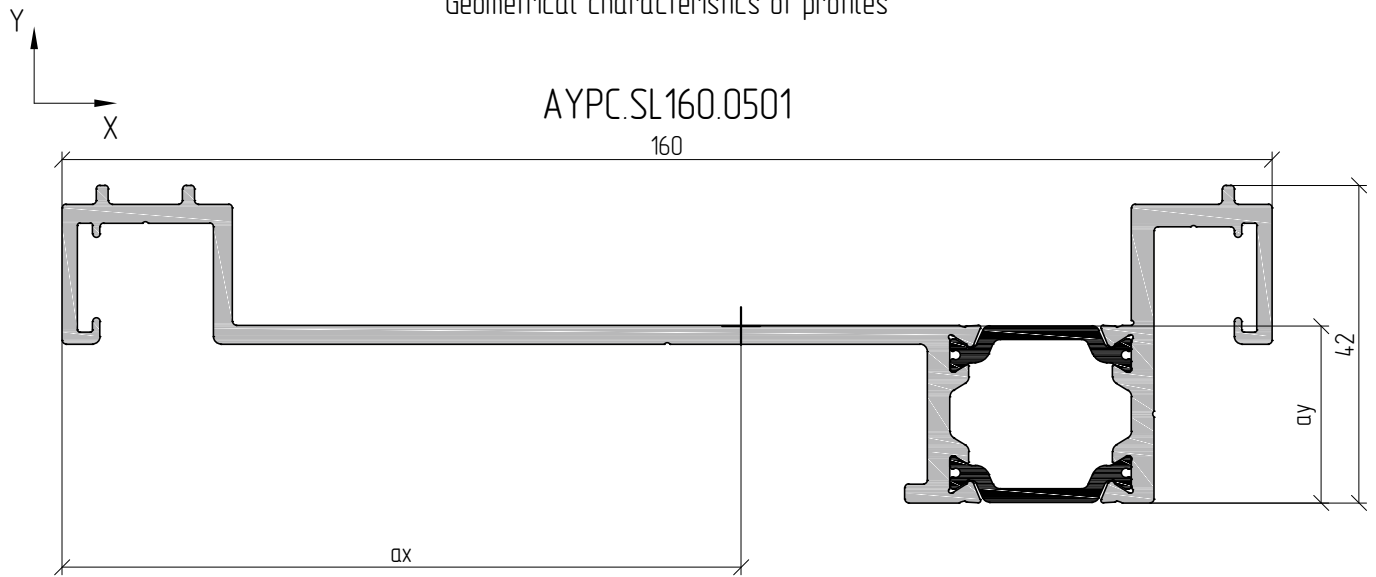

AYPC.SL160.0504

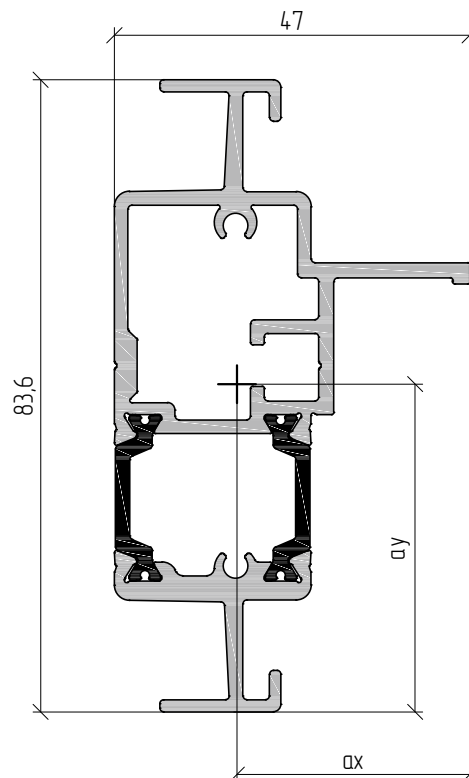

Profile	m, kg/m	S, mm ²	Jx, cm ⁴	Wx, cm ³	ax, mm	Jy, cm ⁴	Wy, cm ³	ay, mm
AYPC.SL160.0501	2.08	827.0	7.7	3.3	89.8	201.9	22.5	23.4
AYPC.SL160.0504	1.59	639.2	30.2	9.8	30.8	5.8	1.3	43.3

Geometrical characteristics of profiles

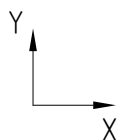

AYPC.SL160.0505

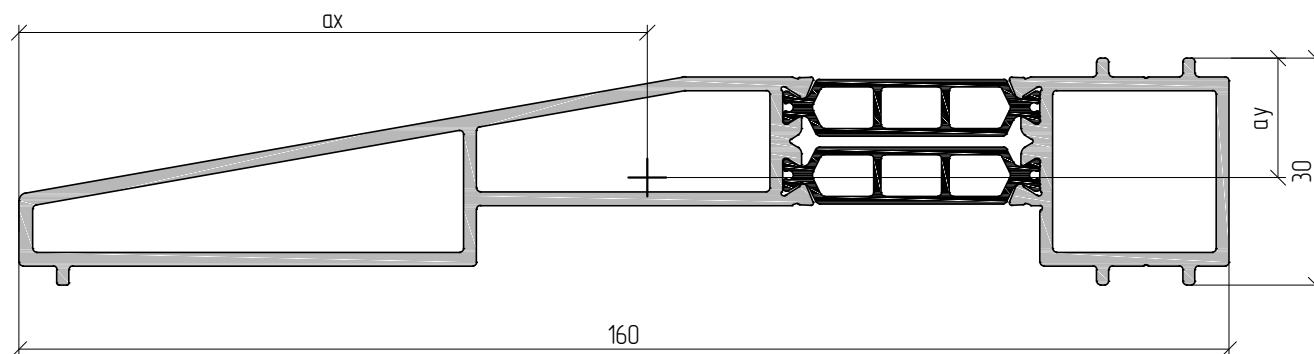

AYPC.SL160.0813

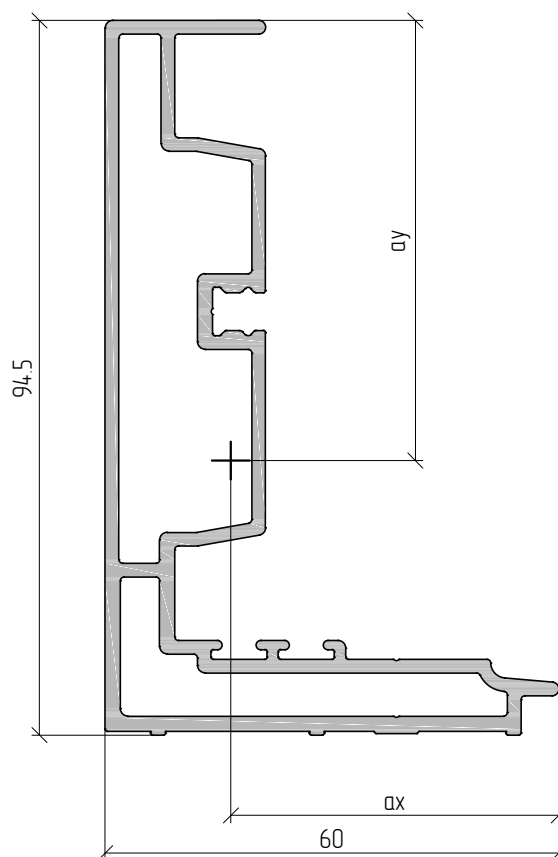

Profile	m, kg/m	S, mm ²	Jx, cm ⁴	Wx, cm ³	ax, mm	Jy, cm ⁴	Wy, cm ³	ay, mm
AYPC.SL160.0505	2.05	846.2	4.8	0.6	83.1	165.7	104.9	15.8
AYPC.SL160.0813	1.80	668.1	65.4	15.1	43.4	15.6	2.7	58.2

